

ASSESSING EXTREME WEATHER - RELATED VULNERABILITY AND IDENTIFYING RESILIENCE OPTIONS FOR CALIFORNIA'S INTERDEPENDENT TRANSPORTATION FUEL SECTOR

A Report for:

California's Fourth Climate Change Assessment

Prepared By:

Primary Authors:

John D. Radke
Greg S. Biging
Karlene Roberts

Co-Authors:

M. Schmidt-Poolman, H. Foster, E. Roe, Y. Ju, S. Lindbergh, T. Beach, L. Maier, Y. He,
M. Ashenfarb, P. Norton, M. Wray, A. Alruheili, S. Yi, R. Rau, J. Collins, M. Coufal, D.
Radke, S. Marx, A. Gohar, D. Moanga, V. Ulyashin, A. Dalal.

University of California, Berkeley
Center for Catastrophic Risk Management.
820 Barrows Hall
Berkeley, CA 94720-1922
Phone: 510-643-5995

DISCLAIMER

This report was prepared as the result of work sponsored by the California Energy Commission. It does not necessarily represent the views of the Energy Commission, its employees or the State of California. The Energy Commission, the State of California, its employees, contractors and subcontractors make no warrant, express or implied, and assume no legal liability for the information in this report; nor does any party represent that the uses of this information will not infringe upon privately owned rights. This report has not been approved or disapproved by the California Energy Commission nor has the California Energy Commission passed upon the accuracy or adequacy of the information in this report.



Edmund G. Brown, Jr., *Governor*

August 2018
CCCA4-CEC-2018-012

ACKNOWLEDGEMENTS

This work was funded by the Petroleum Violation Escrow Account through the California Energy Commission (PVEA), grant FED-15-001 to the University of California, Berkeley. We gratefully acknowledge Dr. Susan Wilhelm, our project manager at the California Energy Commission, for her guidance, patience and expertise during the execution of this research. We are also grateful for the support, guidance and contacts provided by Guido Franco (Team Lead for Environmental Area Research, California Energy Commission) which served to enhance the quality of our research. Any mistake in this research document is the responsibility of the authors alone.

We are pleased to acknowledge the many private-sector representatives from the California Transportation Fuel Sector (TFS) and the many public-sector officials who attended our four workshops and engaged in our stakeholder discussions.

We would like to thank Daniel Stevens (CEM, Senior Manager, Accenture Consulting, formerly with Southern California Edison) for his input and hosting our first workshop at Southern California Edison, in Irwindale, CA. We would also like to thank F. Scott Humphrey (Training Director, Coast Guard Sector San Francisco Vessel Traffic Service) for his input and hosting our second workshop and for arranging ride-a-longs for our flood modeling team with three Coast Guard stations in Northern California. We also thank the Coast Guard Stations and personnel who took our flood modeling team on the ride-a-longs including: Coast Guard Station Rio Vista (BM1 Christopher A. Patton, BM2 Eberlee Santander, MK3 William Preston and SN Miguel Herrera), Coast Guard Station San Francisco (BM1 Wil Wiggins, BM2 Michael Scarbrough, FN Michel Plazas, SN Alejandro Miret and SN Megan Storey), and Coast Guard Station Vallejo (BM1 Trystan Domholt, MK3 Mason Lomeli, BM3 Lachaddrick Ellis and BM2 Drew Dunham). We thank Commander Jennifer Stockwell (U.S. Coast Guard) for providing us the opportunity to present our findings at the Coast Guard and at the Harbor Safety Committee of the San Francisco Bay Region, together with Captain Lynn Korwatch (Executive Director, Marine Exchange of the SF Bay Region). We would like to thank Bruce Edwards, NSWC and Leroy Barnhill, Terminal Supervisor at R&R (both in Crane, IN) for their early logistics support toward our coastal ground truth.

We are very pleased to acknowledge and thank the staff and personnel in Kinder Morgan Inc., who provided us with a great deal of their time and expertise under an NDA: Jerry Coronado (Manager, Control Center); Matt Dexter (Manager, Pipeline Maintenance); Darrell Donaho (GIS-PODS Manager, Pipeline Integrity); Robyn Lopez (Manager, Logistics Services); Scott Manley (Director of Operations, Pacific Northern Region); Nicole Stewart (Area Manager, Area Manager - Brisbane Terminal & Richmond Station); Johnny Thomasson (Director - Product Movement); and others at the Orange Control Center.

We would like to give special thanks to Lieutenant Colonel Justin Settles (Commanding Officer, Defense Logistics Agency-Energy Americas West Region), Paul King (Former Deputy Director, CPUC) and Gordon Schremp (Senior Fuels Specialist, California Energy Commission) who generously offered their vital support to this project by helping us understand the Transportation Fuel Sector in the context of extreme weather-related events.

We are grateful to Miles Heller (Director of West Coast Fuels and Regulatory Affairs), Tim Fitzpatrick (Staff Engineer) and Robert Kestenbaum (Lead Contingency Planning Specialist) of Andeavor, Mark Sandon (Vice President of Operations) and Mike Romley (Director of Operations of West Coast) of Crimson Pipeline, Tom Jacobsen (President, CEO) and Mark Coynes (Pilot) of Jacobsen Pilot Services, Larry Mares (Manager of Emergency Operations and Planning) and Jessica Feil (Emergency Management Coordinator) at SFO, Ryan Hanretty (Executive Director, CIOMA), Brent Andrews (President, Interstate Oil), Dominic Ferrari (Vice President of West Coast Pipelines, Plains All American), Mike Downs (President, Downs Energy), Miki Crowell (Air Pollution Specialist, California Energy Commission), and finally, the Crude Oil Reconnaissance Team (CORT) of CPUC: Matthew Cardiff (Senior Transportation Operations Supervisor), Edward Chavez (Rail Operations and Safety Supervisor), James Rand (Hazardous Materials Inspector), and Tom Hervey (Former Associate Transportation Operations Supervisor). We would like to thank Brian Madden (Lt. Cmdr. Fuel Officer, US Navy, NAVSUP Fleet Logistics Center San Diego), Robert Slatt (Fuels Operation Section Chief, Travis Air Force), Jeff Wiese (Vice President and National Practice Leader for Pipeline Integrity Services at TRC Solutions, formerly at PHMSA), Malone (Public Affairs Specialist, California Fuel Cell Partnership), Babul Patel (Principal, Nexant Inc.), DeLisa Leighton (Director of Hydrogen Services, IGX-Group), John Cornish (President, EPC), Patrick Fiedler (President, Fiedler Group), Jonathan Avila (CEO, Stratos Fuel) and Brent Koski (Chief Operating Officer, United Hydrogen). All of these representatives provided invaluable insight on the TFS through our stakeholder discussions. We would like to thank Jill Raycroft (Lead Exercise Coordinator, SF Department of Emergency Management) for our multiple discussions and for integrating our project into the SF 2018 Fleet Week Fuel Round Robin Exercise.

We would also like to acknowledge the Google Earth Engine team and the Geo for Good program who provided us credits to use the Google Cloud Platform that significantly increased our flood and fire modeling capacity. Especially, Nick Clinton (Google Earth Engine Team) who offered technical support, Allie Lieber (Google Earth Outreach Team) who administered the cloud credits, and Rebecca Moore (Director of Google Geo for Good).

We are grateful to Yiguo Liang (Department of Water Resources) and Albert Kettne (Research Associate at University of Colorado and Co-Director, Dartmouth Flood Observatory) who provided us with historical flooding data. We would also like to acknowledge Steven Chang (Senior Civil Engineering Technician, Los Angeles County Public Works) for providing rainfall data and Arthur Gotingco (Principle Civil Engineering Technician, Los Angeles County Public Works) for providing discharge data. Lastly, we would like to thank Jaeung Yi (Visiting Scholar, Ajou University) for advising on hydrologic modeling.

At the initiation of this project Dr. Weise (USFS Riverside Fire Lab) provided advice that helped us formulate a fire modeling approach and the resolution at which we should model when examining fire risk at or near TFS infrastructure. This led us to work with Dr. Mark Finney (Research Forester, Missoula Fire Science Lab, USFS) whose FlamMap software is used for landscape fire behavior assessment and fuel treatment optimization. FlamMap was instrumental in producing our wildfire hazard estimates. Dr. Finney's input on constructing our wildfire model as accurately as possible, while maintaining high-resolution precision, was invaluable. We appreciate the work and contributions from Ben Sleeter (Supervisory Research Geographer, USGS) who provided us with insights from and early access to newer, higher-resolution regional wildfire futures. We would also like to acknowledge Eric Rice (Fire

Suppression Manager and Tahoe Hotshots Superintendent, Yuba River Ranger District, USFS) and Jason Powers (Fuel Manager and Forestry Technician, Yuba River Ranger District, USFS) for their thoughtful input on vegetation fuel model selection and feedback on the fidelity of our wildfire behavior metrics. We are thankful for the support and insight provided by the CAL FIRE - FRAP group, specifically Tadashi Moody (Environmental Scientist) for the CAL FIRE data, and David Sapsis and Mark Rosenberg (Research Program Specialists) for their open discussions on fuels.

We appreciate the data shared by Vince Ambrosia (Associate Program Manager, NASA Applied Science Wildfire Program) and Jan Johnson (Remote Sensing Specialist, Geospatial Technology and Applications Center, USFS). The thermal infrared data recorded during the Tubbs Fire was essential to validate our high-resolution model; without their cooperation, such a validation would have been impossible. We appreciate the efforts of Mark Tukman (Tukman Geospatial) for facilitating the Sonoma County Open Data Initiative following the Tubbs Fire, and for his assistance in helping us interpret the Soil Burn Severity dataset. We are thankful to Leo Liu of GreenValley International LiDAR, whose efforts and resources allowed us to capture data and model wildfire behavior in regions otherwise impossible to model. We appreciate the time of the PG&E Gas Operations staff, especially that of Teddy Atkinson (Gas Technical Specialist), and for their feedback on the feasibility of incorporating the models developed on this project to existing utilities risk management models. For assistance and support in preparation and execution of our initial workshops we would like to thank the Scaling Group.

We are grateful to the members of our Technical Advisory Committee (TAC) who individually supported us in identifying key stakeholders and provided us with insight into the TFS: Gordon Schremp (Senior Fuels Specialist, California Energy Commission) who served as the Chair of the TAC, Mike Downs (President, Downs Energy), Tom Ducker (CIP Team Lead, Cal OES), Dominic Ferrari (Vice President of West Coast Pipelines, Plains All American), Ryan Hanretty (Executive Director, CIOMA), Miles Heller (Director of West Coast Fuels and Regulatory Affairs, Andeavor), Ken Hudnut (Science Advisor, USGS), Paul King (Former Deputy Director, CPUC), Alice Lippert (retired Technical Advisor, US DoE), Leslie Luke (Deputy Director, County of LA, OEM), Larry Mares (Manager of Emergency Operations and Planning, SFO), Phil Oglesby (Senior Analyst, San Diego Law Enforcement Coordination Center), Mark Sandon (Vice President of Operations, Crimson Pipeline), Lieutenant Colonel Justin Settles (Commanding Officer, Defense Logistics Agency-Energy Americas West Region), Daniel Stevens (CEM, Senior Manager, Accenture Consulting, formerly with Southern California Edison), Rod Wheeler (Operations Policy Lead, Cal ISO) and Jim Wollbrinck (Manager of Security and business Resiliency, San Jose Water Company).

PREFACE

California's Climate Change Assessments provide a scientific foundation for understanding climate-related vulnerability at the local scale and informing resilience actions. These Assessments contribute to the advancement of science-based policies, plans, and programs to promote effective climate leadership in California. In 2006, California released its First Climate Change Assessment, which shed light on the impacts of climate change on specific sectors in California and was instrumental in supporting the passage of the landmark legislation Assembly Bill 32 (Núñez, Chapter 488, Statutes of 2006), California's Global Warming Solutions Act. The Second Assessment concluded that adaptation is a crucial complement to reducing greenhouse gas emissions (2009), given that some changes to the climate are ongoing and inevitable, motivating and informing California's first Climate Adaptation Strategy released the same year. In 2012, California's Third Climate Change Assessment made substantial progress in projecting local impacts of climate change, investigating consequences to human and natural systems, and exploring barriers to adaptation.

Under the leadership of Governor Edmund G. Brown, Jr., a trio of state agencies jointly managed and supported California's Fourth Climate Change Assessment: California's Natural Resources Agency (CNRA), the Governor's Office of Planning and Research (OPR), and the California Energy Commission (Energy Commission). The Climate Action Team Research Working Group, through which more than 20 state agencies coordinate climate-related research, served as the steering committee, providing input for a multisector call for proposals, participating in selection of research teams, and offering technical guidance throughout the process.

California's Fourth Climate Change Assessment (Fourth Assessment) advances actionable science that serves the growing needs of state and local-level decision-makers from a variety of sectors. It includes research to develop rigorous, comprehensive climate change scenarios at a scale suitable for illuminating regional vulnerabilities and localized adaptation strategies in California; datasets and tools that improve integration of observed and projected knowledge about climate change into decision-making; and recommendations and information to directly inform vulnerability assessments and adaptation strategies for California's energy sector, water resources and management, oceans and coasts, forests, wildfires, agriculture, biodiversity and habitat, and public health.

The Fourth Assessment includes 44 technical reports to advance the scientific foundation for understanding climate-related risks and resilience options, nine regional reports plus an oceans and coast report to outline climate risks and adaptation options, reports on tribal and indigenous issues as well as climate justice, and a comprehensive statewide summary report. All research contributing to the Fourth Assessment was peer-reviewed to ensure scientific rigor and relevance to practitioners and stakeholders.

For the full suite of Fourth Assessment research products, please visit www.climateassessment.ca.gov. This report contributes to energy sector resilience by providing a framework for assessing vulnerability of California's transportation fuel sector to weather-related events as well as assessing exposure to wildfires and flooding at both coarse (statewide) resolution and, for several vulnerable assets, very fine scale that fosters stakeholder engagement.

ABSTRACT

California's transportation fuel sector (TFS), whose assets supply crude oil from its source to end fuel users, will increasingly be exposed to extreme weather events including flooding and wildfire under climate change. Prior studies have not considered the TFS as one sector and its exposure and vulnerability to these weather events, nor have they projected and analyzed the exposure at spatial resolutions that are fine enough to inform stakeholders about the vulnerability of individual assets that are interconnected to reliably supply and distribute fuel. Therefore, we conceptualize the TFS into a physically and organizationally connected, multi-sector network. Using this network, we project and analyze climate-change-induced flooding and wildfire exposure at both coarse and fine spatial resolutions, across multiple temporal horizons and climate scenarios. We then assess the statewide TFS's exposure with the coarse resolution projections and discuss with various stakeholders about their assets' vulnerability using the fine resolution projections in areas of interest.

We find that transportation fuel product pipelines and central product distribution terminals are the most critical assets within the TFS network, and that the network is dependent on supporting sectors such as electricity and natural gas. Our statewide analysis identifies docks, terminals, and refineries as the most exposed TFS assets to coastal flooding, whereas roads and railroads are the most exposed assets to wildfire. The fine resolution models and the focus on different planning horizons (i.e. every 20-years between 2000 and 2100) facilitate our discussion with the stakeholders, which shows that they have implemented and plan to adopt hardening measures (improvements to physical infrastructures) and resiliency actions (improvements to behavioral responses at the organizational level) to adapt their infrastructures to these weather events, and that the fine resolution exposure projections are effective tools to facilitate stakeholder discussions. Overall, we find the TFS's vulnerability to flooding and wildfire is three-fold: the direct exposure and potential disruption of operations, the impact on its supporting assets, and the increased pressure on California's emergency management infrastructure. These findings will assist the TFS in adapting to the changing climate.

Keywords: Transportation fuel sector, climate change, extreme weather events, exposure, vulnerability, wildfire, flooding, high-resolution modeling, stakeholder engagement.

Please use the following citation for this paper:

Radke, J.D, G.S. Biging, K. Roberts, M. Schmidt-Poolman, H. Foster, E. Roe, Y. Ju, S. Lindbergh, T. Beach, L. Maier, Y. He, M. Ashenfarb, P. Norton, M. Wray, A. Alruheili, S. Yi, R. Rau, J. Collins, D. Radke, M. Coufal, S. Marx, A. Gohar, D. Moanga, V. Ulyashin, A. Dalal. (University of California, Berkeley) 2018. *Assessing Extreme Weather-Related Vulnerability and Identifying Resilience Options for California's Interdependent Transportation Fuel Sector*. California's Fourth Climate Change Assessment, California Energy Commission. Publication Number: CCA4-CEC-2018-012.

HIGHLIGHTS

- Our development of a transportation fuel sector (TFS) conceptual model advances the understanding of the connectedness and complexity of California's TFS. There is no formal definition of what constitutes a TFS, much less what the TFS represents at the California state level.
- Pipelines for refined transportation fuel products are the most critical asset and the greatest threat to breaking the flow of fuel within the TFS network. Many of these pipeline assets are the singular link between refineries and intermediate transshipment nodes or end node terminals with no redundancy in place. If these pipelines go out of service for an extended period of time, the TFS could suffer a debilitating or even devastating failure. An impact on a singular node or link, depending on where it is in the network, could result cascading and devastating impacts.
- Central distribution terminals are critical assets to the operational success of the TFS as many refineries transport fuels to such terminals via pipeline for further distribution. The two highest product throughput volumes in the TFS (post-refinery) occur at the Concord terminal in northern California and the Watson terminal in southern California. Here, cooperation exists between various companies and refined fuels from different refineries are mixed and further transported throughout the TFS. If a refinery goes offline for a period of time, fuels from other refineries can serve to make up the shortage and redundancy is achieved. However, if these individual terminals fail, the inability to move fuel in the system could seriously disrupt the TFS.
- Statewide hazard modelling and exposure analysis reveals broad patterns of TFS asset exposure that vary by hazard, asset type, and region. Our modelling represents the range of possible outcomes under the various climate scenarios. Our use of the full range of scenarios in our flooding and wildfire modelling is critical in gaining the attention of stakeholders who might otherwise discount results from a single specific climate scenario or model.
- Our introduction of fine spatial resolution modelling of flooding and wildfire allows for more accurate exposure evaluation for specific TFS assets at a local scale and is more effective for engaging stakeholders in discussions of asset vulnerability. At this fine spatial resolution, TFS stakeholders clearly recognize specific components of their assets on the ground in relation to modelled flooding or wildfire conditions and can more effectively consider adaptation and strategic planning.
- Many of the retrofitting and design adaptive measures that are mentioned by stakeholders are driven by hazardous material regulations. This is relevant because owners and operators of TFS infrastructure consider these regulations as windows of opportunity to implement infrastructural adaptation measures. These windows of opportunity for implementing adaptation measures predominantly focus on environmental vulnerability in relation to spills and not necessarily the vulnerability of the TFS as a critical infrastructure.

- Repeated impact from extreme weather events may lead to the relocation of a TFS asset to a lower-risk area. However, this option has very high costs and was only mentioned by stakeholders as an option for key TFS links, mostly railways and roads.
- Not knowing the vulnerability of interconnected assets, on which pipeline managers, for example, are dependent, increases uncertainty and is a very real threat to the resilience of the TFS pipeline system. For example, if electricity is interrupted, the pipeline pumps fail to operate, fuel is not transported, the intermediate transshipment nodes fail, and that section of the TFS is broken.
- The uncertainties in future coastal flooding and wildfire from different climate scenarios are relatively small at the beginning of the century (i.e. 2000-2020 period) but become much more pronounced by 2100. Thus, similar uncertainty patterns in TFS asset exposure to coastal flooding and wildfire are also observed. Moreover, given the coarse resolution of the statewide flooding and wildfire modelling, the results are primarily appropriate to interpret at the statewide level. Fine resolution modelling is more appropriate for localized asset exposure analysis.
- TFS stakeholders are focused on the immediate future and they consistently request higher resolution modelling of the 2020-2040 period, consistent with their near-term investment and asset life cycles and in recognition of the fact that some of their critical assets are already located in current-day flood and fire risk areas.
- Our research shows the TFS is extremely complex, both physically and organizationally. The sector functions because of contracts and agreements between all stakeholders. Because of this complexity, no one stakeholder or group has a comprehensive overview of all of TFS or has ability to respond reliably to all exposure risks and uncertainties. The uncertainty of what the future holds suggests that, in terms of developing resiliency to future exposure, there should be more coordination within the TFS and with interconnected sectors.

WEB LINKS

- <http://keystone.gisc.berkeley.edu>

TABLE OF CONTENTS

ACKNOWLEDGEMENTS	i
PREFACE	iv
ABSTRACT	v
HIGHLIGHTS	vi
TABLE OF CONTENTS.....	viii
LIST OF FIGURES.....	xiv
LIST OF TABLES	xvi
ACRONYMS.....	xvii
GLOSSARY	xix
1: Introduction	1
1.1 Transportation Fuel Sector (TFS)	1
1.1.1 Distinctive Aspects and Importance of TFS Assets.....	1
1.2 Scope of Analysis	2
1.3 Exposure to Flooding and Wildfire	4
1.3.1 Combined Effect of Extreme Weather Events.....	6
1.3.2 Operational Threats to TFS Under Climate Change	7
1.4 Assessment of Impacts on Assets	9
1.5 Modeling Extreme Weather Events.....	12
1.5.1 Climate Change Scenarios	12
1.5.2 Flood Modeling Methods Overview	14
1.5.3 Wildfire Modeling Methods Overview.....	14
1.6 Stakeholder Driven Vulnerability Assessment.....	15
1.7 Innovative Approach.....	16
1.8 Structure of Report.....	17
2: Transportation Fuel Sector - Assets, Operation and Organization	17
2.1 Conceptualizing the TFS – Definitions and System Boundaries	17
2.1.1 TFS Supply Chain Overview	18
2.1.2 Conceptual Model.....	21

2.2 Key Assets	23
2.2.1 Assets Found Across Subsystems	23
2.2.2 Pre-refinery: Crude Oil Subsystem.....	25
2.2.3 Refinery Assets	27
2.3 Vital Inputs and Interconnected Infrastructures: The Case of Refineries	30
2.4 TFS Organizational and Institutional Frameworks.....	32
2.4.1 TFS Governance: Private and Public Spectrum Ownership and Operations	32
2.4.2 Relationships Between Fuel Market Drivers, Emergency Management and Regulations	35
3: Transportation Fuel Sector Exposure to Flooding and Wildfire Under Climate Change	47
3.1 Future Scenarios	47
3.2 Exposure of Transportation Fuel Sector Assets	48
3.2.1 TFS Assets Exposed to Flooding	48
3.2.2 TFS Assets Exposed to Wildfire	61
3.3 Measuring Exposure and Impacts Using Networks	78
3.3.1 A Network Example: Coastal Flooding Case Study in the San Francisco Bay Area	79
3.3.2 Steps Towards Network Modeling.....	79
4: Stakeholder Engagement.....	83
4.1 Stakeholder Profile.....	83
4.2 Areas and Assets of Concern.....	85
4.3 Adaptation Interests and Efforts.....	88
4.3.1 Currently Implemented or Under Implementation	89
4.3.2 Implementation Interest.....	90
4.4 Converging Exposure Projections and Planning Time Horizons	91
4.5 Concerns about Climate Model Resolutions and Effective Stakeholder Engagement.....	91
4.6 Engagement with Kinder Morgan, Inc.	92
5: Conclusions and Future Directions	94
5.1 Conclusions.....	94
5.1.1 TFS Conceptual Model	94
5.1.2 Flood and Fire Exposure under Climate Change	96

5.1.3 Stakeholder Conclusions.....	101
5.2 Discussion	104
5.2.1 Methodological Implications of the Modeling Approach.....	106
5.3 Suggestions for Future Research.....	107
5.3.1 Flooding.....	107
5.3.2 Wildfire.....	108
5.3.3 Stakeholder	108
5.4 Value of Our Methods.....	109
5.4.1 Flooding.....	109
5.4.2 Wildfire.....	110
5.4.3 Stakeholder	110
6: References.....	112
APPENDIX A: Transportation Fuel Sector.....	1
A.1 Introduction: Steps Toward Conceptualization	1
A.2 Data Sources and Discrepancies	1
A.2.1 Nodes: Assets Where Commodities are Processed, Transferred and/or Stored.....	2
A.2.2 Links: Key Transportation Assets Along, Over, or Through Which Commodities are Moved.....	6
A.2.3 Asset Area/ Polygon Information.....	7
A.2.4 Possibilities for Enriching the TFS Layers	7
A.2.5 Summary of TFS layers	8
A.3 TFS Network Model and Flooding Exposure in the San Francisco Bay Area.....	10
A.3.1 Introduction	10
A.3.2 TFS Network Modeling Process	12
A.3.3 TFS Network Flooding Exposure Analysis	15
A.4 References	25
APPENDIX B: SELECTION OF SCENARIOS, SITES, AND ANALYSIS PERIODS.....	1
B.1 Deriving Estimates of Future Conditions.....	1
B.1.1 Climate Projections Based on RCPs and GCMs	1
B.1.2 Bias Correction and Downscaling GCM Projections	4

B.1.3 Hourly Sea Level Projections	4
B.1.4 Land Use and Land Cover Projections	5
B.1.5 Defining Scenarios to Model	6
B.2 Selecting Periods of Analysis	7
B.3 Selecting Events to Model at Local Scales	8
B.4 Selecting Regions to Model at Local Scales	8
B.5 References	10
APPENDIX C: FLOODING DATA, METHODS, AND RESULTS	12
C.1 Introduction	12
C.2 Data	16
C.2.1 Climate Scenarios	16
C.2.2 Topography and Bathymetry Data	19
C.2.3 Other Environmental Datasets	24
C.3 Methods	25
C.3.1 Regional-scale Coastal Flooding Model	25
C.3.2 Local-scale Models	31
C.4 Flooding Exposure Analysis	33
C.4.1 Selection of Scenarios for Detailed Analysis	34
C.4.2 Calculating Exposure	36
C.4.3 Flooding Exposure by Asset Operator and Geography	36
C.4.4 Uncertainties	48
C.5 References	50
C.6 Appendix C Supplementary Tables	52
APPENDIX D: Wildfire Data, Methods, and Results	1
D.1 Wildfire Hazard, Threat, and Risk Assessments	2
D.1.1 Introduction to Modeling Wildfire for Hazard, Threat, and Risk Assessments	2
D.1.2 Modeling Uncertain Wildfire Futures	2
D.1.3 Overview of Multi-Scale Approach to Assessing Wildfire Hazards and Threats	3
D.2 Analysis of Historical, Near, Intermediate, and Long-Term Trends in California Wildfire	4
D.2.1 Introduction to California Wildfire History	4

D.2.2 California Wildfire Frequency, Size, and Severity Trends.....	5
D.2.3 Assessments of Current California Wildfire Hazard and Threat Levels	8
D.2.4 Wildfire Hazard and Threat Projections for California	13
D.2.5 Exploring Spatial and Temporal Patterns of Large Wildfire Threat- identifying Localized Hot Spots	21
D.2.6 Modeled Wildfire Threat Rating System	25
D.2.7 Downscaling Westerling’s Wildland Fire Futures to One Square Kilometer.....	37
D.2.8 Application: Modeled Wildfire Threat Rating System and the TFS	37
D.2.9 Tree Mortality and Wildfire	43
D.3 High Resolution Wildfire Behavior Modeling.....	49
D.3.1 Introduction: High Resolution Wildfire Behavior Modeling.....	50
D.3.2 Model Inputs	50
D.3.3 Wildfire Behavior Simulation.....	52
D.3.4 Elevation Surfaces	55
D.3.5 Classification of Fuels.....	56
D.3.6 Ancillary FlamMap Inputs	70
D.3.7 Vegetation Management	72
D.3.8 High Resolution Wildfire Modeling Results.....	77
D.3.9 Model Validation	90
D.3.10 Future Research: High Resolution Wildfire Behavior Modeling	99
D.4 References	101
D.5 Appendix D Acronyms	104
APPENDIX E: Transportation Fuel Sector Stakeholder Data Collection Methods.....	1
E.1 Introduction.....	1
E.2 Stakeholder Engagement Process: Population Sampling and Milestones of Data Collection	1
E.2.1 Stakeholder Engagement Process: Data and Documents	4
E.3 Discussion Formats and Goals.....	6
E.4 Discussion Guide Description	7
E.4.1 Guide Narrative	7
E.5 Challenges of the Applied Process and Lessons Learned.....	11

E.6 Conclusion	12
E.7 References	13
E.8 Discussion Guide	14
APPENDIX F: Vulnerability of Alternative Transportation Fuels to Coastal Flooding and Wildfire in California: Hydrogen Fuel Case Study	1
F.1 Introduction	1
F.2 Overview of the Hydrogen fuel’s regulations and infrastructure in California.	1
F.2.1 Hydrogen Fuel Infrastructure Regulation.....	1
F.2.2 California’s Hydrogen Fuel Supply-Chain	3
F.3 Statewide Exposure of Hydrogen Fueling Stations in California to Wildfire and Coastal Flooding.....	5
F.3.1 Coastal Flooding Statewide Exposure	5
F.3.2 Wildfire Statewide Exposure	6
F.4 Hydrogen Fuel Stakeholder Engagement	7
F.5 Conclusions.....	8
F.6 References	10

LIST OF FIGURES

Figure 1. TFS supply-demand chain overview	19
Figure 2. California’s Transportation Fuel Sector conceptual modelError! Bookmark not defined.	
Figure 3. In-state crude oil origins.	26
Figure 4. TFS refineries interconnections: vital inputs and outputs.....	31
Figure 5. Long-haul TFS links in California: Pipelines, railways, and waterways	37
Figure 6. Short distance TFS links in California: Roadways.....	38
Figure 7. TFS terminals in California: Intermediate transshipment nodes.....	39
Figure 8. San Francisco Bay Area TFS hub terminal examples.	40
Figure 9. California’s oil fields and active oil wells: Crude oil origin nodes.....	41
Figure 10. TFS refinery nodes in California	42
Figure 11. San Francisco Bay Area TFS Hub Refineries.....	43
Figure 12. Port and dock nodes in California	44
Figure 13. Airports in California: Jet fuel demand nodes	45
Figure 14. Gas stations in California: Motor vehicle demand nodes	46
Figure 15. Statewide coastal flooding exposure during the high sea level events between 2000 and 2100.	50
Figure 16. Modeled flooding exposure classes for twenty-year periods between 2000 and 2100, zoomed to San Francisco Bay Area and Sacramento-San Joaquin Delta in Northern California, and Long Beach – Huntington Beach in Southern California.	52
Figure 17. TFS assets’ exposure to flooding.....	55
Figure 18. Contrasting the two modeling resolutions, illustrated by the median scenario high sea level event simulated in Richmond, Northern California, during the 2020-2040 period.	58
Figure 19. Coastal flooding and inland flooding, illustrated by the median scenario high sea level event and median scenario rainfall event simulated in San Francisco International Airport, Northern California, during the 2020-2040 period.	60
Figure 20. Modeled present-day and future Wildfire Threat Ratings (MWTR) for twenty-year planning periods falling between 2000 to 2100.	65
Figure 21. Percentages of each TFS asset types exposed to Very High or Extreme MWTR classes during each 20-year period of analysis.	66
Figure 22. Percentage of each TFS asset type exposed to each MWTR class.....	68

Figure 23. Convergence of TFS link assets and land cover surface used in high-resolution fire modeling.....	71
Figure 24. Hauling Chart	73
Figure 25. Modeled fire intensity estimates for each asset type as percent exposure to each wildfire behavior threshold at Dutch Flat.....	74
Figure 26. Fire intensity modeled across the Dutch Flat landscape.....	74
Figure 27. Modeled flame length estimates for each asset type as percent exposure to each wildfire behavior threshold at Dutch Flat.....	75
Figure 28. Flame length modeled across the Dutch Flat landscape.	76
Figure 29. Modeled rate of spread estimates for each asset type as percent exposure to each wildfire behavior threshold at Dutch Flat.....	77
Figure 30. Rate of spread modeled across the Dutch Flat landscape.....	77
Figure 31. Routing simulation before-after illustrations	81
Figure 32. Map of betweenness centrality in San Francisco Bay area	82
Figure 33. Areas of concern mentioned during the TFS stakeholder discussions.....	87

LIST OF TABLES

Table 1 Scenarios assessed in this study and their components	13
Table 2 Overview of the models in this study, highlighting the hazards of interest, corresponding spatial scales of the models, climate-related drivers of the hazard, and results for hazard exposure.....	15
Table 3. General TFS assets categorized per node and link.....	23
Table 4. TFS assets in the crude oil commodity subsystem.....	25
Table 5. TFS assets per fuel commodity subsystem.....	28
Table 6. Estimated count of different TFS private owners and operators in California.....	34
Table 7. Contrasting between the two modeling resolutions in terms of total exposed area and percent area by different depth levels.	57
Table 8. Coastal flooding versus inland flooding in terms of total exposed area and area by different depth levels.....	61
Table 9 Modeled Wildfire Hazard Rating (MWTR) level definitions.	63
Table 10. TFS Organizational Categories	83
Table 11. Stakeholder knowledge pool categories	84
Table 12. Summary of areas and assets of concern.....	88

ACRONYMS

3Di	Three dimensional hydrodynamic model
AB	Assembly Bill
Bay Area	San Francisco Bay Area
BNSF	Burlington Northern Santa Fe Railways
BTU	British Thermal Units
CalOES	California Office of Emergency Services
Caltrans	California Department of Transportation
CARB	California Air Resources Board
CCTAG	California's Climate Change Technical Advisory Group
cm	centimeter
DLA	Defense Logistics Agency
Delta	Sacramento-San Joaquin Bay Delta
DOGGR	Division of Oil, Gas and Geothermal Resources
DOT	Department of Transportation
EIA	Energy Information Administration
Fourth Assessment	California's Fourth Climate Change Assessment
ft	foot/feet
GCM	General Circulation Model
GHG	Greenhouse gas
GIS	Geographic Information System
ha	hectares
IMTT	International Matex Tank Terminals
IPCC	Intergovernmental Panel on Climate Change
KM	Kinder Morgan, Inc.
km	kilometer/kilometers
LA	Los Angeles
LEED	Leadership in Energy and Environmental Design
LiDAR	Light Detection And Ranging
LOCA	Localize Constructed Analogs
LULC	Land Use and Land Cover
m	meter/meters
mm	millimeter
MOTEMS	Marine Oil Terminal Engineering Maintenance Standards
MWTR	Modeled Wildfire Threat Rating
NDA	Non-Disclosure Agreement
NFDRS	National Fire Danger Rating System
NPMS	National Pipeline Mapping System
NTSB	National Transportation Safety Board
NWCG	National Wildfire Coordinating Group
OCC	Orange Control Center
PADD5	Petroleum Administration for Defense District 5
PGE	Pacific Gas and Electric Company
PHMSA	Pipeline and Hazardous Material Safety Administration
PPP	Public Private Partnership

PVEA	Petroleum Violation Escrow Account
RCP	Representative Concentration Pathways
SCADA	Supervisory Control and Data Acquisition
SFPP	Santa Fe Pacific Pipeline
SLR	Sea level rise
SPE	Society of Petroleum Engineers
sq.	square
State	State of California
TAC	Technical Advisory Committee
TFS	Transportation Fuel Sector
UP	Union Pacific Railroad
U.S.	United States
USCG	United States Coast Guard
°C	Degrees Celsius

GLOSSARY

3Di: A hydrodynamic model (Stelling, 2012a) used in this project to model inundated areas during extremely high sea level events.

Andeavor: A TFS oil company formerly known as Tesoro.

California Transportation Fuel Sector (TFS): The infrastructure assets that are necessary to obtain crude oil, transport it to refineries, refine it into petroleum transportation fuels, and distribute those fuels within the state of California. It is considered a network made up of key locations (called *nodes*) and connections (called *links*)

Choke-points: Areas of critical operational TFS infrastructure or where intra-operational disruption could quickly lead to a major TFS failure.

Climate change: Refers to a change in the statistical distribution of weather patterns brought about by anthropogenic forced change in longer-term average weather conditions caused by human activity, as opposed to changes resulting from natural processes.

Coastal flooding: Is due to sea level rise, storm surge, and tides and is an indicator of climate change. This occurs when normally dry low elevation land is inundated by seawater. The extent of coastal flooding is curtailed by the topography of coastal land.

Commodity subsystems: Subsystems in this project's TFS conceptual model comprised of the nodes and links of the different transportation fuel commodities used in the state: crude oil, common vehicle fuel products, airport fuel products, maritime fuel products and gasoil.

Critical Infrastructures: Infrastructures that are vital to the security and daily wellbeing of the nation. In this case those responsible for petroleum production and distribution.

Exposure: By being in a particular situation or place, exposure is the condition of being subject to a hazard that represents a potential threat to property or lives. In this project, by their location, some TFS assets are open to potential damage due to their exposure to flooding and wildfire hazards.

Extreme weather-related events: The extreme weather-related events we discuss are flooding and wildfires under future climate change scenarios. There are three extreme weather-induced events this project focuses on: 1. Coastal Flooding (due to sea level rise, tides, and storm surge), 2. Inland Flooding (due to rainfall) and 3. Wildfires (due to fire in areas of carbon-rich vegetation and seasonally dry climates).

Flooding, coastal: Flooding caused by sea level-rise, storm surge, and tides under various climate change scenarios.

Flooding, inland: Flooding due to extreme rainfall under various climate change scenarios.

Gasoil: A partially refined product that is produced in a number of the State's refineries and sent to other refinery facilities for final processing into consumable fuel products.

General Circulation Models: We utilize the four GCMs selected by the Fourth Assessment (HadGEM2-ES, CNRM-CM5, CanESM2, and MIROC5) as they together cover a broad range of climate model projections.

Hauling Chart: A fire response characteristic chart indicating how fire behaviors may impact fire suppression.

Inland Flooding: Is due to inland moving tropical cyclones and thunderstorms with precipitation levels resulting in volumes of water on the land overcoming the capacity of the natural and built drainage systems to carry it through the watershed.

Intraconnected assets: The assets within the TFS network that includes, amongst others, production facilities, refineries, storage tanks, pumps, land and marine terminals, pipelines, rail, and road.

Interconnected sectors: The sectors on which the TFS processes of producing, transporting, refining and distributing the transportation fuels depend in order to sustain operations. This includes sectors such as those that provide electrical power, water, data communication, process inputs, and waste removal.

Interdependent assets: TFS assets that are interconnected and mutually dependent on each other in order for the TFS to be operational.

Links: Linear assets in the TFS that provide the connections between the TFS nodes. Commodities are moved along, over or through these assets. This includes pipelines, roads and railways.

Loading Racks: Loading racks in distribution terminals are key units responsible for trans-loading finished fuel products from pipelines and storage tanks into tanker trucks for further distribution.

Multimodal network: Parts of the TFS network in which two or more types of transportation modes for the transportation fuel commodities are possible.

Network analysis: The analysis of the relationships between discrete objects. In this project the objects that were analyzed are the TFS nodes. By examining the centrality of the node, its importance within the TFS network is described. Five centrality metrics are used and applied on the TFS network, serving as an example to understand the impact of coastal flooding on the TFS by running routing simulations within the network.

Nodes: Areal, fixed location assets that make up the TFS where commodities are processed, transferred, and/or stored. This includes *marine terminals* at which a large volume of crude oil enters the state's TFS, *refineries* to which crude is delivered and from which products are delivered, *central distribution terminals* (such as Concord and Watson) where various operators pool their fuels to be distributed to dispensers.

Pre-Refinery Process: Part of the project's TFS conceptual model, which consists of the Out-of-state and California crude oil commodity subsystems. Within these subsystems the essential assets that transport the crude oil to the refineries (crude oil supply) are found. This includes: marine terminals, rail terminals, CA oil wells, pipeline pump stations,

gathering stations, railways, waterways, crude oil gathering pipelines and crude oil pipelines.

Post-Refinery Process: Part of the project's TFS conceptual model, which consists of three commodity subsystems: vehicle fuel, aviation fuel and marine fuel. Within these subsystems the essential assets that transport the produced fuels from the refineries to the demand destinations (fuel product demand) are found. This includes; vehicle fuel stations, break out tanks, pump stations terminals, airports, ports, product pipelines, waterways and roadways.

Spatial temporal modeling: Modelling done to analyze and predict exposure to extreme weather events of flooding and wildfire over space and through time. In this project the spatial extents are *statewide* and *local*. Temporally, the focus is on different planning horizons of every 20-years between 2000 and 2100.

Terminals: Any facility (node) in this project's TFS conceptual model where a liquid bulk transportation fuel commodity originates, terminates, or is handled in the supply and distribution process.

TFS - Transportation Fuel Sector: The network of infrastructure assets within California necessary to obtain crude oil, transport it to refineries, refine it into petroleum transportation fuels, and distribute those fuels within the state.

TFS stakeholders: The organizations that are in that network and directly handle the commodity itself by extraction, and/or transportation of crude oil to the refineries, refining and/or then transporting the finished product (to include a variety of fuels) to intermediate and end terminals.

TFS Core: This project's label for representatives of industry stakeholders that own and operate key TFS assets.

TFS Dependent: This project's label for representatives of organizations that provide services on which the TFS core organizations rely heavily.

TFS Knowledgeable: This project's label for representatives of groups that regulate and or research the TFS core organizations.

Transloading: The process of transferring a commodity from one mode of transportation to another.

Transportation fuels: Fuels used to move people and goods for personal and commercial purposes. In this project the main focus is on the supply and demand of crude oil-derived fuels – gasoline, diesel, propane, jet fuel, kerosene and heavy oil – that are used in the state for transportation via vehicles, aviation and, to a smaller extent, marine vessels.

Wildfire: A sweeping and destructive conflagration in wilderness or rural areas, such as a forest, that spreads rapidly through woodland or brush and causes great damage. It is exacerbated by hot and dry climates.

1: Introduction

This research examines and assesses the impact of flooding and wildfire on California's Transportation Fuel Sector (TFS). The TFS is a network of infrastructure assets that comprise the fuel supply chain from source to end use in the State. In this study, we model the exposure of TFS assets to potential extreme weather-related flooding and wildfire events under future climate change scenarios and engage industry stakeholders to explore the sector's vulnerability. In doing so, we provide a baseline to inform planners and policymakers to proactively mitigate potential future impacts from such extreme weather events.

We construct an organizational schematic of this complex sector and map it – along with model projections of climate-related impacts – on the Californian landscape to predict where, when, and under what circumstances TFS assets may be compromised. In addition to providing TFS stakeholders with a baseline for their future strategic planning purposes, our results have been disaggregated by period to better reflect already existing near- and longer-term cycles for operations, multi-year budgeting and risk management, long-term investment, and equipment/plant depreciation. By engaging collectively and individually with TFS stakeholders, we provide finer resolution results of more relevance to these ongoing scheduled cycles in the TFS. In these and other ways discussed in the report, the results inform mitigation strategies to avoid systematic failures or severe service disruptions of the TFS and thereby better serve the citizens of California.

1.1 Transportation Fuel Sector (TFS)

Although we recognize a growing trend in alternative fuels, the majority of the State's transportation fuel consumption is sourced from crude oil - an estimated 94% in 2014 (Bahreinian et al., 2015). Therefore, this study defines the California Transportation Fuel Sector as the infrastructure assets necessary to obtain crude oil, transport it to refineries, refine it into petroleum transportation fuels, and distribute those fuels within the state. California's TFS assets therefore are part of an intranetworked physical network that includes, among others, production facilities, refineries, storage tanks, pumps, land and marine terminals, waterways, pipelines, railways, and roads. TFS stakeholders, in turn, are organizations in this network that directly handle crude-oil and derived fuels from extraction, to transportation of crude oil to refineries, refining, or transporting the finished product (to include a variety of fuels) to terminals and end users.

The weather-related events of extreme flooding and wildfires have disrupted the production, transportation, refining, and distribution of transportation fuels by damaging related assets (see U.S. Department of Energy, 2014). They may, in fact, lead to prolonged closure of transportation routes due to smoke or flooding production loss from crude wells; and evacuation and closure of refineries for several days (U.S. Department of Energy, 2014).

1.1.1 Distinctive Aspects and Importance of TFS Assets

Transportation fuels are used to move people and goods for personal and commercial purposes, and California is a major consumer of these fuels. Petroleum products (including gasoline, diesel, jet fuel, residual fuel oil and propane), biofuels (including ethanol and biodiesel), natural gas, and electricity (from various sources) are the different types of energy sources (or fuels) for

transportation in the State (Bahreinian et al., 2015; U.S. Energy Information Administration, 2015a). When benchmarking the consumption of petroleum products derived from crude-oil, California ranks as the third largest gasoline consuming market in the world, after China and the United States (U.S.) as a whole (Western States Petroleum Association, 2017). The State was also the third-largest producer of crude oil among the 50 states in 2016, accounting for about 6% of total U.S. production. As of January 2017, California ranked third among the states in oil refining capacity, with a combined capacity of approximately 2 million barrels per day at the State's operable refineries (U.S. Energy Information Administration, 2017c). This accounts for approximately one-tenth of the total U.S. refining capacity (National Academy of Sciences, 2017). More specifically, in 2015 California accounted for one-fifth of the jet fuel consumption in the U.S. (U.S. Energy Information Administration, 2017c). With a state population that is forecasted to grow to 48 million people by 2040, California's demand for, and reliance on, transportation fuels is expected to increase (Western States Petroleum Association, 2017).

Given the State's reliance on transportation fuels, along with its role in producing them, a reduction in their supply would result in cumulative economic ripple effects, likely damaging major state industries and the greater California economy (Western States Petroleum Association, 2017). According to (Schremp, 2016b, 2017a) a catastrophic disaster in the greater San Francisco Bay Area or Los Angeles regions that causes a significant loss of production from Northern or Southern California refineries and/or diminishes the ability to transport refined products from these facilities has a high probability of curtailing or halting transportation fuel supply altogether. The pipeline systems that transport these fuels can generally operate only if fuel products are available to push liquid through the system, making continuous supply of refined products critical to operations. However, such continuous supply can be challenging in the face of a major disruption, as California has an approximately three-day supply of transportation fuel on hand.

While a major producer and consumer of oil and refined transportation fuel products, California's market is isolated by time, distance, and product characteristics from alternative sources of re-supply during unplanned refinery outages. The State requires its motorists use a specific blend of motor gasoline called California reformulated gasoline, a composite that is intended to help reduce emissions from motor vehicles. Locating and transporting replacement motor gasoline that conforms to California's strict fuel specifications from overseas can take several weeks and such disruptions can drive up wholesale and retail prices significantly (Hamilton, 2015; Schremp, 2016b; U.S. Energy Information Administration, 2017c, 2017d).

Along with the impact within the State, disruptions to California's Transportation Fuel Sector are more than likely to have effects beyond its borders. Pipelines connect California refining centers to out-of-state distribution terminals that provide 85% of the transportation fuel supply in Nevada and 45% of the supply in Arizona (Schremp, 2016b). While these states have connections to other refineries in locations such as Utah and Texas, those connections are less likely to quickly replace a large volume shortfall from California.

1.2 Scope of Analysis

Extreme events such as earthquakes happen with little warning and it is reasonable to assume that climate change will have no great impact on the occurrence of these events. However, climate change will impact the frequency and severity of extreme weather induced events such

as flooding and wildfires through increases in temperature, sea level rise, and changes in precipitation. Our study specifically measures and models the potential exposure of TFS infrastructure to extreme flooding and wildfires influenced by climate change. Our modeling effort is statewide, with a higher-resolution focus on where the events may have the greatest impact on critical TFS assets. We also cover a spectrum of climate change scenarios and a time span from 2000 to 2100.

In order to model the exposure of TFS infrastructure, we first define the sector, identify the assets involved, and develop a geospatial dataset to digitally represent those assets. The TFS is represented as a network; first as a schematic characterizing the intra-connectedness within the sector itself, and second as spatial data embedded within the geography of California. We then model and analyze flooding and wildfires based on a range of California's Fourth Climate Change Assessment (Fourth Assessment) climate projections (D. Pierce, Cayan, & Dehann, 2016). To determine where the greatest exposure to extreme weather-induced events is likely to occur now and move forward to the end of the century, we model and analyze the model results of vast regions of California (statewide). Next, we model at a much finer spatial resolution in selected locations where TFS assets coincide with the statewide flood and wildfire projections, so that we can better understand the exposure at the individual asset spatial scale. This provides more pertinent results for the ongoing operations, investment, and planning cycles of those assets.

While we model the exposure of TFS infrastructures, it is beyond the scope of this study to model flooding and wildfire impacts on sectors that are interconnected with the TFS and critical to its performance and operations. Interconnected sectors are those on which the process of producing, transporting, refining, and distributing the transportation fuels depends. They include the electrical power, water, data- and telecommunication, process inputs, and waste removal sectors needed by the TFS to sustain operations. More details of the links between the TFS and these sectors are discussed in Chapter 2. However, we do engage with TFS stakeholders to discuss their dependence, vulnerability, and resilience to failures of the interconnected sectors' assets.

We model flooding and wildfire in selected locations at a fine spatial resolution of 5 meters (m) or 16.4 feet (ft), so that the TFS stakeholders can recognize their individual assets at risk of exposure and are able to assess the danger and produce more targeted strategic, shorter-term plans and responses. We select locations for fine resolution modeling where we identify areas of critical operational TFS infrastructure (choke points). In addition, we use 1 m (3.28 ft) resolution data to identify and include objects such as buildings and trees as model inputs. We argue that our model results support the need for more accurate impact assessment and mitigation planning strategies.

In order to cover a broad range of climate projections, we model and analyze flooding and wildfire under two Representative Concentration Pathways (RCPs), four General Circulation Models (GCMs), three probabilistic sea level rise (SLR) scenarios for flood modeling, and three land use and land cover (LULC) scenarios driven by population growth for wildfires, as recommended by the Fourth Assessment research team (D. Pierce et al., 2016). Our results represent a broad range of possible future exposure to flooding and wildfire and help document the chronic impacts of climate change on TFS infrastructure. These results are presented to

stakeholders for their consideration and strategic response. We document what is learned from those discussions regarding the vulnerabilities and resilience of the TFS as a whole.

With our results on potential exposure of TFS assets to floods and wildfires, we hold discussions with TFS stakeholders concerning the sector's vulnerability to and resilience under future climate predictions. These discussions help identify the conditions under which TFS assets, operations, and interactions are subject to negative outcomes from exposure to flooding and wildfire. This, in turn, gives us a starting point for discussing resiliency - how asset operators (and the sector as a whole) can mitigate, or are already mitigating, against the possible negative outcomes. Resilience is not just about better recovery from a shock; it is also about being better moving forward. Beheshtian, Donaghy, Geddes, & Rouhani (2017) assert that resilience is a system's property to better withstand and absorb, efficiently adapt to, and quickly/cheaply recover from the inoperability imposed by extreme events. They also state that enhancing the resiliency of infrastructure is a process of complementary activities that takes place before, during, and after disruption. With this study we model potential exposure and discuss vulnerabilities to facilitate further discussion about mitigation strategies.

1.3 Exposure to Flooding and Wildfire

After identifying TFS infrastructure assets and building a geospatial dataset to represent those assets, we spatially model the potential exposure of TFS assets to three extreme weather-induced events:

1. Coastal Flooding (due to sea level rise, storm surge, and tides)
2. Inland Flooding (due to extreme rainfall)
3. Wildfires (due to fire in areas of flammable vegetation and seasonally hot and dry climates)

These events all may cause damage to TFS assets or to assets of its interconnected sectors. Damage can lead to disruption in production, transportation, and distribution of transportation fuels, which in turn, can ripple through California's economy (see box).

Examples of ripple effect

- Hurricanes such as Katrina and Rita (2005), Irene (2011), Sandy (2012), and Harvey, Maria, and Irma (2017) influenced the affected areas' transportation fuel sectors by causing flooding (coastal and inland) which led to disruptions in supply, production, and transportation of products (Devika Krishna Kumar & Jarrett Renshaw, 2017; U.S. Senate, 2006). The disruptions led to increased product prices and affected downstream stakeholders such as petrochemical plants (U.S. Senate, 2006) and retail gas consumers (U.S. Energy Information Administration, 2017a).
- The Blue Cut wildfire (August 16, 2016) disrupted California's TFS. It burned 37,000 acres (57.8 square miles) and stalled both railway and highway transport through Cajon Pass for 24 hours. Preliminary assessments from the California Trucking Association (as cited in Uranga, 2016) estimated the wildfire cost the shipping industry in Southern California as much as \$1 million per day (Uranga, 2016).

The actual extent to which TFS assets are exposed to flooding or wildfires depends on a number of factors. The first set of factors relates to the location of the assets. For example, refineries and terminals in the state are often located in urban areas near waterways (coast, bay, or river). This makes them naturally vulnerable to sea level rise and/or inland flooding but less at risk of exposure to wildfires because buildings and paved structures dominate the landscapes and there is limited vegetation.

The second set of factors concerns mitigation measures already taken near an asset. Many asset owners and operators ensure reduction or removal of vegetation near TFS assets to limit wildfire exposure. Levee improvement is also a common strategy employed to protect existing assets against the rising sea. For example, the *Airport Perimeter Dike FEMA and Seismic Improvements Project* is underway at Oakland Airport in response to sea level rise and includes FEMA certification requirements for 100-year flood protection.

The distinct nature of flooding and wildfires also needs to be considered, and mitigation/resilience strategies should be customized based on the hazard. Coastal flooding occurs when sea levels rise accompanied by storm surge(s). In this case, SLR is a rather slow, punctuated event for which stakeholders can prepare. For example, the San Francisco Bay Area is projected to experience a SLR above year 2000's mean sea level of between 12.9 and 13.7 centimeters (2.4 to 5.4 inches, median estimate under RCP 4.5 and 8.5 respectively) by 2040 and between 73.7 and 136.6 cm (2.4 and 4.5 ft, median estimate under RCP 4.5 and 8.5 respectively) by 2100 (Cayan, Kalansky, Iacobellis, & Pierce, 2016). While the absolute amount of SLR seems

large, this is a continuous change over an extended period and allows time for adaptation. Changes in extreme rainfall, the driver for inland flooding, can be even smaller. For example, the Mt Diablo Creek watershed (i.e. location of a major refinery and a major terminal) is projected to have the highest daily rainfall between 76 and 79 millimeters (mm) between 2020 and 2040, and between 73 and 102 mm between 2080 and 2100 (D. Pierce et al., 2016). Wildfire behavior is also context-dependent, such that wildfire intensity, flame length, and rate of spread are a function of type of vegetation and its moisture content, as well as topography, wind, and weather. Climate changes affect fuel type, condition, and amount by altering temperature and relative atmospheric humidity patterns. Westerling's (2018) projections show that wildfire frequency will remain the same or decrease at least until the end of the century in many of California's urban and desert regions. In contrast, in grass, shrub, chaparral, and forest dominated areas wildfires are expected to increase every few years (Westerling, 2018) such that rare events today will be more commonplace tomorrow. A number of climate-related causes contribute to this, including increased temperatures and extended periods of drought (Meigs, Zald, Campbell, Keeton, & Kennedy, 2016). Given the increasing wildfire trend, a growing population, and development expanding into forested regions, risks to communities and infrastructures will continue to increase (McGee, McFarlane, & Tymstra, 2015).

Extreme weather events have varying response and planning horizons. While mean sea level rise and wildfires are projected to increase over time, the frequencies of these two events are not in synchrony. Wildfires are expected to occur more frequently than flooding. Wildfires and inland flooding require short-term emergency responses, whereas adaptation to coastal flooding presents an opportunity for longer-term planning. Finally, in the long run, the predicted increase in occurrence and increase in intensity of extreme weather events pose the added challenge to TFS network of disruptions in California leading to sector-specific failure.

1.3.1 Combined Effect of Extreme Weather Events

While it is beyond the scope of the research and this analysis to assess the potential for TFS assets to be exposed to landslides or debris-flows, such events related to flooding and wildfire have the potential to occur in regions of California that contain TFS assets. Heavy precipitation and loss of vegetation can contribute to such slides, especially if a wildfire precedes heavy rains. The combination of events has caused immense damage to homes, lives, and infrastructure (Dolan, 2018; Lee, Medina, & Parlapiano, 2018; Los Angeles Times Staff, 2018; L. McDonald, 2018). Unfortunately, due to California's Mediterranean climate, the arrival of the annual wet period often coincides with the end of wildfire season. Bill Patzert, climatologist at NASA JPL, characterizes the seasonal shifts as, "four seasons in California - drought, followed by fire, followed by floods, followed by mudslides" (Castillo, 2018).

Extreme rainfall events that contribute to inland flooding decrease the amount of resistance hillslopes have to shearing under gravity and other stresses (Caine, 1980). When slopes do fail, rock, soil, mud, and vegetation are mobilized and can be transported great distances, especially in areas where steep slopes and large amounts of elevation relief are present (Jakob & Hungr, 2005). Such conditions have been particularly apparent in coastal areas of Southern California (Cannon, Gartner, Rupert, & Michael, 2004; Cleveland, 1973; Wells, 1987) but can be found throughout the State.

In addition, loss of vegetation and other forms of combustible groundcover during a wildfire may well increase the portion of rainfall that infiltrates subsurface materials, decrease the shear

strengths of hill-slopes, and render wetted areas more likely to slide (Campbell, 1974). For precipitation not absorbed into soils or parent materials underlying recently burned areas, the removal of groundcover by combustion allows storm-water runoff to travel at higher velocities and with greater erosive force than would be observed under pre-fire conditions (DeBano, 1989). In certain situations, soils become hydrophobic, lose hydraulic conductivity, and repel rainfall in response to exposure to high intensity burns (DeBano, 2000). During periods of intense rainfall, torrents of runoff can dislodge and transport debris downhill in burned areas, often with ruinous effects, see box below.

Examples of landslides and debris-flows in California

- Feb 1998: A rainstorm that was part of a warm phase of the El Nino Southern Oscillation brought almost one half-foot of precipitation in just thirty hours across much of the San Francisco Bay Area. This event saturated hillslopes and triggered landslides and debris flows that resulted in approximately 158 million dollars in public and private economic losses (Coe, Godt, & Tachker, 2004; Godt et al., 1999).
- Dec 2017/ Jan 2018: Santa Barbara County was impacted by an immensely damaging revolution of the wildfire-rainstorm cycle where the largest wildfire ever to burn entirely within the State's boundaries set the stage for landslides and massive debris-flows (Brown, 2018; Federal Emergency Management Agency, 2018). TFS assets affected by the landslides and debris-flows included Highway 101, a major trucking route.

1.3.2 Operational Threats to TFS Under Climate Change

The ripple effects mentioned above can result in a disruption of the complex intraconnected nature of the assets within the TFS network. The network is vulnerable at key locations (network nodes) and connections (network links), where disruption could result in complete shutdown of significant sections of the system with significant impacts to fuel distribution.

Through our discussions with stakeholders, we consider what may happen to operations of various critical TFS assets when they are exposed to flooding or wildfire and how this could affect the entire sector. This includes looking at the operations of marine terminals where a large volume of crude oil enters the State's TFS, refineries where crude oil is delivered and from which products are exported, central distribution terminals (such as Concord and Watson) where various TFS operators pool their fuels to be distributed to dispensers in the region, other terminals where liquid bulk transportation fuel commodities originate, terminate, or are handled in the supply and distribution process, the "links" (i.e. pipelines, roads and railways) between those fixed network "nodes," and all other assets that support the functioning of TFS "nodes" and "links".

Consideration of how flood and wildfire exposure to certain TFS assets affects operation of the entire TFS is important because all TFS stakeholders we canvassed share a common operational

goal: maintaining the supply chain and keeping fuel moving through the system to serve paying customers. Communication and decision-making take place in real-time and at the operational level between and among intraconnected TFS stakeholders by virtue of agreements, contracts, and markets to ensure that fuels keep moving. This helps sustain a resiliency in joint TFS operations in managing the production and distribution of products in the system. Locations/assets considered choke points or critical nodes and links are well known to the TFS stakeholders. For example, stakeholders point out that outputs of the TFS' operations need serious consideration. They indicate that the disposal of petroleum coke is considered an underestimated choke point of TFS' output system, given that there are only a few alternatives for its disposal. This major by-product of oil refining needs to be disposed of regularly every 15-20 days through the State's port and waterway transportation infrastructure. In addition, these choke points or critical nodes and links are often the subject of discussion during emergency response table tops and workshops where strategic response and planning is undertaken to offset temporary disruption in the flows of fuel, quickly repairing damage, or building redundancy into the TFS.

Examples of TFS operations considered:

- We consider what may happen to *refinery* operations during extreme weather-induced flooding because refinery operations are very vulnerable then, as witnessed in Houston Texas during Hurricane Harvey in 2017. If systems delivering crude oil or distributing finished product are disrupted, limited onsite storage capacity would force a refinery to cease operations. In addition, electricity, natural gas, and water are essential real-time inputs to the refining process and a loss of inputs from one of these strategically interconnected sectors could force a shutdown in short order. For example, although cogeneration (combined heat and power to create electricity) is common, it is not enough to maintain refinery operations.

The refining process generates a number of by-products, such as petroleum coke, that need to be removed from the refinery site. Most California refineries are located near ocean water bodies where the by-products are removed via ship or barge. An indefinite disruption in this process would cause a refinery shutdown.

- *Pipelines* are the main arteries of the TFS. If disrupted, the flow of finished product in the entire system is dramatically altered as few pipeline redundancies are built into the system. If the disruption lasts for days, access to fuel becomes critical in the region affected (J. Settles, personal communication, February 8, 2018). Although emergency preparedness exercises practice short-term repairs to the distribution network (such as truck, rail and marine transportation), it would be perilous to assume these repaired operations would be effectively maintained over any longer periods.

During extreme weather events pipeline operations are most vulnerable to pump failure due to loss of power from interconnected electrical partners. Where backup generators exist, they are mainly in support of pipeline communications and keeping the loading racks operational at distribution terminals. Loading racks in distribution terminals are key units responsible for trans-loading fuel products from pipelines into tanker trucks for further distribution (Langenkamp, 2014). Aboveground pumps and valves are also susceptible to damage, which in turn could stop the flow of fuel.

1.4 Assessment of Impacts on Assets

With respect to uncertain futures of infrastructure due to changes in climate, different approaches are supported and advocated in the U.S. by the federal government, state

governments, national organizations, and TFS-related industries. The research approach we undertake follows, to some extent, recommendations given by the Society of Petroleum Engineers (SPE) and the U.S. Department of Transportation (DOT)'s guide for climate change adaptation framework; we undertake data-driven analyses, assess risk of infrastructure exposure, and develop a dialogue with TFS stakeholders to determine resiliency options.

The Society of Petroleum Engineers (SPE) published a 2010 report that recognizes climate change, its impacts on various ongoing environmental trends, and the importance of adaptation planning by the oil industry (Pasteris, 2010). The authors recommend a "value chain adaptation approach," the steps of which include:

- *Projecting* physical climate change impacts of greatest significance in key locations of concern to the company in a relevant timeframe;
- *Identifying* opportunities and risks to new projects and existing operations based on the projected impacts;
- *Identifying* and *assessing* potential design modification, technologies, and other solutions to mitigate risks and leverage opportunities; and
- *Implementing* adaptation solutions where the business case warrants it (Pasteris, 2010).

In the U.S. Department of Transportation (DOT) guide for climate change adaptation within the greater transportation system's management, operations, and maintenance, it is recognized that "with climate change comes uncertainty, be it in a greater variability of expected events or unexpected extreme weather and by not understanding the risk or not assessing the vulnerability of their operations, agencies can be caught off-guard by an unexpected event leading to significantly degraded capabilities when they are most needed" (US. Department of Transportation, 2015, p. 8). The guide proposes a framework for short-term, mid-term, and long-term adaptation planning that includes data-driven risk assessment, continued collaborative dialogue, and brainstorming across stakeholders (US. Department of Transportation, 2015).

By looking at longer term climate projections (out to 2100), we take a step towards long-term adaptation planning, which generally involves studying potential future scenarios, considering potential effects of those scenarios, and designing adaptation measures fit for purpose. Pasteris (2010) defines adaptation as a process through which societies make themselves better able to cope with an uncertain future. But effective adaptation is more than coping; it is also managing better in the face of multiple unpredictabilities.

Risk assessments requirements are one common management mechanism across initiatives set out by governing bodies including the Pipeline and Hazardous Material Safety Administration (PHMSA), the National Transportation Safety Board, and the United States Coast Guard (Transportation Research Board & National Academies of Sciences, 2017). These government bodies were, amongst others, identified as being in charge of ensuring the safety of pipeline, rail, and waterway hazardous liquid and gas transportation modes. The National Academies of Science, Engineering, and Medicine analyzed these transportation modes for repeating patterns of failure and made recommendations for improvements (Transportation Research Board & National Academies of Sciences, 2017). The National Academies' analysis did not, however, look specifically at impacts of extreme weather-induced events on the relevant infrastructure.

In carrying out assessments and analyses related to climate change impacts on infrastructures, TFS stakeholders in the state are subject to a number of regulations and guidelines set by the state and local governments. A necessarily brief and selective summary of these include:

- California Assembly Bill (AB) 2516: Sea level rise planning: database (Gordon, 2014). This bill required:
“On or before January 1, 2016, the Natural Resources Agency, in collaboration with the Ocean Protection Council, to create, update biannually, and post on an Internet Web site a Planning for Sea Level Rise Database describing steps being taken throughout the state to prepare for, and adapt to, sea level rise. The bill would require various public agencies and private entities to provide to the agency, by July 1, 2015, and, beginning January 1, 2016, on a biannual basis thereafter, sea level rise planning information, as defined, that is under the control or jurisdiction of the public agencies or private entities.”
- Executive Order B-30-15, signed by California Governor Brown, requires State agencies to incorporate climate change impacts into planning and infrastructure. The Order (Office of Governor Edmund G. Brown, Jr., 2015) articulates that:
“Climate change poses an ever-growing threat to the well-being, public health, natural resources, economy, and the environment of California, including loss of snowpack, drought, sea level rise, more frequent and intense wildfires, heat waves, more severe smog, and harm to natural and working lands, and these effects are already being felt in the state... Taking climate change into account in planning and decision making will help the state make more informed decisions and avoid high costs in the future.”
- The San Francisco Sea Level Rise Action Plan (City and County of San Francisco, 2016), which states:
“The Plan, led by San Francisco Planning and San Francisco Public Works, defines an overarching vision and set of objectives for future sea level rise and coastal flooding planning and mitigation in San Francisco. Proactive, thoughtful adaptation planning will allow San Francisco to minimize risks and meet the challenges posed by rising seas. The innovation, creativity, and inclusivity that have always inspired growth and development in San Francisco will support both sea level rise adaptation and continued growth as a leading global city.”

For example, the California Department of Transportation (Caltrans) has started carrying out vulnerability assessments that outline climate change effects, identify impacts, and present details on the technical processes that are employed to identify climate impacts. The first summary and technical report has been published for District 4, which serves Sonoma, Napa, Solano, Marin, San Francisco, Contra Costa, Alameda, San Mateo, and Santa Clara counties in Northern California (California Department of Transportation, 2018). The assessments take into account sea level rise, storm surge, wildfire, and a combination of these weather events.

In carrying out assessments and analyses related to climate change impacts on infrastructures, TFS stakeholders are faced with obstacles to producing effective, long-term adaptation planning. In discussions with stakeholders and in analyzing the TFS, the following obstacles are

highlighted since they also pose real-time challenges to operations and risk management that are likely to persist into the foreseeable future:

- Critical-goods supply chains within the TFS are very complex: complex to design, complex to operate, and complex to analyze. This is because they are large in size, involve dynamic time-variant behavior, have heterogeneity across end-users, and are extensively interconnected with other critical facilities outside the sector. The chief feature of socio-technical complexity is surprise and the inability to predict with the accuracy required (e.g. Demchak, 1991), which make long-term strategic planning all the more difficult for TFS stakeholders.
- There is an ongoing replenishment of infrastructure within the entire TFS over time as assets need replacement, technologies are improved, and upgrades are warranted. This makes it difficult to project long-term system failures and develop long-term strategic plans for the sector as a whole.
- The number of scenario combinations and permutations for analysis increase as various exposure threats are modeled and projected. These in turn can have a cascade effect and negatively impact TFS assets. For example, wildfires can destroy hillside vegetation, leading to landslides and flooding during subsequent severe rainstorms.
- Finally, assessment of the interconnected parts of the TFS that are necessary to support movement of products across the supply chain demands the inclusion of a temporal dimension extending beyond many of its constituent's planning horizons. This adds to the difficulty of long term planning at the sector level.

Constant vigilance is required by both policymakers and individual TFS stakeholders in order to better manage and improve the TFS as a whole. As such, it is important to both groups to produce flooding and wildfire projections for temporal periods that are of relevance to them.

1.5 Modeling Extreme Weather Events

In order to estimate the potential exposure of TFS assets to extreme weather-induced coastal flooding, inland flooding, and wildfire under climate change, we use numerous climate change scenarios and spatially model and analyze flooding and wildfire events across time and by periods under the conditions prescribed by those scenarios. We then evaluate the coincidence of flooding and wildfire with our geospatial datasets of TFS assets to estimate their exposure to these hazards. We model and analyze both flooding and wildfire exposure of TFS asset statewide at coarse spatial resolution then identify specific exposed areas with concentrations of TFS assets or areas of particular interest to the stakeholders and model the flooding and wildfire exposure of TFS assets in those areas at a fine spatial resolution.

1.5.1 Climate Change Scenarios

We define climate change scenarios using combinations of 1) representative concentration pathways (RCP) scenarios; 2) General Circulation Models (GCMs); and 3) probabilistic sea level rise (SLR) for coastal flooding, land use land cover (LULC) projections for wildfire, or no additional component (for inland flooding). These scenarios cannot predict the future, but rather are intended to illustrate key uncertainties so that the subsequent decisions made in light of them can be more robust (see Moss et al., 2010).

RCPs are scenarios of future greenhouse gas (GHG) concentration in the atmosphere, indicating possible futures of global climate that serve as a fundamental layer in our scenario construction. Our modeling is based on RCP 4.5 and RCP 8.5 (out of a set of four adopted by the Intergovernmental Panel on Climate Change - IPCC). The Fourth Assessment recommends these two RCP scenarios to its research teams. Together the RCPs represent a wide spectrum of future climate, with RCP 8.5 portraying a high GHG concentration scenario and minimal mitigation and RCP 4.5 representing a mitigation heavy scenario with lower GHG concentrations (relative to RCP 8.5).

The second component of our scenarios is the GCMs. They are used in conjunction with RCPs to project specific climate variables, such as precipitation and temperature, in future climate. This study uses the four GCMs selected by the Fourth Assessment: HadGEM2-ES (warm-dry), CNRM-CM5 (cool-wet), CanESM2 (average), and MIROC5 (complementary), as they cover a broad range of climate model projections on future climate for California.

The third component in our scenarios depends on whether flooding or wildfire is being analyzed. In coastal flooding modeling, SLR values are projected probabilistically by sampling time-dependent probability distributions of five primary global SLR components (Cayan et al., 2016). The Fourth Assessment recommends research teams examine the 50th, 95th, and 99.9th percentile probabilistic SLR values. In statewide wildfire modeling, Westerling (2018) used LULC projections made by Sleeter, Wilson, Sharygin, & Sherba (2017) as one model input. Westerling also used the central and low scenarios in Sleeter’s LULC projections (Sleeter et al. include ten Monte Carlo simulations for each scenario to account for stochastic nature of LULC change).

We obtain our scenarios (**Table 1**) for flooding and wildfire modeling by combining the components above. For coastal flooding models, we identify 24 scenarios combining RCP 4.5 and 8.5, four GCMs, and three probabilistic SLR values. For inland flooding models, we identify eight scenarios incorporating the two core RCPs and four GCMs. For wildfire models, Westerling’s dataset identified 240 scenarios from the two core RCPs, four GCMs, and three LULC scenarios (with 10 stochastic variations each). For more detailed information regarding the scenarios, please refer to section B.1 in Appendix B.

Table 1. Scenarios assessed in this study and their components

Hazard		Components of the scenarios			Number of scenarios
		GHG concentration scenarios	Climate models and descriptions	Additional scenario components	
Flooding	Coastal flooding	RCP 4.5 - moderate GHG concentration with some climate change interventions;	HadGEM2-ES: warm/dry;	3 probabilistic SLR values	24
	Inland flooding		CNRM-CM5: cool/wet;	-	8
Wildfire		RCP 8.5 – high GHG concentration without climate change interventions	CanESM2: average; MIROC5: complementary	3 LULC scenarios, each with 10 stochastic variations	240

Description of a climate model is given in terms of the projected climate pattern of this model relative to other candidate models. The warm/dry model tends to project hot temperature and less precipitation, which is contrary to

the cool/wet model. Average model tends to give projection values close to the average of the candidate models. Complementary model gives projections that are most different from the previous three models.

1.5.2 Flood Modeling Methods Overview

Our flood modeling looks at both coastal flooding caused by SLR and storm surge as well as inland flooding due to rainfall under the various climate change scenarios identified in the preceding section.

To assess coastal flooding exposure, we initially execute a statewide model at a coarse spatial resolution of 50 m (164 ft). We employ a 3Di hydrodynamic model (Stelling, 2012a) to model inundated areas during extremely high sea level events (i.e. a 72-hour storm event with the highest sea level of a given climate scenario and bi-decadal period). Our statewide model assesses coastal flooding exposure under all 24 flooding scenarios in **Table 1** over five 20-year periods between 2000 and 2100 (i.e. 2000-2020, 2020-2040, 2040-2060, 2060-2080, 2080-2100). Again, these horizons can be used for risk management, investment, planning, depreciation, or other purposes. We then conduct local scale modeling at a fine spatial resolution of 5 m (16.4 ft) only in selected areas because at this resolution it takes much more computing power to run our analysis. We select these areas based on flooding exposure in the statewide model, coincident concentration of TFS assets, and advice from TFS stakeholders. We then use the 3Di hydrodynamic model to simulate both coastal and inland flooding at local scales.

Our local scale models focus on the 2020-2040 period (which TFS stakeholders express great interest in) and the 2080-2100 period (to show the exposure near the end of the century). The local models also focus on high, medium, and low estimates of the high sea level events (for coastal flooding) and the maximum daily rainfall intensity during a bi-decadal period (for inland flooding), to show the range and center of flooding exposures under a range of climate scenarios. An overview of the flood modeling is shown in **Table 2**.

1.5.3 Wildfire Modeling Methods Overview

We analyze statistical and process-based model outputs to determine which TFS assets are likely to face potentially hazardous wildfire events and behaviors during current and future periods of interest. Similar to flooding, we analyze wildfire exposure at both a statewide and a local scale. We obtain statewide projection data for wildfire events from work completed by Westerling (2018). Westerling's wildfire projections are generated from an empirical modeling framework that relied upon past empirical data to estimate large (> 400 hectares (ha); 1.54 square miles) fire presence, numbers of fires, and area burned at 16th degree (approximately 3.85-square miles) spatial resolution for all months between 1953 and 2100. Westerling's predictive modeling routine is initialized using input data from each of the 240 wildfire scenarios described **Table 1**.

Our TFS exposure assessment takes estimates of area burned from all scenarios modeled by Westerling into account when evaluating regional and sub-regional changes in California wildfire patterns over the current century and between the aforementioned specific 20 year-long periods for investment, risk management, or other entity-specific purposes. To assess exposure of specific TFS assets and organizations to wildfire at local scales, we model wildfire behavior, including flame length, rate of spread, and fire intensity, based on weather, fuel, and topographic conditions using a fire behavior model, FlamMap (Finney, 2006).

TFS stakeholders express great interest in present-day and nearer-term levels of exposure. Fortunately, we are able to model local scale exposure to wildfire under both present and future weather conditions. Considering stakeholder interest, we focus our local scale modeling efforts on modeling wildfire behaviors using extreme weather conditions recorded during recent large or notable fires. However, in order to assess changes in wildfire hazard driven by changes in weather extremes, we also model wildfire behavior using weather derived from future climate projections. An overview of the wildfire modeling is shown in **Table 2**.

Table 2. Overview of the models in this study, highlighting the hazards of interest, corresponding spatial scales of the models, climate-related drivers of the hazard, and results for hazard exposure.

Hazard		Spatial scales and resolution	Climate-related drivers of hazard	Metrics for hazard exposure	Model
Flooding	Coastal flooding	Statewide (50 m)	Projected sea level rise and storm surge during a 72-hour window with the highest sea level during a 20-year period.	50 m maps of maximum flooding depths and extents	3Di hydrodynamic model (Stelling, 2012a)
		Local scale (5 m)		5 m maps of maximum flooding depths and extents	3Di hydrodynamic model
	Inland flooding	Local scale (5 m)	Projected rainfall with the highest daily intensity of a 20-year period.	5 m maps of maximum flooding depths and extents	3Di hydrodynamic model
Wildfire	Large Wildfire Events	Statewide (6.2 km)	Projected climate variables such as precipitation, temperature, and relative humidity	16 th degree maps of burned area	Empirical estimates by Westerling (forthcoming)
	Wildfire Behavior	Local scale (5 m)	Projected and present-day fuel moisture, relative humidity, temperature, cloud cover, wind speed and direction, in historical extreme fires and projected climate	5 m maps of flame length, rate of spread, and fire intensity	FlamMap fire behavior model (Finney, 2006)

1.6 Stakeholder Driven Vulnerability Assessment

After modeling the exposure of TFS assets to extreme flooding and wildfire events under climate change, we engage collectively with TFS stakeholders to document their response to our initial modeling outputs. We discuss their assessment of the exposure of TFS assets modeled under the extreme weather events and in some cases refine the modeling results in light of their advice. In addition, we ask stakeholders to discuss the added value of our modeling outputs and the modeling process in general in the development of short- and long-term strategic planning.

As part of this interaction, we establish a Technical Advisory Committee (TAC), consisting of representatives of industry stakeholders that own and operate key TFS assets (labeled *TFS core*), representatives of organizations that provide services on which the TFS core organizations rely heavily (labeled *TFS dependent*), and representatives of groups that regulate and or research TFS

core organizations (labeled *TFS Knowledgeable*). We present preliminary plans and results to this TAC to ensure that the study is highly-relevant and includes as many types of stakeholders and assets as possible.

We organize workshops to collect information from the public and TFS stakeholders to improve our understanding of the assets in the TFS network, its internal and external interconnections, and the areas stakeholders are concerned about from an extreme weather event exposure perspective. In addition to the workshops, we hold discussions with various groups of TFS stakeholders to gain more detailed insight into their TFS assets, potential vulnerabilities to extreme weather events, interdependencies within the sector and with other sectors, and potential strategic plans already in place or being developed.

Last but not least, a key part of our analysis examines possible impacts of extreme weather events to the pipeline distribution system of refined fuels, a sector Kinder Morgan, Inc. dominates. Kinder Morgan, Inc. is the only common carrier of petroleum product pipelines in the state and transports the majority of fuels through its system each day. We enter into a Non-Disclosure Agreement and hold in-depth discussions with Kinder Morgan, Inc. and complete specific exposure modeling focusing on their assets and flows within the state. The centrality of Kinder Morgan, Inc.'s assets underscores the importance of knowing more about the complexities and the vulnerabilities of its infrastructure and operations, especially given that some of their assets are considered possible chokepoints in the State's TFS.

1.7 Innovative Approach

Much climate change research has been undertaken looking at the planet as a whole. This is expected given the many GCMs and the range of RCPs based on possible changes in future anthropogenic greenhouse gas emissions. Although researchers have downscaled the planetary projections to predict California's future climate (Cayan et al., 2016; D. W. Pierce, Cayan, & Thrasher, 2014), the spatial scale often remains difficult for stakeholders to embrace beyond real-time and the nearer-term.

With this in mind, and after meeting with our TAC, we embark on a multi-scale modeling strategy across various spatial scales. We began with a statewide approach, modeling vast regions and analyzing current and future wildfire and flooding events. We combine our model results with TFS infrastructure identifying regions of exposure. Although these results stimulate some discussion amongst stakeholders, it is apparent that the coarse spatial scale is insufficient for stakeholders to identify risk to their individual assets.

We overcome this by gathering high resolution data, some of which are at very fine spatial scales (1 m or ~ 3 ft), and refine our models at a 5 m (~16 ft) spatial resolution. For flooding we included all objects or built structures with the topography in our model, using LiDAR data to estimate their heights above the datum (above the ground level). For wildfires, we include built structures and vegetation patches, once again using LiDAR data to estimate the heights. In addition, we employ 1 m (~ 3 ft) multi-spectral imagery to identify vegetation fuel types.

The intersection of these detailed spatial resolution models with TFS infrastructure greatly enhances the exposure estimates of individual assets. Moreover, the stakeholders embrace the results and become more actively involved in the discussion of vulnerability and resilience. This leads to further discussions with individual TFS stakeholders.

Finally, our strategy to model different periods presented by flooding and wildfires enabled stakeholders to focus on both near-term and long-term strategic planning, and rapid, emergency response.

1.8 Structure of Report

The remainder of the report describes in detail our methods, analysis, and conclusions. Chapter 2 describes our concept of the TFS in California, its key assets and their intraconnectivity. Chapter 3 identifies our spatial temporal modeling of coastal flooding, inland flooding, and wildfire through time under numerous climate change scenarios, and presents the results of our exposure analyses. Chapter 4 describes our engagement with TFS stakeholder to understand the complex TFS and the implications of our modeling results. Finally, Chapter 5 presents a summary of our results and our conclusions.

2: Transportation Fuel Sector - Assets, Operation and Organization

To understand the possible exposure of TFS assets to wildfire and flooding, a necessary first step is to identify and then frame the assets that are necessary for the reliable supply and distribution of transportation fuels in California. We conceptualize the TFS in the form of a schematic and explain the key assets, conceptualized as nodes and links in a network, their multimodal connections, and their various dependencies on each other. Finally, we map the georectified TFS assets within a Geographic Information System (GIS) of California.

To illustrate the intraconnections between critical assets within the TFS and other indispensable infrastructure networks within the state, an example using a refinery is detailed. The organizational network and its institutional framework are briefly examined to give an idea of the inter- and intra-organizational relations that are formed to reliably operate and manage transportation fuel supply and distribution. This examination also provides a context for the laws, regulations, procedures, and informal conventions, customs, and norms which shape the economic market and behavior of the TFS organizations.

To our knowledge, this chapter's schematic is the first to consolidate into one conceptual model the key elements of the State's TFS as currently represented in the literature and understood by sector stakeholders.

2.1 Conceptualizing the TFS – Definitions and System Boundaries

Because an estimated 94% of California's transportation fuel consumption is sourced from crude oil in 2014 (Lawrence Livermore National Laboratory, 2014), our conceptual model of the TFS focuses on a supply chain strongly related to the oil industry. The focus is on the supply and demand of crude oil-derived fuels – gasoline, diesel, propane, jet fuel, kerosene, and heavy oil – that are used in the state for transportation via vehicles, aviation and, to a smaller extent, marine vessels. There are a great variety of alternative transportation fuel sources in California, such as biodiesel, ethanol, natural gas, electricity, and hydrogen. Together these constitute approximately 6% of the fuel consumed in California and are not directly addressed in this report. A parallel analysis of the exposure of hydrogen fuel stations to flooding and wildfire is available in Appendix F.

When conceptualizing the TFS, the oil industry is considered and must be recognized as one of the most complex supply chain systems (Kazemi & Szmerekovsky, 2015). It is conventionally subdivided into three core operational/business segments: upstream, midstream, and downstream (Cragg, Burton, Feinberg, & Schaik, 2011; Herkenhoff, 2014). However, there are acknowledged operational overlaps between and among what operators refer to as the midstream and downstream and the midstream and upstream segments. This overlap depends on an organization's business profile. They might specialize in one of these segments or they might be an integrated oil company operating through the entirety of the supply chain system.

Since segment overlap is not always clear, we refrain from referring to the parts of the TFS as upstream, midstream, and downstream segments. Instead, we divide the operational processes of the fuels (from production, transportation, refining to distribution) as separate subsystems.

By representing the operational processes in a supply chain, we show the vertical integration between the steps and processes needed to achieve various transportation fuel products from crude oil. We then expand the supply chain schematic to include the assets needed to move, produce, and store crude oil and fuel products. This offers insight to which physical assets need to be mapped geospatially to gain a comprehensive overview of the TFS and simulate its exposure to current and projected wildfire and flooding events. The TFS functions as a coherent critical infrastructure when it vertically integrates the operational processes from production through refining to end-use distribution of fuels (Miller, 2009; Rinaldi, Peerenboom, & Kelly, 2001).

The conceptual model of the TFS helps us:

1. Identify geospatial datasets that define TFS assets and the connections between them. These assets and connections are used to build the geospatial network model. This model is then intersected with the wildfire and flooding models to examine the exposure and thus the potential vulnerability of the assets to projected wildfire and flooding; and
2. Communicate our vision of the TFS to stakeholders. The model is used during workshops and discussions to help identify and define important assets and their intraconnections.

2.1.1 TFS Supply Chain Overview

Our conceptual model is built after energy supply chain graphs of the oil sector commonly used to explain the diversity and complexity of the critical systems. These graphs seek to visualize key elements of supply and demand and the connections between and among them, as demonstrated in examples given by the American Petroleum Institute guidebook (American Petroleum Institute, 2016) and the EIA on weather disruptive events to the fuel supply (U.S. Energy Information Administration, 2013).

At the conceptual model's foundation lie the assets necessary in the state for the reliable supply and distribution of transportation fuels. This means we represent the essential infrastructures that transport the crude oil to the refineries (pre-refinery) and then transport the produced fuels from the refineries to the demand destinations (post-refinery). Most simply, this is represented in **Figure 1** where we conceptualize the pre- and post-refinery processes and show five different commodities subsystems (crude oil, common vehicle fuel products, airport fuel products, maritime fuel products, and gasoil). Literature pertaining to oil supply chain graphs shows that

such integrated production-distribution structure is commonly adopted and adapted for planning and optimization (Sahebi, Nickel, & Ashayeri, 2014).

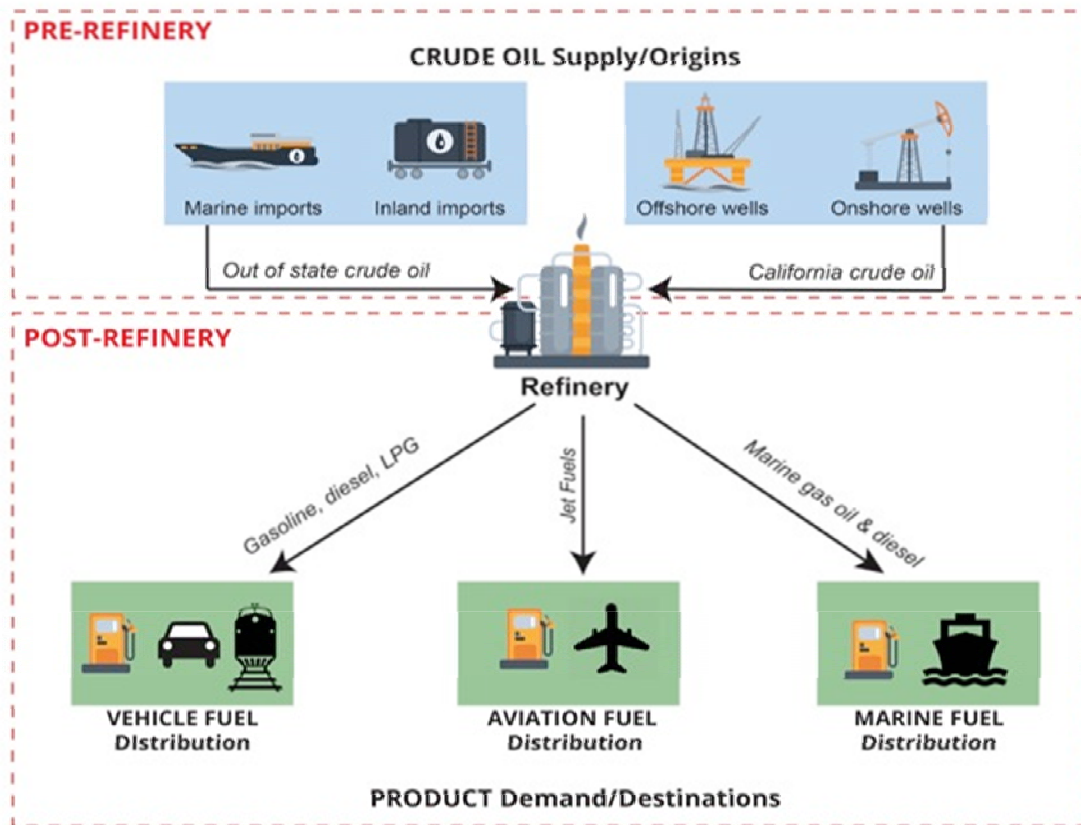

Figure 1. TFS supply-demand chain overview

2.1.1.1 Pre-Refinery: Crude Oil Supply

The crude oil feedstock input into the crude oil subsystem is sourced from within the state or out-of-state. In 2017, out-of-state sources accounted for 69% of the crude supply to the State’s refineries; 12% from Alaska and 57% from foreign sources such as the Middle East and South American countries (California Energy Commission, 2017c). In that same year Californian oil fields produced 31% of the crude supply sourced to the State’s refineries (California Energy Commission, 2017c).

2.1.1.2 Refineries

Refineries are key TFS assets since they are the central nodes in the fuel supply-demand chain system; they are the ultimate demand nodes for crude oil feedstock and the primary supply

origin for fuel products. At these complex industrial facilities raw crude oil is converted by a range of processes into usable fuel products (Hilyard, 2012).

California's largest refineries are capable of processing a variety of crude oil types. Fifteen out of eighteen refineries are configured to produce cleaner fuels, including California reformulated motor gasoline and low-sulfur diesel (U.S. Energy Information Administration, 2017c). During 2016, California processed 1.612 million barrels per day of crude oil and produced refined products including California reformulated gasoline (43%) and diesel (13 %); commercial jet fuel (13%); conventional gasoline (5%); Environmental Protection Agency diesel (4%); small amounts of military jet fuel and other diesel; and other petroleum products (20%) (Schremp, 2017a).

2.1.1.3 Post-Refinery: Fuel Product Demand

The state fuel production for 2017 is approximately divided into 61% for motor gasoline, 20% for distillate fuels (diesel fuels, fuel oil), 16% for aviation fuels, and 3% for residual fuels (California Energy Commission, 2017c). In our TFS conceptual model, motor gasoline and distillate fuels are found in the vehicle fuel subsystem; distillate fuels as well as residual fuels are in the marine fuel subsystem; and the aviation fuels are what distinguish the aviation fuel subsystem.

Vehicle Fuel Subsystem

Products such as gasoline or diesel (distillate) leave the refineries and enter the vehicle fuel subsystem. They represent, on average, 80% of the State's fuel production. Their destinations are wholesale and retail gas stations, which sell the fuel to end users of land vehicles, water-borne vehicles, and small engine tools.

Ethanol is added to produce California reformulated fuels for the vehicle fuel subsystem and is therefore integrated as a commodity in this subsystem. Ethanol constitutes 10% of the final gasoline and diesel products. There are four ethanol plants in California (U.S. Energy Information Administration, 2017), but a large portion of this commodity comes mainly by railway from the U.S. Midwest and a smaller portion by tanker vessels. The ethanol is blended with the gasoline and diesel at the refinery or intermediary terminals.

Aviation Fuel Subsystem

Representing around 16% of the State's fuel production, aviation fuels, such as kerosene-type and naphtha-type jet fuels, are transported from refineries to civilian and military airports in the state. The highest demand is for commercial aviation, kerosene-type fuels commonly known as Jet-A and Jet A-1 produced to an international standard specification (Davidson, Newes, Schwab, & Vimmerstedt, 2014). Aviation gasoline is also part of this commodity subset, but it is used for smaller aircraft and corresponds to less than 1% of the aviation fuel demand (Davidson et al., 2014).

Military jet fuels differ from commercial jet fuels and are commonly referred to as "jet propeller" with a variety of mixes used for different engine turbines. Usually they flash at a higher temperature and have specific additives. Mostly, the additives are added at the military marine terminals or at the airport fuel terminals, but smaller quantities are also added at the refinery.

Marine Fuel Subsystem

There are two types of marine fuels: the lighter distillate fuels and the heavier residual fuels or marine gasoil (Vermeire, 2012), which represent less than 5% of the State's fuel production. Small portions of the refined products are marine gasoil, also known as heavy oil or bunker fuel. It is considered as the heaviest commercial fuel that can be refined from crude oil and is made specifically for tanker barges or tanker vessels.

2.1.2 Conceptual Model

While the above **Figure 1** shows the general processes in the supply chain, it does not show the assets that physically make up the subsystems and enable the flow of crude oil and the fuel products (commodities) through the subsystems. We therefore expand the model to include nodes and links to show the network structure of the supply, production, and distribution of transportation fuels in California. This is reflected in the **Figure 2** schematic used throughout the rest of this report).

Transportation Fuel Sector in California - Conceptual Model

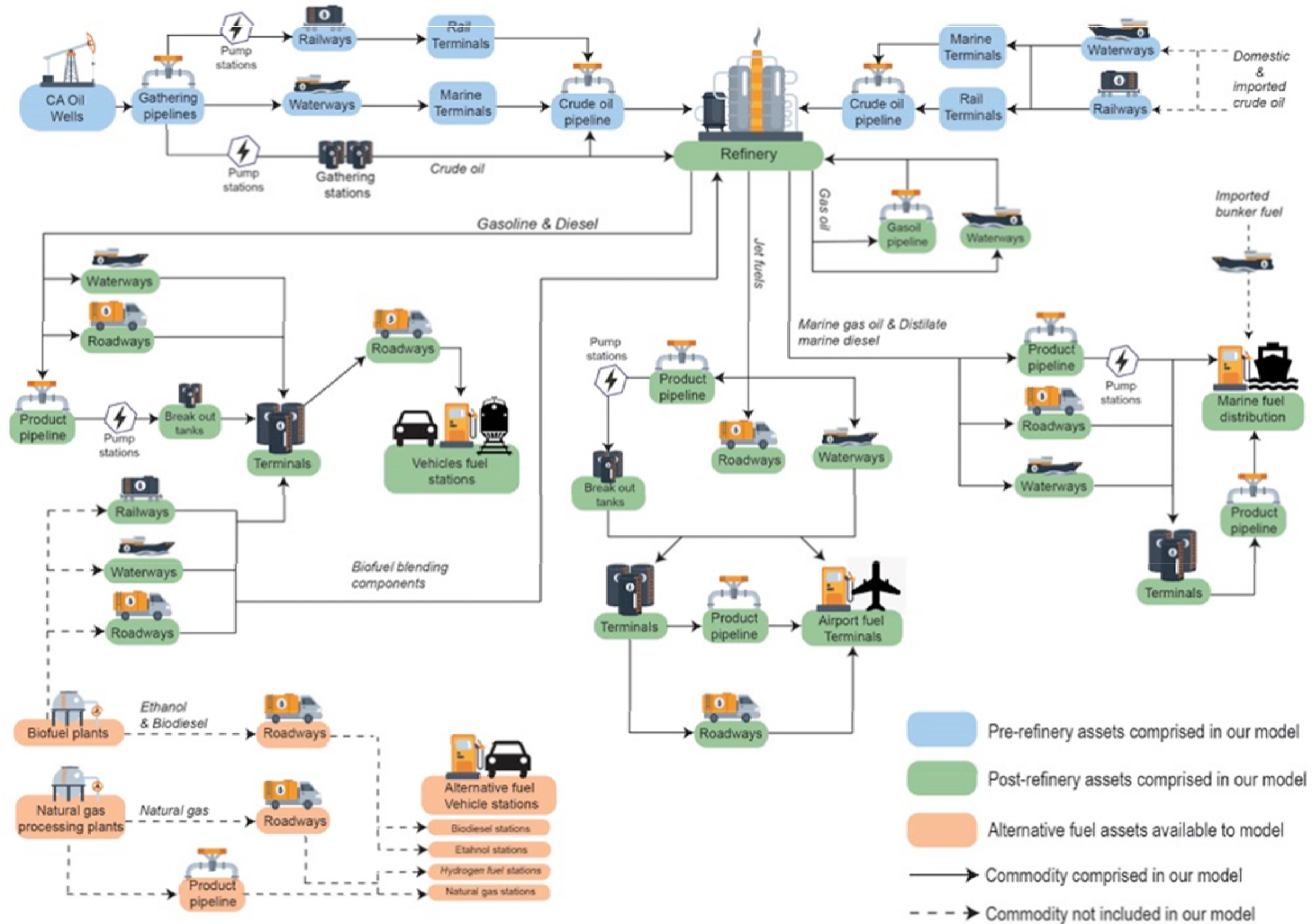

Figure 2. California's Transportation Fuel Sector conceptual model

Our starting point is a conceptual model that enables any reader to follow an oil molecule through the various TFS assets as it, for example, leaves a California oil field through crude oil gathering pipelines to gathering stations, and then moves from those stations to a refinery through a crude oil pipeline. Similarly, we can follow a hypothetical imported oil molecule as it moves through marine and rail terminals and through crude oil pipelines to one of the California refineries.

The conceptual model follows a network structure containing nodes and links. *Nodes* are the assets where commodities are processed, transferred, and/or stored. *Links* are key transportation assets through which commodities are moved. They include waterways, railroads and roads over which tanker vessels, tank cars and tanker trucks carrying crude oil or fuels move, and pipelines through which crude or fuels flow. In examining the exposure of the assets to wildfire and flooding these nodes and links are generally categorized, as shown in **Table 3**.

Table 3. General TFS assets categorized per node and link

Nodes	Links
Oil Fields / Oil Wells	Pipelines (crude oil and products)
Refineries	Railways
Terminals (including rail)	Waterways
Ports (including marine terminals)	Roadways
Airports	
Vehicle Fuel Stations	

The nodes represent origin, intermediary, and destination nodes. The links represented in the TFS are four essential freight modes: Pipelines, railways, and waterways are usually used for long-haul movement of commodities (**Figure 5**, located at end of the chapter), while roads participate in shorter distribution transit, usually involving the last leg of product deliveries (**Figure 6**, located at the end of the chapter).

2.2 Key Assets

This section describes the function of the key assets shown in the conceptual model (**Figure 2**) in the State’s transportation fuel supply chain for each subsystem. In addition, it describes the location of these assets within the state. The latter is especially important in understanding possible exposure to flooding and wildfire. Most of the State’s refineries are located near waterways and thus could be at risk of exposure to coastal flooding.

A quick look at maps of the TFS assets’ location shows that most of the State’s pre-refinery and refinery assets are located near waterways and exposed to projected coastal flooding (**Figure 7**, **Figure 8**, **Figure 10**, and **Figure 11**, located at the end of the chapter). This quick view shows that links, such as pipelines and railways, are more exposed to projected wildfire since they pass through the State’s wildland areas (**Figure 5**). However, we describe in Chapter 3 that actual exposure depends on the conditions at specific locations.

2.2.1 Assets Found Across Subsystems

Many assets have their functions contained within a single subsystem, while three assets, namely ports, waterways, and terminals, can be found across several subsystems of the pre-

refinery and post-refinery processes. Ports, terminals, and waterways are important because two-thirds of the crude oil processed in California is imported from other states or countries and the majority of crude oil is received at the State's marine facilities (U.S. Energy Information Administration, 2017c). The marine terminals in the ports are designed to accommodate crude oil vessels and petroleum product tankers and most refiners operate a proprietary dock with adjacent storage tanks to hold incoming crude and outgoing petroleum products prior to transfer (Schremp, 2017a).

The marine transportation system is composed of thousands of kilometers of navigable waterways with hundreds of ports as origin and destination nodes. Waterways are the cheapest transportation mode for the movement of bulk petroleum products. The U.S. Army Corps of Engineers is the major governmental agency responsible for the maintenance of the navigable waterways, including channel dredging and control of water flows and channel depths (National Academies of Sciences, Engineering, and Medicine, National Academies of Sciences, Engineering, and Medicine, Studies and Special Programs Division, Transportation Research Board, & National Academies of Sciences, Engineering, and Medicine, 2017). In California, most movement is done through coastal and intra-coastal systems. In California, the most important river system is the Sacramento River, which links San Francisco Bay Area TFS assets to the Stockton TFS assets. Most oil companies lease ships on a charter basis either for a long period of time or on a spot basis. Refineries usually operate a proprietary dock and grant third-party access to pipeline, rail or truck infrastructure (Schremp, 2016b).

Nine major ports are in California. Five serve the San Francisco Bay Area from the south bay to Stockton, four are in southern California between Port Hueneme and San Diego. Two major ports are at Los Angeles and Long Beach, the latter hosts the largest pier, Berth T121. This pier has the deepest berth in the port (23.5 m; 77 ft.) and is designed to accommodate tankers with 50,000 to 265,000 deadweight tonnage (Port of Long Beach, 2017). Ships dock there only during high tide. It is chartered by Andeavor, but also serves other refinery companies and is considered to be the single most important unloading node of crude oil in terms of volume for the state.

Terminals are any location where liquid bulk transportation fuel commodities originate, terminate or are handled in the supply and distribution process. Terminals are typically multi-purpose and are polysemous. Depending on the organization or the TFS commodity subsystem, the same terminal facility might be an intermediate transshipment node, an end node, or an origin node. By way of illustration, port terminal facilities can be considered a crude oil origin node for imported feedstock with transloading equipment to railways. However, the same port might also be a fuel product intermediate storage facility with transshipment from pipelines to ocean-going vessels. That same port may also represent the end node for the marine fuel commodity subsystem. A common characteristic of terminals is that they are collocated with storage tanks, as the process of transloading liquid commodities usually requires a storage component.

As there is no clear single definition of a terminal when comparing definitions from different government energy agencies, it is not possible at this point to identify for official purposes how many of these facilities exist in the State. We consider that a TFS terminal represents an intermediary facility in the fuel supply chain between the origin and destination nodes. Considering the terminal definition described for this project, we have identified approximately 100 facilities, a number consistent with California Energy Commission's (Energy Commission's)

estimates. Roughly half of the State’s terminals are clustered in the San Francisco Bay Area and the Los Angeles (LA)/ Long Beach Area and three quarters are in California’s coastal zones (**Figure 7** and **Figure 8**).

2.2.2 Pre-refinery: Crude Oil Subsystem

The node and link assets that are associated with the crude oil commodity subsystem provide crude oil to the State’s refineries and are summarized in **Table 4**.

Table 4. TFS assets in the crude oil commodity subsystem

Process	Commodity subsystem	Source	Possible Node Assets	Possible Link Assets
Pre-refinery: Crude oil	Crude oil	Out-of-state	Marine Terminals (in ports) Rail terminals	Railways Waterways
		In-state	California oil wells Pipeline pump stations Gathering stations Marine terminals (in ports) Rail terminals Refineries	Crude oil gathering pipelines Railways Waterways Crude oil pipelines

The commodity transfer from the marine and rail terminals to the refineries takes place through crude oil pipelines. According to the latest figures of the National Pipeline Mapping System (NPMS), there are nearly six thousand km of crude oil pipelines in service or idle in California (Pipeline Hazardous Material Safety Administration - PHMSA, 2017). Crude oil pipelines have shipment specifications based on the refineries’ grade needs. There are 36 different crude oil pipeline operators in California; Crimson Pipelines is responsible for nearly 30% of the network, followed by Phillips66, Shell, Chevron, ExxonMobil, and Plains All American, which collectively account for another 10-15% of the network. Thirty-one other companies cover 5% or less of the total crude oil network.

According to the Energy Commission’s monthly receipts of crude oil by source, one-third of the crude oil processed in California comes from in-state oil wells. The main crude oil pipelines receive crude oils of distinct qualities along their routes, and they are either mixed or segregated into different delivery batches. Refineries are sometimes designed to receive a specific quality of crude oil. Accordingly, there are tests at the production level to assess basic sediment and water in the oil as well as other physical and chemical characteristics to ensure it conforms with the refinery contract’s specifications. This adds to the complexity of the supply chain, even at the pre-refinery process stage where crude oil is the sole commodity type.

Pipelines have their own key infrastructures such as pump and valve stations that maintain desired pressure levels and flow rates. Pump station locations vary due to topography, pipe diameter, and operating pressure, but roughly they are placed in between 20-100 miles of pipeline intervals (National Academies of Sciences, Engineering, and Medicine et al., 2017).

Crude oil sourced from within the State relies on oil fields mainly located in Kern County, which produces over 72% of the State’s total crude oil (**Figure 3**). The assets associated with these fields include: oil wells (**Figure 9**); oil lift structures (pump jacks); gathering stations or

crude oil stock tanks (nodes); and gathering lines (links). After the oil surfaces, it is gathered by a web of short-distance gathering lines to intermediary gathering stations before entering the main crude oil pipeline systems that deliver the feedstock to their ultimate destination: refineries. The network of crude oil pipelines connects the fields to three primary refining centers; the Los Angeles area, the San Francisco Bay Area and the Central Valley (U.S. Energy Information Administration, 2017c).

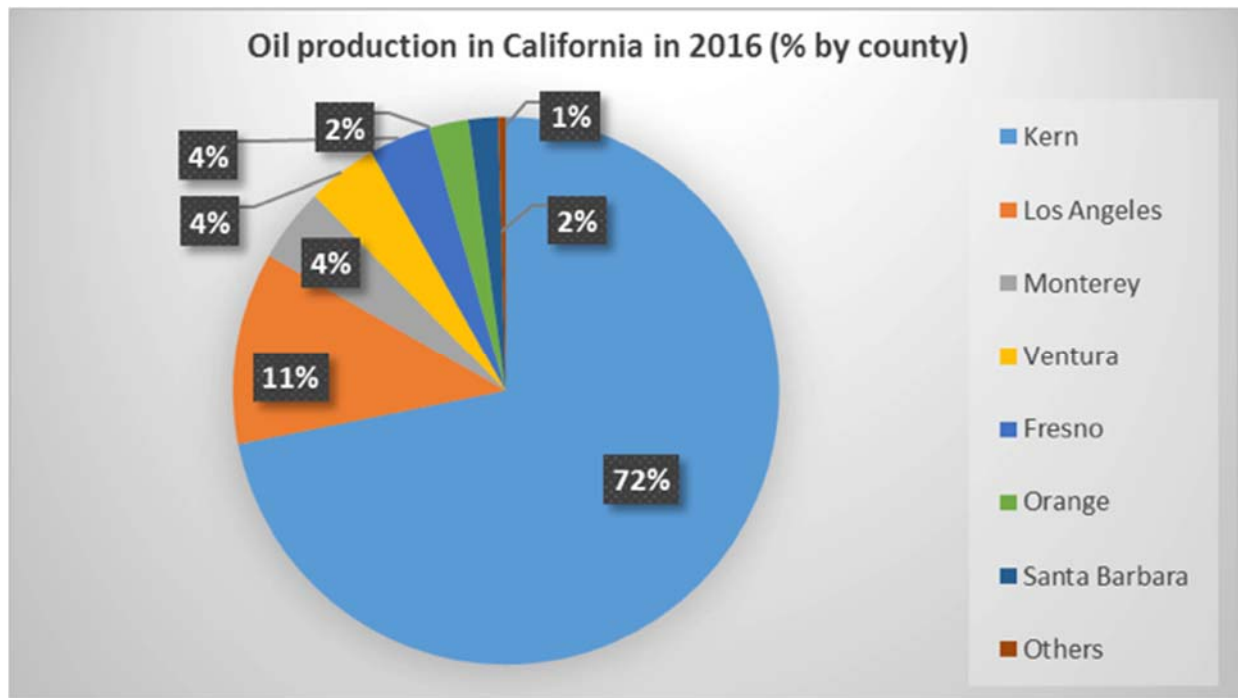

Data sourced from Division of Oil, Gas, and Geothermal Resources (2016)

Figure 3. In-state crude oil origins.

Railways cover a minor fraction of the State’s crude oil transportation market compared to waterways. A fraction (0.59%) of the total crude oil imported into the state in 2016 came via railway (California Energy Commission, 2016b). Officially, there are six crude oil rail terminals in California, four concentrated in LA/ Long Beach Area, one in Bakersfield, and another in Richmond according to the EIA 2014 database. Following our discussions with TFS stakeholders (Chapter 4 and Appendix E), it is clarified that some of these terminals are no longer handling crude oil commodities but are still important to the TFS geospatial network as they handle other vital inputs to refineries such as ethanol and other products (see Chapter 2 section 3). The two main rail operators in the State transporting crude oil and vital inputs for the refining process are Union Pacific Railroad (UP) and Burlington Northern Santa Fe Railways (BNSF).

Despite the small fraction of crude oil transported via railway, rail freight transportation carries the majority of ethanol. UP and BNSF own and operate most of the ethanol freight lines west of Mississippi River and in California (National Academies of Sciences, Engineering, and Medicine et al., 2017). In California, UP provides roughly 75% and BNSF 25% of long-distance freight transportation through Class I tracks. These organizations then rely on a series of local tracks

belonging to smaller companies or the refineries for the service's last leg on Class II and III tracks. Class I tracks are designed to operate line-haul trains that contain 70 tank cars or more (Rodrigue, Comtois, & Slack, 2017). The most common tank car used to move hazardous liquids in the US is the DOT-111 with a capacity of approximately 30,000 gallons. Once a train has reached a rail terminal it can take up to one week to fully unload. Carloads of crude oil are a minor component of the rail traffic compared to ethanol. The principal supply origins of ethanol to the state are from the Midwest (Perez, 2005). There are a few train-capable destination terminals that transload ethanol received by rail in California, mostly located near the San Francisco Bay Area, Bakersfield and Los Angeles refineries. Other functions of railways in the TFS system are transporting vital inputs such as compressed liquified petroleum gas (LPG), and sulfuric acid, to and from refineries (Schremp, 2014).

2.2.3 Refinery Assets

For this research, the many different assets (nodes and links) that make up a refinery facility, such as chemical engineering unit processes, are grouped under one node - the refinery- when they are spatially located close to each other.

Since most of the crude oil inputs to California refineries are off-loaded by ocean-going vessels, 15 out of 18 refineries in the State are located near waterways (**Figure 10**). In northern California, five facilities are located between Richmond, Benicia, and Martinez in the San Francisco Bay Area (**Figure 11**); in Southern California nine refineries are in the Los Angeles/ Long Beach Area. There is one refinery in Santa Maria, and three facilities are located inland, in Bakersfield.

Some of the State's refinery facilities process crude oil into a partially refined product (referred to as gasoil), which is sent to another refinery facility for final processing into consumable fuel products (shown as a loop in the supply chain, **Figure 2**). Distinguishing these refineries are important for understanding the counting process of this TFS asset throughout the report (Appendix A)

Refineries have long life cycles, which means there is a tradition of investing and upgrading existing facilities rather than constructing new ones (Carlson, Goldman, & Dahl, 2015). Because of permitting issues, low profit margins, and competitive markets, it has been judged improbable that new refinery construction will proceed in the country (Hilyard, 2012). In California, between 1985 and 1995, ten refineries were closed (California Energy Commission, 2016a).

Ten different organizations own and operate refineries in California. In 2016, Tesoro (now Andeavor) and Chevron were leaders in refining capacity in California, with a combined operable capacity for atmospheric crude distillation exceeding 510,000 barrels per calendar day, followed by Phillips 66 and Valero (U.S. Energy Information Administration, 2017a).

2.2.4 Post-refinery: Fuel Commodity Assets

The assets that are associated with the three fuel subsystems to get the fuel products from the State's refineries to the end consumers are summarized in **Table 5**.

Table 5. TFS assets per fuel commodity subsystem

Process	Commodity subsystems	Possible Nodes	Possible Links
Post-refinery	Vehicle fuel	Vehicle fuel stations Terminals Break out tanks Pumping stations Refineries	Product pipelines Waterways Roadways
	Aviation fuel	Airports (fuel terminals) Terminals Break out tanks Pumping stations Refineries	Product pipelines Waterways Roadways
	Marine fuel	Ports (Marine fuel distribution nodes) Terminals Pumping stations Refineries	Product pipelines Waterways Roadways
	Gasoil	Refineries	Gasoil pipelines

While the nodes within these fuel commodity subsystems somewhat differ (and are described below), the links in all four subsystems include pipelines. The movement of fuel products in California relies largely on pipelines. This key transportation infrastructure is considered as the most specialized mode for liquid fuels movement and the most cost-efficient (Miesner & Leffler, 2006). Finished products (fuels) and crude oil pipeline networks are not interchangeable and mostly have inflexible flow directions. There are some pipeline segments exclusively for specific fuel types; but in general, the fuels are transported in batches of different products through pipelines to reach the terminals. Like crude pipelines, product pipelines have their own key infrastructures such as pump and valve stations that maintain desired pressure levels and flow rates (National Academies of Sciences, Engineering, and Medicine et al., 2017).

Kinder Morgan, Inc. operates over 60% of the product pipeline network, followed by Chevron, Shell, and ExxonMobil, which operate between 5-10% each. Phillip66, Andeavor, and the Department of Defense each operate between 1-5% of the product pipeline network. Another two-dozen pipeline product carriers each operates 1% or less of the product pipeline network in California. One of the key distinguishing features of the CA TFS is that the State's northern and southern product pipeline networks are not connected.

The last transect of the product distribution is usually the road network. Trucking companies operate in different areas of the state to move the finished products from intermediary distribution terminals to the consumer. According to the CARB Fuels enforcement program, there are nearly 250 certified motor vehicle fuel distributing companies operating in the State in 2016 and 2017. These trucking companies are to follow DOT, Caltrans, and municipal road restrictions on truck dimension, weight, and hazardous material transportation regulations that define their legal routes. The California Department of Transportation (2016b) legal trucking network identifies approximately 24,000 km (14,913 miles) of roadways where fuel trucks may operate.

The transporting of fuel by road does not compete economically with other modes that are designed for long-haul movements and thus road is limited to shorter distance distributions.

However, road networks are denser than the other TFS modes which translates into higher redundancy and flexibility for the industry in case there is a disruption in any of the long-haul transportation modes described above.

The vehicle fuel stations, airports, and marine fuel distribution nodes in the ports serve as the last point (end node) before the fuel is sold to the end user. Consistent with supply chain theory, the final distribution nodes in California are in more populous regions and are more distributed throughout the territory (**Figure 12**, **Figure 13**, and **Figure 14**). These end nodes have more redundancy compared to the other nodes and thus one single end node is less crucial to the entire TFS.

Vehicle Fuel Commodity Assets

Most (75-85%) of the vehicle fuels (gasoline and diesel) leave the refineries to the terminals by pipelines (Schremp, 2017a), while the remaining gets transported through roadways by tanker trucks or through waterways by tanker vessels and barges. Transit from the terminals to gas stations or retail outlets occurs mainly by tanker trucks. According to the California Retail Fuel Outlet Annual Reporting, there are 10,202 fuel stations that sell gasoline, diesel, and other transportation fuel to end users in the State (California Energy Commission, 2017a).

Aviation Fuel Commodity Assets

Similar to the vehicle fuel subsystem, the majority of jet fuel is transported by pipelines from the refinery to an intermediate terminal that stores said fuel before it is distributed to an airport by tanker truck or tanker barges. In the case of larger end users such as primary hub airports, jet fuel is directly distributed via pipelines. There are approximately 200 commercial airport facilities in the State that integrate the National Plan of Integrated Airport Systems that require fuel storage facilities within the airport's premises (California Department of Transportation, 2016a). In addition, 23 military airports represent other jet fuel end nodes in California (California Department of Transportation, 2012).

Tanker barges or vessels transport a smaller portion of aviation fuel. The smaller regional airports that are not connected to the pipeline transmission systems may receive their jet fuel by tanker truck. Some of the primary hub airports also have delivery of gasoline and other fuels that are exclusively used for their own ground fleet.

Marine Fuel Commodity Assets

The origin node for marine fuels is the refineries and the final destinations nodes are the ports. Intermediary terminals for marine fuel commodities are rare as most marine fuel producing refineries have pipeline systems that connect directly to docks where the fuel is pumped straight into the vessels.

According to the U.S. Department of Transportation (2016), there are 213 port facilities that handle all fuel products. It is not possible to determine from available information whether the ports are crude oil unloading terminals, intermediate fuel transloading facilities, or destination nodes for fuel products. In our analysis we therefore refer to them solely as "ports."

Gasoil Commodity Subsystem

This is a commodity subsystem as both its origin and destination nodes are refineries belonging to Phillips 66. The origin nodes are Santa Maria refinery and Carson, both refineries upgrade

crude oil to a semi-refined commodity (also known as gasoil) that is then transported via pipeline to the San Francisco and Wilmington refineries respectively.

2.3 Vital Inputs and Interconnected Infrastructures: The Case of Refineries

The intraconnections between and among various assets within the TFS as a whole is explored in section 2.1 and 2.2. However, a closer analysis of each asset within the TFS and its dependencies on vital inputs reveals a more complicated system in which the TFS is connected to many other critical infrastructure networks such as electricity, natural gas, and water to maintain normal operations. We define these critical infrastructures outside the TFS as the interconnected assets. In this section, we use the example of a refinery to illustrate the interconnections between critical assets within the TFS and other indispensable infrastructure networks (**Figure 4**).

An example of interconnected assets is: pipeline transmission of refined fuels (products) depends on electricity. If electricity fails, the pipeline pumping stations cease to operate, fuel is not transported, the intermediate transshipment nodes fail, and the associated section of the TFS is broken. Not knowing the real-time vulnerability of interconnected assets upon which pipeline managers depend increases uncertainty and is a very real threat to the resiliency of the TFS pipeline system. Other Fourth Assessment teams look at the impact of climate change on California's electricity, natural gas, and water infrastructures.

The refinery is itself a networked infrastructure that relies on a variety of unit operations for processing raw crude oil into usable end products. For our purposes here, these processes have four different phases: separation/distillation, conversion, enhancement, and blending. Each phase depends on vital inputs from other external networks to ensure the reliable and safe functionality of the refinery itself. In the conversion phase, for example, the refining process and utility heaters are in fact powered by large amount of natural gas fuels. Without stable connection to the natural gas pipeline network, a refinery cannot maintain its normal operations.

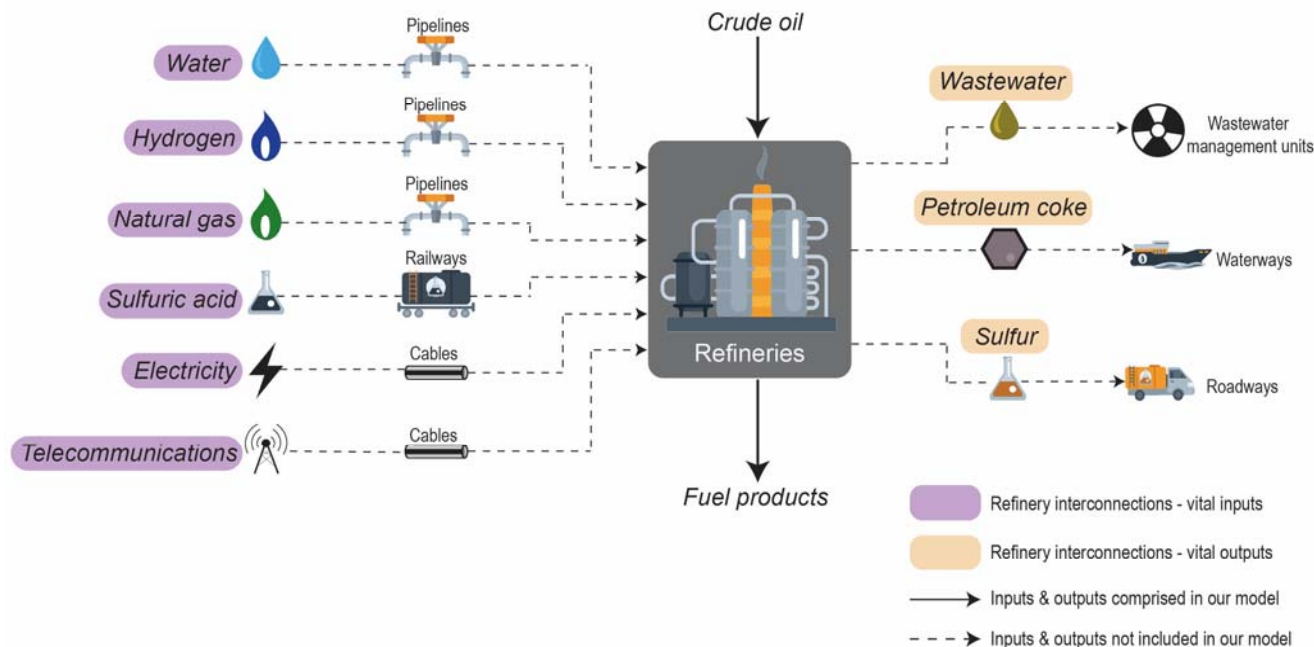

Figure 4. TFS refineries interconnections: vital inputs and outputs

Refineries also need hydrogen and sulfuric acid. The latter comes in by truck and is necessary for the alkylation process. On the other hand, there is considerable onsite generation of hydrogen, though this vital input is increasingly provided by industrial suppliers (U.S. Energy Information Administration, 2016). This substance comes in by pipeline and is important to lower the sulfur content of finished fuels. Natural gas is also essential for hydrogen production using steam methane reformers (U.S. Energy Information Administration, 2016). In the Los Angeles TFS hub, there is a hydrogen pipeline circuit shared by the different refinery organizations. Equally important, fresh water – and the infrastructure to provide it – is another vital interconnected input for refineries during the separation/distillation phase.

Not only do these facilities depend on a variety of vital inputs, their operational stability is linked to a reliable disposal of outputs such as waste water, sulfur, and petroleum coke. Refineries can generate large amounts of wastewater exposed to hydrocarbons. This wastewater is often produced in the separation/distillation phase (IPIECA, 2013) and is treated by refinery wastewater management units. Part of the used water is usually stored and temporarily disposed in open areas near the refineries and is particularly prone to environmental contamination, for example in the case of flooding. Since this wastewater contains dissolved salts and other corrosive chemicals, failure to effectively dispose of it can cause damage to a refinery's equipment, among other potential causes for disruptions.

Refineries also need to off-load sulfur, which is a residue that comes from hydro sulfurization, or the process of breaking down hydrocarbon molecules. Sulfur can be used by the agriculture industry as fertilizer, so it is reported not to present a major encumbrance for the output system and it is commonly off-loaded by trucks.

Petroleum coke is another major by-product of oil refining. It is a carbon-rich solid material that can accumulate in refinery barn units if not disposed of regularly. Petroleum coke needs to be disposed of approximately once every 15-20 days. It is considered by some stakeholders to be

an underestimated choke point of the output system, given that there are only a few alternatives for its disposal. Most of the petroleum coke is exported overseas and moves through the port and waterway transportation infrastructure.

A vital infrastructure in the real-time operations of refineries is electricity. In all four phases of the refining process, electricity is needed for equipment such as valves and pumps, as well as for telecommunications. An unscheduled and prolonged disruption in electricity negatively impacts the refineries and many other key TFS infrastructures.

Based on the electric supply requirements for the refining process example, it is clear that assets within the TFS network depend on not only other assets within the TFS schematic (intraconnections) but also external infrastructure networks for vital inputs and outputs, in real time and over time. Any usable model of the TFS cannot be portrayed in isolation of these interconnected vital infrastructures when it comes to TFS operations, let alone cycles for risk management and investment.

These inter-infrastructural connections fall beyond the scope of this research but are covered in varying extent by a few limited (geographical extent, scope) Fourth Assessment studies that assess potential impacts and adaptation options for infrastructure systems such as the electrical and natural gas systems. There is a need for future research on inter-infrastructural connections.

2.4 TFS Organizational and Institutional Frameworks

In the preceding sections, this chapter describes the TFS physical infrastructure dimensions by key assets and subsystems, simplified as nodes and links, their multimodal connections, their various products, and their multiple connectivities. Another necessary dimension to understand the fuel supply chain is the organizational network and its institutional framework.

The organizational network refers to inter- and intra-organizational relations for reliably operating and managing transportation fuel supply and distribution. Any such framework must represent the formal laws, regulations, procedures, and informal conventions, customs, and norms that shape the economic market and behavior of the TFS stakeholders. Just as no single schematic of the entire TFS as a sector is possible, so too would be any attempt to describe fully the organizational network and its various stakeholders, not least of which include the various regulators. Nevertheless, we present here an overview of the intricate organizational relations by explaining the different managerial systems related to ownership and operations of TFS assets as well as the market drivers of transportation fuel commodities with an emphasis on regulations. For the purposes of this report, and to make the following overview useful for our readers, we focus particularly on those relations already impacted by disruptions associated with flooding and wildfires and thus most likely to be disrupted in the future as well under model projections. An overview of the governance complexities of the TFS will be presented in the interest of uncovering TFS owner and operator responsibilities whilst facing current and projected wildfire and flooding exposure.

2.4.1 TFS Governance: Private and Public Spectrum Ownership and Operations

TFS governance involves both the public and private sectors in ownership and operations. The TFS key assets are mostly privately owned, while some *links*, such as roadways, waterways, and railways, present mixed governance models that balance private and public interests and influences. These governance models translate into specific responsibilities for the public and private sectors and to different characteristics of the ownership and operations of the assets.

Ownership TFS defines who owns the site, facility, and equipment, while operation refers to the management, maintenance, and other day-to-day activities (Jacoby, 2012). Owners generally partake in managing the portfolio of investments and implementing strategic changes such as selling and buying assets. Operators' decision making and costs usually involves responsibility and payment of: the workforce (salaries, wages, and benefits); the vital inputs (such as fuel, power, water, etc.); services such as inspection, maintenance and insurance; and all levels of governmental taxes and fees (Jacoby, 2012).

Ownership of TFS commodities adds another complexity to the management models of the TFS; in some cases, the same organization might own the upstream suppliers and its downstream buyers. Kinder Morgan, Inc. does not own the product flowing through its pipelines but is responsible for product delivery according to specifications only. This means an organization may own the commodity only and relies on other organizations for the storage and transportation of the feedstock or product. In other cases, it is possible that the same organization might own and operate the assets as well as own the commodity.

Furthermore, commodity trading can happen anywhere along the delivery chain and is conducted through supply contracts (Cragg et al., 2011). The contracts might change based on the oil delivery sequence; where ownership could be transferred at the wellhead point, the vessel, or barge delivery node. This contractual shift entails distinct pricing commonly referred to as wellhead prices, cargo prices, and barge prices. Product ownership also changes and follows similar price changing processes based on trade location in the distribution network.

When trade pertains to products leaving a refinery, the contracts refer to "refinery gate price;" and, when traded at some point in the pipeline network, the contract refers to "pipeline price." For trucking companies' contracts for example, the product trade will follow the "rack price" which is the price at the wholesale point. Before selling it to the end user, there might also be a "dealer-tank-wagon price" contract, when the commodity is delivered to gasoline stations and other retail outlets, where the consumer finally can access the product based on the "retail price" (Hilyard, 2012).

Public ownership is common for specific end and intermediate TFS nodes such as ports, airports, and terminals, and exists only for TFS links such as the roadways and waterways. Here, investment in infrastructure and planning strategies are carried out and funded by the public authority, who then offers leasing or carrier opportunities with the private market (Rodrigue et al., 2017). Private ownership may then come in forms of partnerships, corporations, or individuals. Individuals can own stocks, pension plans and mutual funds. Partnership and corporation ownership are more influential in most decision-making processes in private ownership (Miesner & Leffler, 2006).

For the majority of the TFS links such as pipeline and railways, private ownership and operation is the most common governance model. For these links, a variety of private organizations usually own the rights-of-way (ROW) and operate respective carrier infrastructures. Conversely, most roadways and waterways are provided and maintained as a public good by governments while the carriers (vessels and trucking company fleets) that move over them are privately owned and operated.

Private ownership and operation is also the dominant model for key TFS nodes. California is populated by privately-owned international oil companies, also referred as "super majors"

(Energy Intelligence Research, 2011; Herkenhoff, 2014), as well as privately-owned independent producers. Super majors are typically vertically integrated companies derived from a few decades of mergers and acquisitions, whereas independent oil companies are smaller and usually more recent players in the petroleum market. In most of the oil producing and refining countries, petroleum markets are controlled by state owned companies (Hilyard, 2012), while the U.S. and California oil markets are characterized by corporate governance models.

In summary, the TFS from a supply chain perspective relies on a complex mix of privately owned organizations that trade commodities through owned and/or operated infrastructures. This organizational network also includes several public entities that mostly own but sometimes also operate parts of these infrastructures. The public-private organizational spectrum is commonly described in transportation system planning and operation literature as the Public-Private Partnerships (PPP).

Ports and marine terminals provide examples of the complexity of management models within the TFS. Their PPP models fluctuate between public and private ownership and operation from an administrative, nautical management, infrastructure, and super structure perspective. Specific services for port operations and maintenance (such as pilotage, towage, mooring, and dredging) might also be shared through different sectors and organizations.

Addressing the implications of this organizational complexity, it is understandable why TFS governance in general is considered fragmented and inconsistent (Goldthau & Sovacool, 2012). Compared to other critical infrastructures (i.e. gas, electricity, water, etc.), TFS fragmentation is accentuated because it relies on a much higher number of organizations for the supply and distribution of fuel commodities. An approximation of the population of private owners and operators of the different TFS infrastructures portrayed in our model is presented in **Table 6** (for more details see Appendix A). Were we to add to this table those public owners and operators or organizations responsible for the reliability and safety of the different TFS infrastructures, the complexity would increase by greater magnitudes.

The petroleum market’s unpredictability based on global economic and political conditions (Hilyard, 2012) in conjunction with the complexity of actors involved results in high volatility ownership and operation of assets. Although the core structure of major organizations that own and operate key TFS infrastructures (such as refineries and pipelines) varies little, ownership of specific assets fluctuates continually through mergers and acquisitions. This fluctuation renders tracking of organizations even more difficult and increases uncertainties related to risk mitigation strategies that transgress the industry’s business model time frames.

Table 6. Estimated count of different TFS private owners and operators in California

Key TFS assets associated owners and operators		Approximate count of organizations that own and/or operate
Nodes	Refineries	10
	Terminals	30-35
	Ports	100-200
	Airports	150-200
	Gas stations	1000-2000
	Oil wells	750-800
	Pipelines	35-40

Links	Trucks	200-250
	Rail transportation	15-20
	Vessels and barges	No available data

2.4.2 Relationships Between Fuel Market Drivers, Emergency Management and Regulations

Market drivers of the TFS are embedded in the complexities of commodity trading. The oil industry is a commodity based business (Cragg et al., 2011) and the different stages of oil production and distribution determine important prices and basic economic competitive forces. However, relationships between supply dynamics and retail prices are more complicated than classic supply and demand markets because transportation energy is a vital commodity; thus, there is no substantial reduction of fuel consumption due to price increase. In emergency response situations, there might be those well-known spikes in fuel demand from the population due to “panic-buying and hoarding of fuels,” coinciding with first responder demand spikes (Schremp, 2016a). The demand spike coming from first responders in California is typically associated with firefighter fleet and equipment fuel needs. Trucking companies and other fuel distributing organizations have contracts with CalFire, for example, to ensure their fuel supply. The increases in wildfires we are projecting can only exacerbate these matters.

Fuel shortages in emergency situations are planned for and can be mitigated through Emergency-Fuels Set-Aside Programs coordinated by CalOES and other state agencies. These programs promote multi-agency and inter-agency coordination to facilitate incident prioritization and provide fuel for overall emergency response activities. However, emergency fuel actions also represent a disruption to the traditional fuel commodity market as they empower the Energy Commission and other government agencies to hold, control, and redirect petroleum stocks needed to ensure the health, safety and welfare of the public (Schremp, 2017b). Compared to other western states, California’s emergency fuel plans have a higher potential to interfere with the regional fuel market, as the state is the major fuel producer in the Petroleum Administration for Defense District 5 (PADD5). This region includes the western states of California, Arizona, Nevada, Oregon, Washington, Alaska and Hawaii (U.S. Energy Information Administration, 2015b). Another important factor influencing the western U.S. fuel market is California’s isolation from the rest of the Nation’s fuel supply. There are no substantial movements of product from the PADDs east of PADD5 or from the other states in PADD5 to California.

Finally, regulation is also a significant market driver. TFS associated regulations are intrinsically related to safety and environmental protection as well as to energy security and critical infrastructure protection. Recent inter-agency reports have described the federal regulatory framework for the TFS from a hazardous material safety perspective (National Academies of Sciences, Engineering, and Medicine, 2017; National Academies of Sciences, Engineering, and Medicine et al., 2017). These reports provide regulatory expertise that overlaps with transportation system analysis, energy market analysis, emergency management, transportation safety and operations oversight, and risk analysis at the federal level (National Academies of Sciences, Engineering, and Medicine, 2017; National Academies of Sciences, Engineering, and Medicine et al., 2017). These reports show that regulations concerning the TFS have been largely focused on safety of storage and transport of hazardous materials, and pollutant emission reduction, but less so on the reliability of transportation energy supply. The same tendency can

be observed throughout our stakeholder engagement process, where most TFS organizations refer to regulations that address wildfire and flooding exposure that are framed under hazardous material safety (cf. CH4.3.1. Marine Oil Terminal Engineering & Maintenance Standards and AB 864 on Oil Spill response).

Major actors for the TFS regulatory framework at the state level include: the California State Fire Marshal (equivalent of PHMSA), which focuses on hazardous material transportation and pipeline regulations in California, DOGGR (California Department of Conservation's Division of Oil, Gas and Geothermal Resources), and the State Lands Commission, which regulates oil exploration, production, and transportation of fuel commodities when these take place on sovereign land. Caltrans, the agency regulating transportation infrastructure safety and reliability for the movement of liquid fuels, California Office of Emergency Services (CalOES), which focuses both on emergency preparedness and critical infrastructure protection, and the Energy Commission, which is concerned with safeguarding the State's fuel supply, are also major actors.

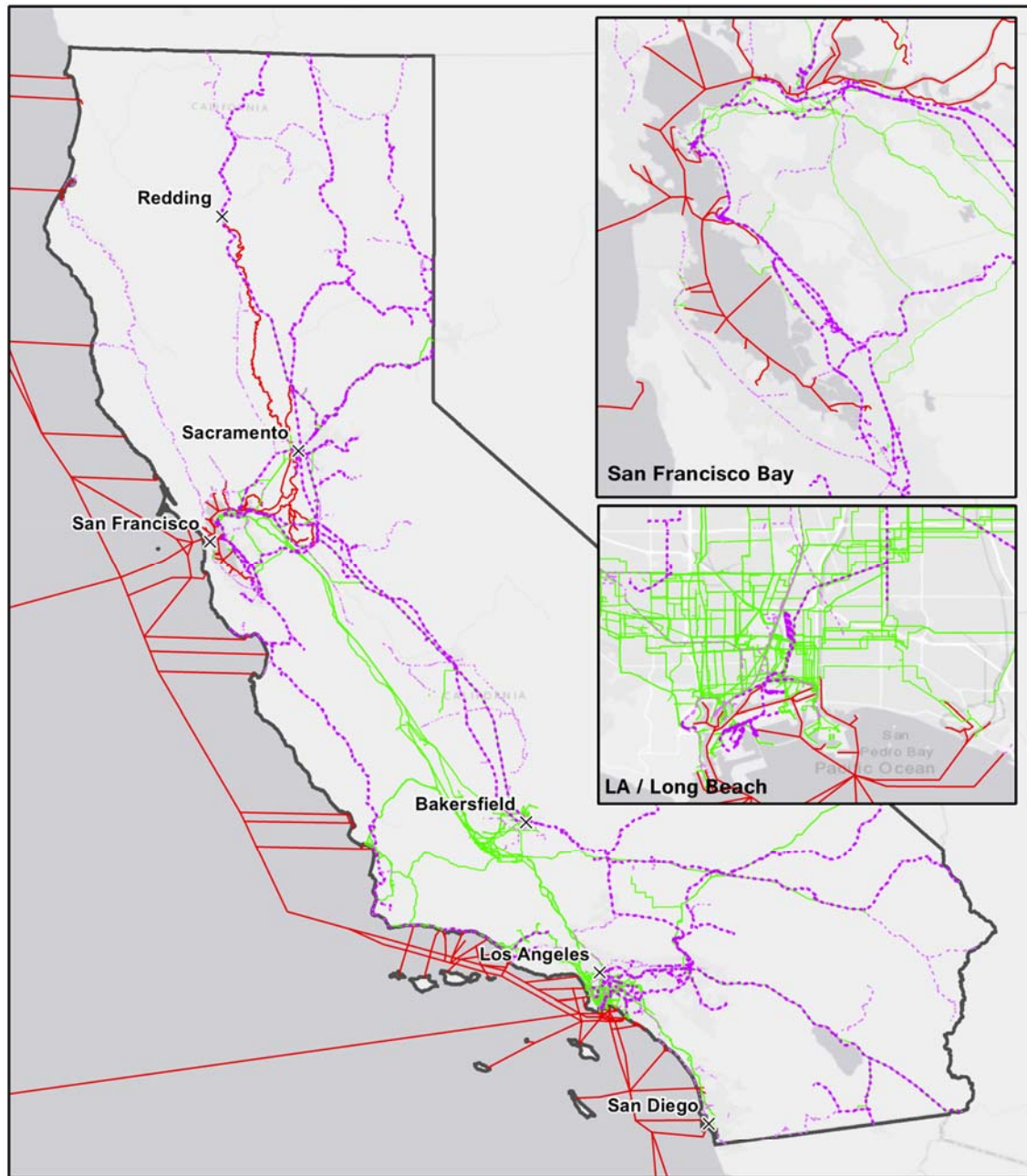

- Pipelines
- Navigable waterways
- ⋯ Railways (UP & BNSF)
- ⋯ Railways (final transects)

Figure 5. Long-haul TFS links in California: Pipelines, railways, and waterways



— Truck Routes for hazardous materials

Figure 6. Short distance TFS links in California: Roadways

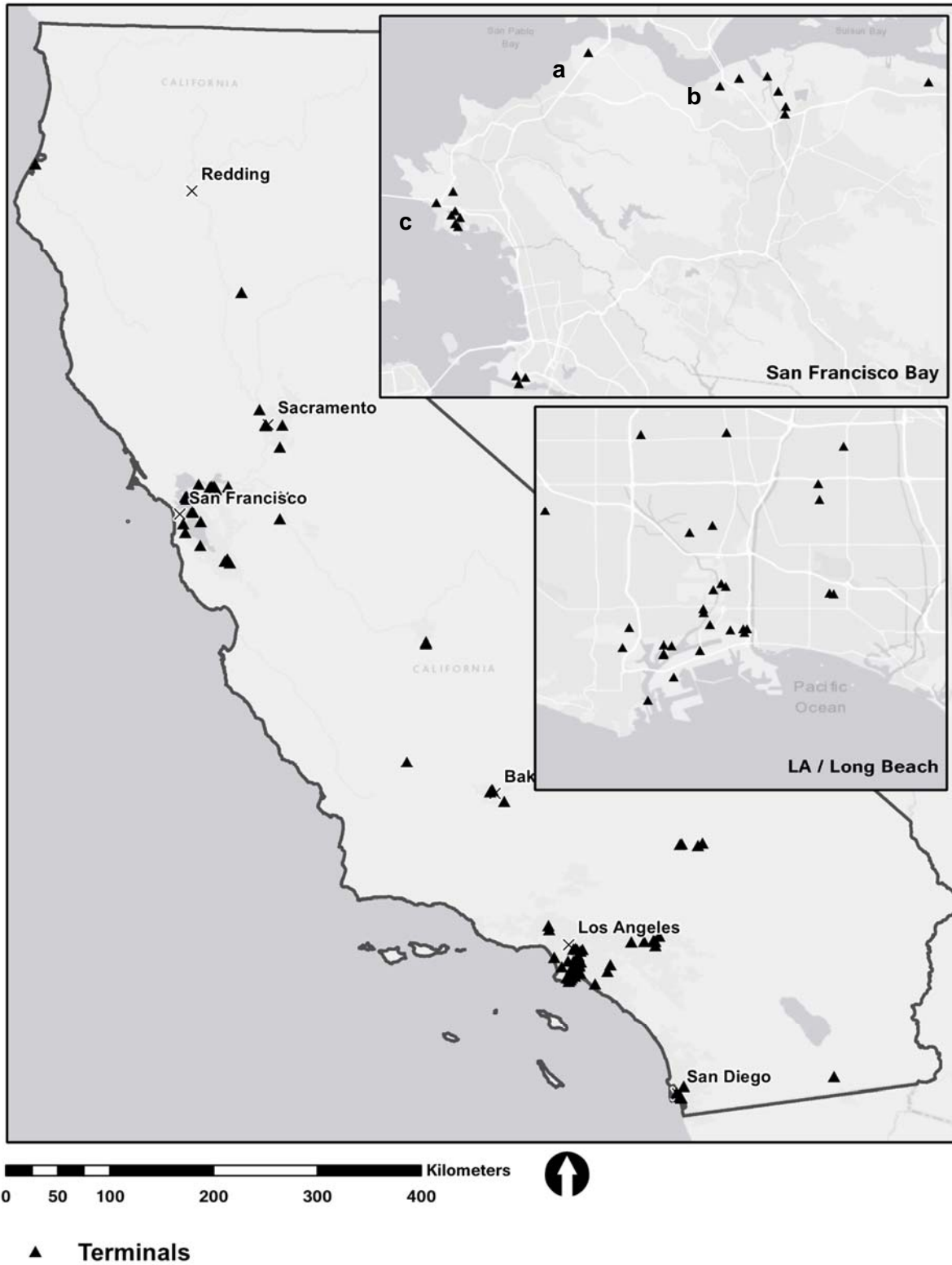

Figure 7. TFS terminals in California: Intermediate transshipment nodes. Example of multimodal terminals: a) Nustar. b) Shell. c) Chevron.



Figure 8. San Francisco Bay Area TFS hub terminal examples. a) Nustar rail/pipeline/marine terminal. b) Shell marine/pipeline terminal. c) Chevron marine/pipeline terminal.

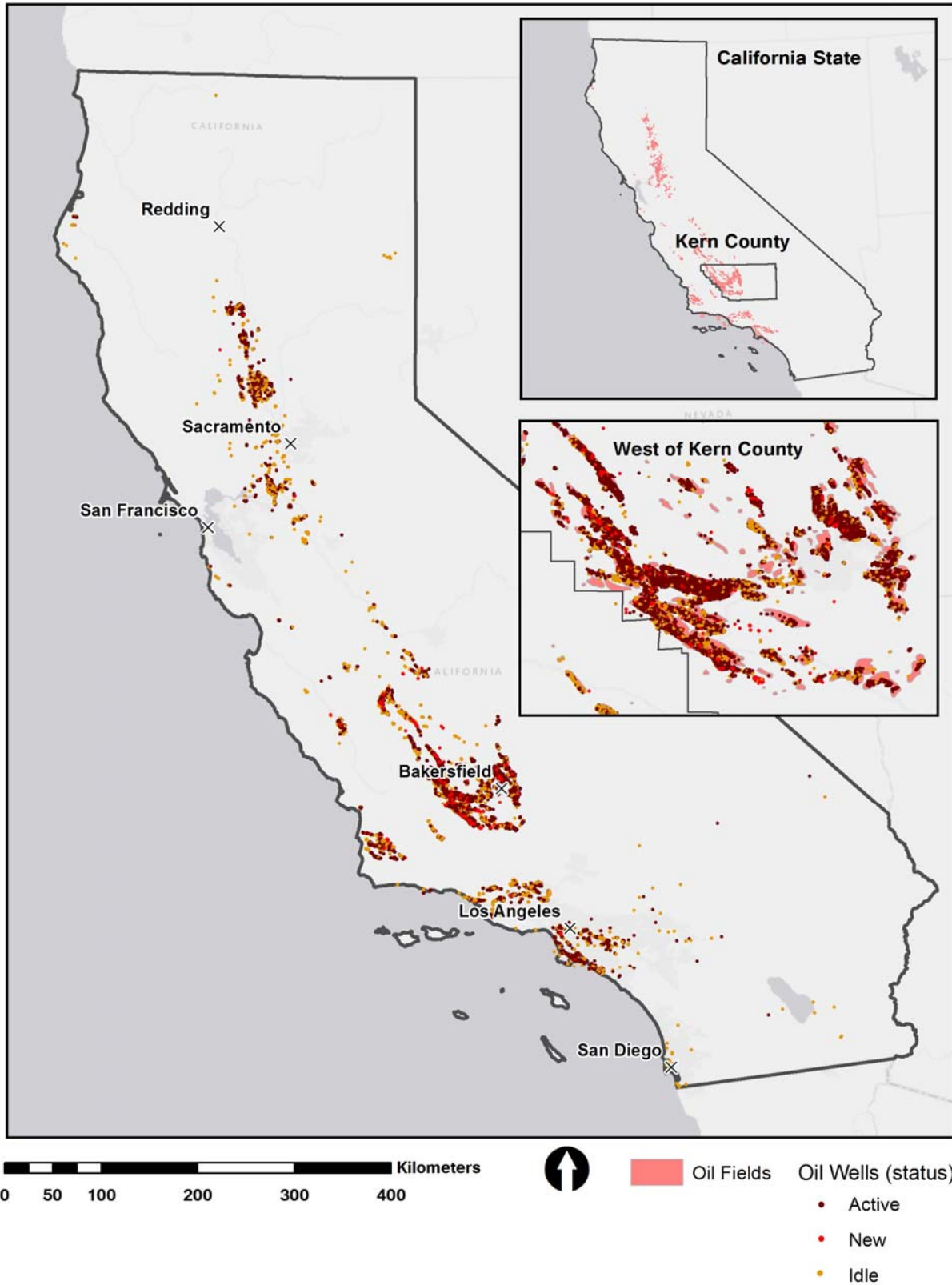

Figure 9. California's oil fields and active oil wells: Crude oil origin nodes. Digitized from (Division of Oil, Gas, and Geothermal Resources, 2017, 2018).

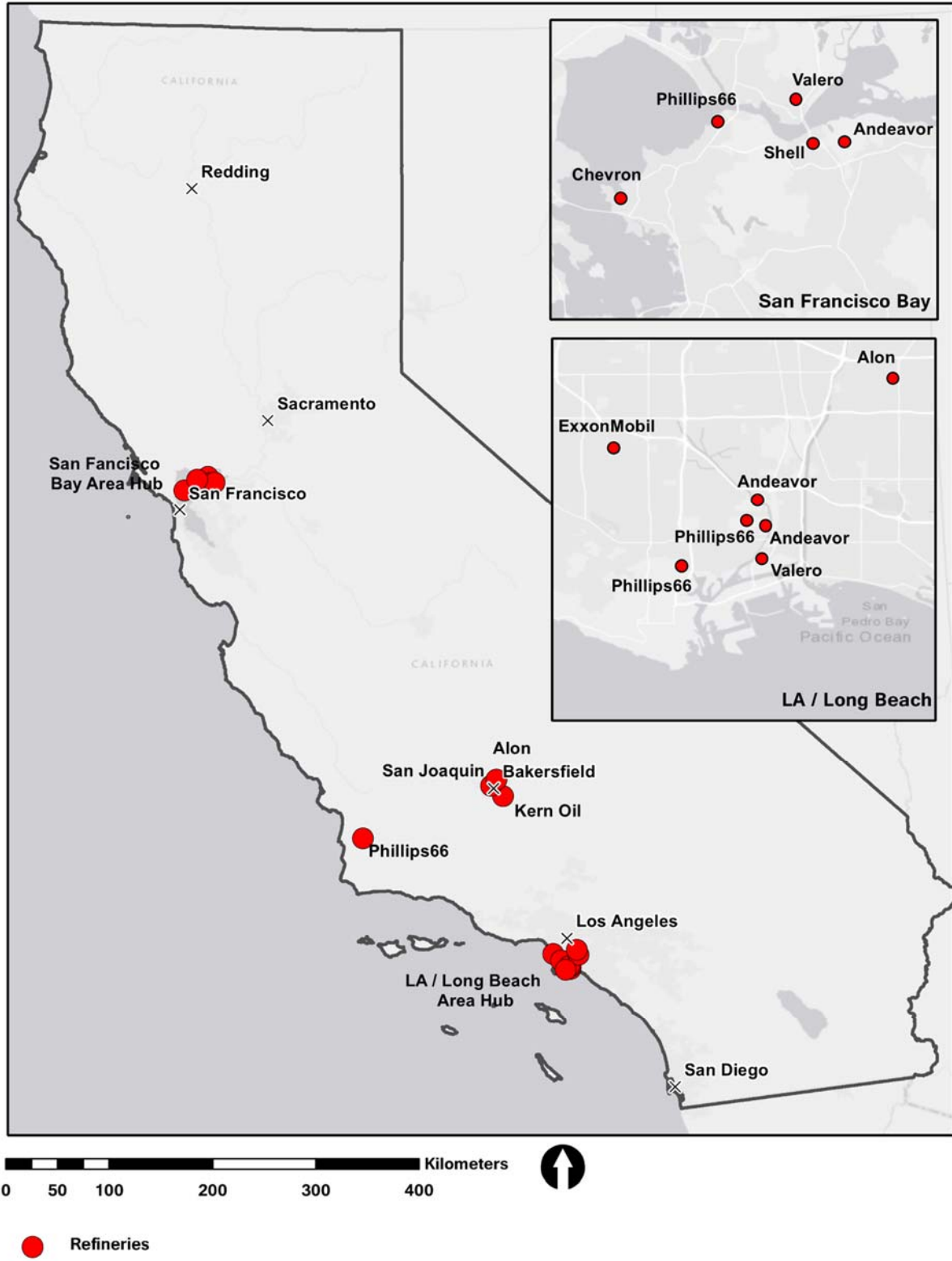
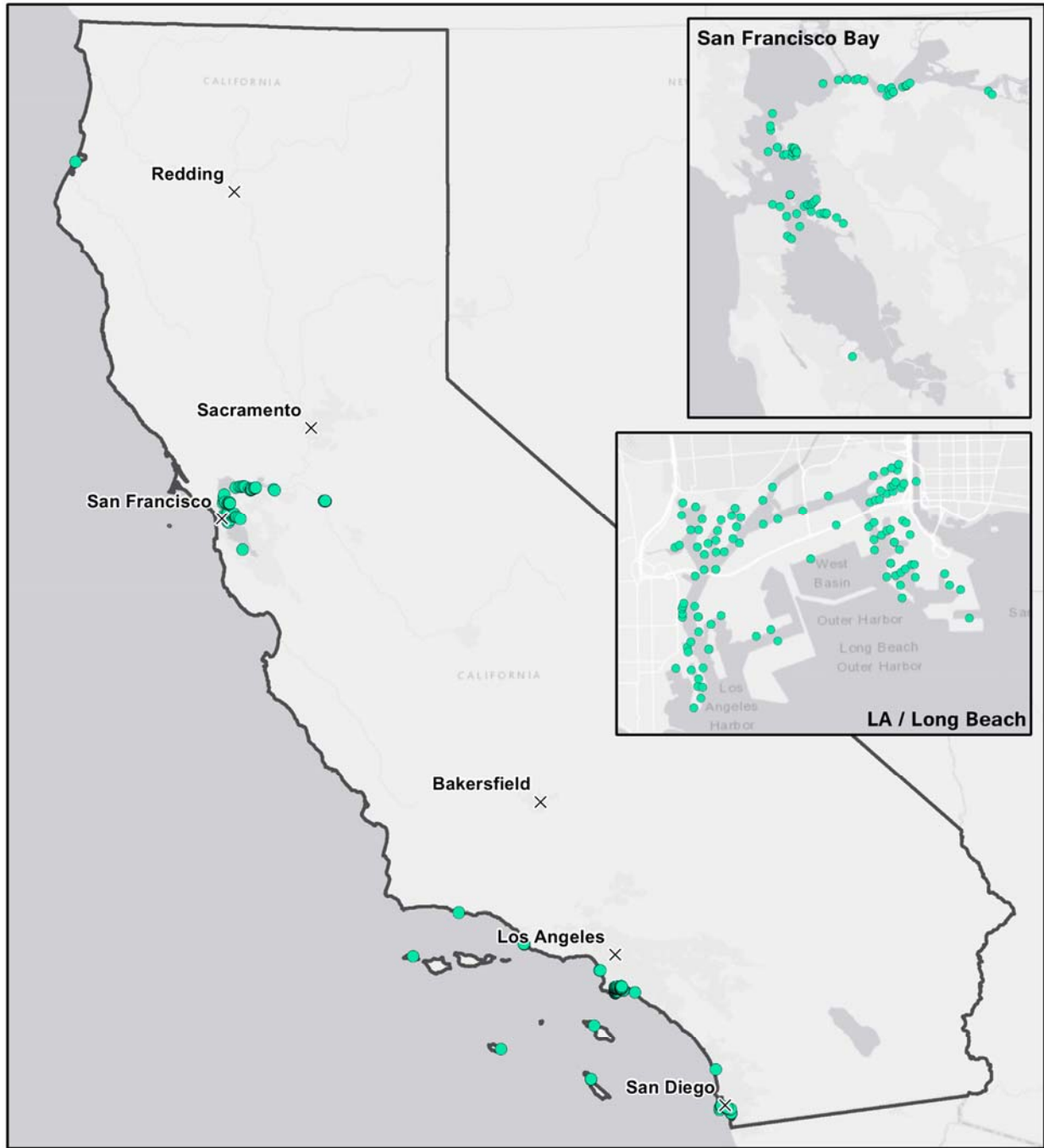

Figure 10. TFS refinery nodes in California



Figure 11. San Francisco Bay Area TFS Hub Refineries. a) Andeavor (ex-Tesoro) refinery. b) Valero refinery. c) Chevron refinery. d) Shell refinery. e) Phillips 66 refinery.



● Ports & Docks: handling fuel commodities

Figure 12. Port and dock nodes in California

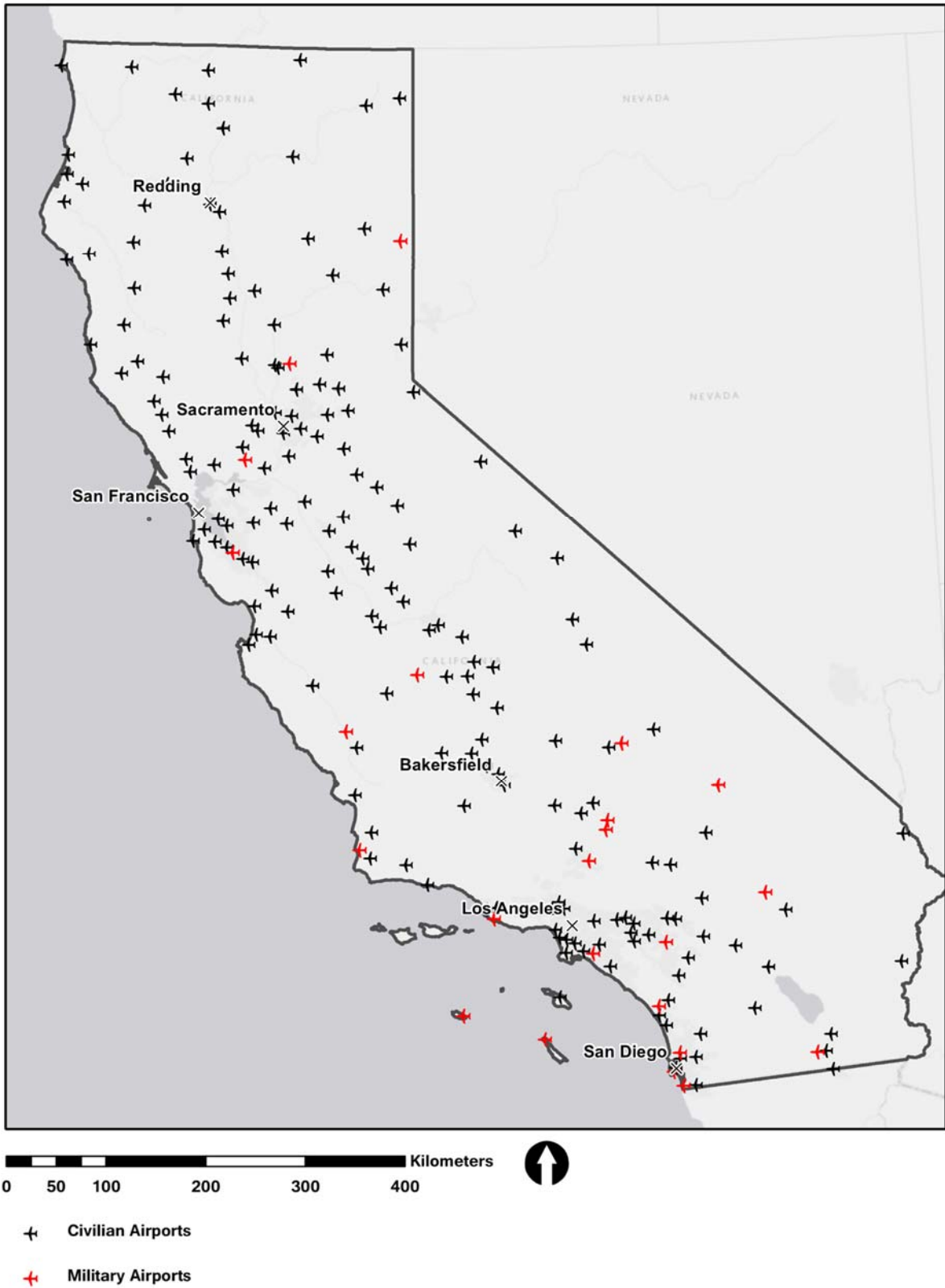

Figure 13. Airports in California: Jet fuel demand nodes



Figure 14. Gas stations in California: Motor vehicle demand nodes

3: Transportation Fuel Sector Exposure to Flooding and Wildfire Under Climate Change

Our evaluation of the potential exposure of California's TFS to extreme flooding and wildfire events under climate change combines two primary components: 1) a geospatial data model of TFS infrastructure assets (i.e. both nodes and links) across the State, and 2) spatial-temporal modeling of exposure to potential flood and wildfire events under climate change scenarios. This chapter describes the results of both our exposure analyses and of our spatial temporal modeling of coastal flooding, inland flooding, and wildfire through time and under numerous climate change scenarios. We start by describing how the climate change scenarios are selected.

Our exposure models contain both fine and coarse spatial resolutions. The models are initially run at coarse spatial resolution at the statewide scale. At the areas and assets of concern that indicated by our TFS stakeholders (see Chapter 4, for more details), we model the flooding and wildfire exposure of TFS assets at finer spatial resolution. Since computing time and resources increase exponentially as resolution moves from coarse to fine spatial resolution, our combination of coarse and fine resolution models allows us to feasibly study California, the third largest State in the US. Our geospatial data model of the State's TFS infrastructure is based on our conceptual model and the geospatial data we obtain to represent the TFS assets as a network of nodes and links (see Chapter 2 and Appendix A).

3.1 Future Scenarios

Our flood and wildfire simulations encompass a suite of scenarios regarding the climate and land use, so that the results can cover a range of different future possibilities. As described in section 1.4.1, we derive futures scenarios from combinations of two primary RCP scenarios of future GHG concentrations in the atmosphere along with four priority climate models and either three probabilistic SLR values (for coastal flooding), three LULC projections (for wildfire), or no additional component (for inland flooding).

The current set of RCP climate change scenarios adopted in the IPCC 5th Assessment (Moss et al., 2010) includes RCP 2.6, RCP 4.5, RCP 6.0, and RCP 8.5, each representing different levels of GHG concentration levels in the atmosphere (i.e. RCP 8.5 has the most concentration and suggests 2%/yr growth in carbon emissions through mid-century whereas RCP 4.5 has less concentration with a moderate policy that does not comply with what international powers agreed upon in Paris in 2015). There are no Fourth Assessment scenarios available for RCP6.5 or RCP2.6 and that RCP4.5 and 8.5 bracket what the State's research investigates, vis a vis resilience planning, our modeling is based on RCP 4.5 and RCP 8.5.

The RCP 8.5 scenario is a high GHG concentration scenario with high population, modest improvements in technology and energy use, high-energy demand, and no climate change policies. RCP 4.5 is a scenario that includes climate change mitigation, such as a widespread shift to electric energy, lower emission technologies, and implementation of carbon capture and storage.

Global climate models are used in conjunction with RCPs to project specific climate variables in future climate. For the same geography and input conditions, different climate models may produce different climate projections due to the internal differences between the models. We

utilize the four GCMs selected by the Fourth Assessment - namely HadGEM2-ES (warm/dry), CNRM-CM5 (cool/wet), CanESM2 (average), and MIROC5 (complementary) - as they together cover a broad range of climate model projections in California. For a detailed description about the model characteristics (i.e. warm/dry, cool/wet, average, and complementary), please refer to **Table 1** in section 1.5.1 and Appendix B.

Finally, as described further in sections 3.2.1 and 3.2.2 below, our scenarios include a component of either probabilistic SLR or LULC projections (or no additional component for inland flooding). Combining these components (RCP + GCM + SLR or LULC or no component) results in 24 coastal flooding scenarios, 8 inland flooding scenarios, and 240 wildfire scenarios (**Table 1** in section 1.5.1). For more detailed information regarding the scenarios, please refer to section B.1 in Appendix B.

3.2 Exposure of Transportation Fuel Sector Assets

Our results show that California's TFS assets are differentially exposed to flooding and wildfires, which may disrupt fuel distribution or cause significant infrastructure damage. Our coarse resolution, statewide models show that small proportions, such as 1% of gas stations and 12% of docks (average percentages over five 20-year periods between 2000 and 2100, similar below), of the statewide assets are exposed to coastal flooding (see section 3.2.1) and higher proportions, such as 48% of pipelines and 70% of roadways, are exposed to wildfire (see section 3.2.2.2 and Supplementary Table 2 in Appendix C). The exposure, both in terms of spatial extent and severity, is likely to increase with time, particularly for coastal flooding driven by continuously rising sea levels.

In addition to the statewide models, we produce fine spatial resolution (i.e. 5 m or 16.4 ft) models in selected areas so that the flooding (see section 3.2.1) and wildfire exposure (see section 3.2.2.3) results can better inform the TFS stakeholders about the potential vulnerability of their assets at local scales in the face of climate change.

3.2.1 TFS Assets Exposed to Flooding

TFS assets in low-lying, flat, and coastal areas such as the San Francisco Bay Area and Sacramento-San Joaquin Delta in Northern California, and Long Beach – Huntington Beach region in Southern California, are exposed to coastal flooding according to our results.

Our 50 m (164 ft) spatial resolution coastal model finds that a small proportion of each TFS asset examined is exposed to any depth of coastal flooding in the State. Docks and terminals are the most exposed assets with on average 12.21% and 11.85% of them flooded between 2000 and 2100, whereas only 0.92% of the State's gas stations are exposed.

From the 2000-2020 period to the 2080-2100 period, the exposed proportions of the assets increase from a narrower range between 0.5% (gas stations) and 9% (terminals) to a broader range between 2% (gas stations) and 22% (docks). In addition, increased proportions of the assets are exposed to more severe levels of flooding overtime. During the 2000-2020 period, a range between 0% (gas stations) and 5% (docks) of the assets are exposed to extreme flooding with depth greater than 2.0 m, and this range increases to between 0.2% (gas stations) and 6% (docks) during the 2080-2100 period.

In addition to the statewide 50 m (164 ft) resolution model, we also conduct 5 m (16.4 ft) simulations for coastal and inland flooding in specific areas during specific time horizons, so

that these customized results can better inform the stakeholders. These specific areas include Richmond, Concord, Martinez, Stockton, Brisbane, and San Francisco International Airport in the north and Los Angeles/Long Beach Port and San Diego in the south. We simulate these areas at high-resolution during the 2020-2040 period that stakeholders are more interested in because it fits with their near-term investment and planning timeframes.

We simulate statewide-coastal flooding caused by projected SLR and storm surge at 50 m (164 ft) spatial resolution using a 3Di hydrodynamic model (Stelling, 2012b). The 3Di model takes time-series water levels as its input to produce flooding extent and depth by user-defined time steps. To obtain the time-series water levels, we extract high sea level events from the hourly sea level projections by Cayan, Kalansky, Iacobellis, & Pierce (2016). This sea level projection includes contributions from SLR, storm surge, and tides. Cayan et al. (2016) project SLR probabilistically by sampling from a distribution of five primary global SLR components respectively under RCP 4.5 and 8.5. The Fourth Assessment recommends research teams to consider three SLR value percentiles under each RCP: the 50th, 95th, and 99.9th percentiles. Cayan et al. (2016) project storms for the four priority GCMs in the Fourth Assessment. Combining the two RCPs, three percentiles of SLR values, and four GCMs results in 24 scenarios of hourly sea levels between 2000 and 2100.

For every 20 years and each of the 24 scenarios, we identify a high sea level event - the 72-hour period with the highest sea level in the 20-year interval - and use hourly water levels during the event as input to the 3Di model. We thus identify a total of 120 events for the five 20-year intervals between 2000 and 2100 under the 24 scenarios. For each event, we use an hourly time step and combine the hourly results to produce a single map of the largest flooding extent and the highest depth during the event. In addition, we rank the 24 events (representing different RCP, SLR percentile, and GCM combinations) in a 20-year interval by their peak sea level to identify the maximum, median (i.e. the middlemost event with higher peak sea level), and minimum events to quantify the range of flooding scenarios. A detailed description of this coastal flooding model can be found in Appendix C. The remainder of this section documents TFS exposure to flooding using the results from *the median event among the combined RCP 4.5 and 8.5 scenarios* (i.e. one middlemost event from the 24 scenarios per 20-year interval). We include exposure under other events (e.g. the maximum and minimum across the 24 scenarios in each 20-year period) in Appendix C to indicate the range in TFS assets' exposure to future coastal flooding.

Our median scenario event simulation over the five 20-year intervals indicates that flooding extent and severity are likely to increase with rising sea level and intensified storms in the future. In the 2000-2020 period, 1943 km² (750 square miles) of California's coastal area is exposed to flooding. This number increases slightly to 2042 km² (789 square miles) during the 2020-2040 period, and eventually to 2924 km² (1129 square miles) during the 2080-2100 period (**Figure 15 (a)**). We further analyze the median scenario under RCP 4.5 and 8.5 respectively to highlight the differences in coastal flooding under the two. In general, RCP 8.5's median scenario results in more areas flooded than RCP 4.5's, as RCP 8.5 assumes a higher GHG concentration and presumably greater SLR. However, we find that this expected pattern reverses for the two time periods between 2000 and 2040 (**Figure 15 (a)**), because in some regions the hourly sea level projections by Cayan et al. (2016) include higher peak sea levels for RCP 4.5 than for RCP 8.5. While the projections constantly have higher SLR for RCP 8.5 than for RCP 4.5, they sometimes project weaker storm surges for RCP 8.5, particularly when the

projections are before 2040. Please refer to Supplementary Table 1 in Appendix C for a list of the median scenarios' peak sea levels by geographic region under RCP 4.5 and 8.5, respectively.

The distribution of maximum flooding depths during the median scenario events becomes more severe as the analysis moves towards 2100. We classify maximum flooding depth during the events into six classes:

- no flooding (0 m) (0 ft.)
- low (0 m - 0.5 m) (0 - 1.64 ft.)
- moderate (0.5 m - 1.0 m) (1.64 - 3.28 ft.)
- high (1.0 m - 1.5 m) (3.28 - 4.92 ft.)
- very high (1.5 m - 2.0 m) (4.92 - 6.56 ft.)
- extreme (more than 2.0 m) (more than 6.56 ft.)

As shown in **Figure 15** (b), during the 2000-2020 period, approximately 16% of the flooded area experiences low level flooding. The areas experiencing low level flooding decrease to 14 % during the 2020-2040 period, and to 9% during the 2080-2100 period. Meanwhile, areas under extreme flooding increase from 42 % during the 2000-2020 period, to 45% during the 2020-2040 period, and dramatically to 62% during the 2080-2100 period. The increased portion of areas under deeper flooding is a result from California's steep coastal topography, where the flooding has limited areas to expand horizontally but more spaces to accumulate vertically.

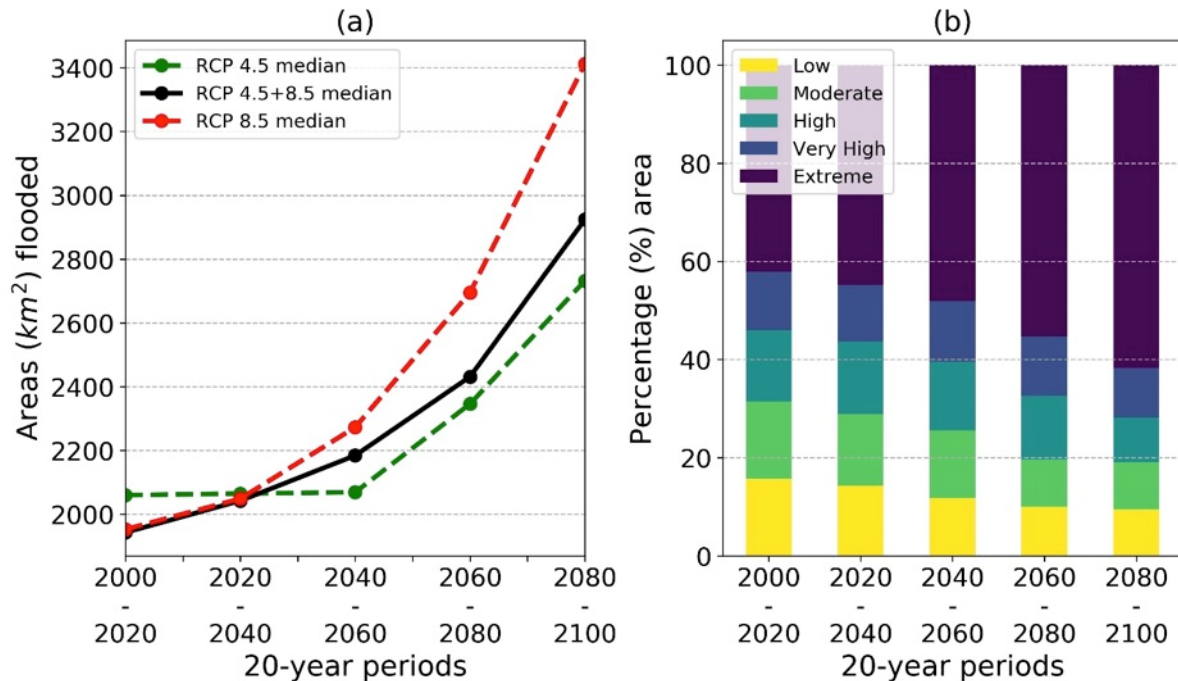

Figure 15. Statewide coastal flooding exposure during the high sea level events between 2000 and 2100. (a) flooding exposure during the median scenario event under RCP 4.5 and RCP 8.5 respectively, and combined RCP 4.5 and 8.5. (b) Percentage area in the five flooding exposure classes during the median scenario event under combined RCP 4.5 and 8.5.

Figure 16 highlights two areas with established concentrations of TFS infrastructure and illustrates their flooding exposure: the San Francisco Bay Area (Bay Area) and Sacramento-San Joaquin Delta (Delta) in Northern California, and Long Beach-Huntington Beach area in Southern California.

The Delta in particular is likely to be extensively flooded as sea levels increase, and it currently accounts for most flooding statewide as many Delta islands are 3-8 m (9.84-26.25 ft.) below sea level (Ingebritsen, Ikehara, Galloway, & Jones, 2000). While Delta islands are reported to be protected by more than 1700 km (1056 miles) of levees (Mount & Twiss, 2005), these levee structures are too granular to be detected in our statewide modeling at 50 m (164 ft) spatial resolution (see Appendix C for details). This results in additional waterflow pathways and overestimation of flooding in our coarse model results, particularly in low-lying areas protected by levees. While these waterflow pathways and the resulting flooding are artifacts due to the coarse modeling resolution, considerable contemporary concern remains over the robustness of existing levees to withstand failure and overtopping events, which have occurred in the past and are predicted for the future. For example, a levee failure in 1969 at Sherman Island in the Delta cost the US Army Corp of Engineers on the order of \$600,000 to repair, re-slope, and re-grade the levee break (Hanson, 2009). Moreover, most of these levees were constructed with standard cross sections of 0.3 m (0.98 ft.) above the estimated 100-year flood elevation

(Ingebritsen et al., 2000); therefore, they are susceptible to overtopping under future SLR and intensified storms.

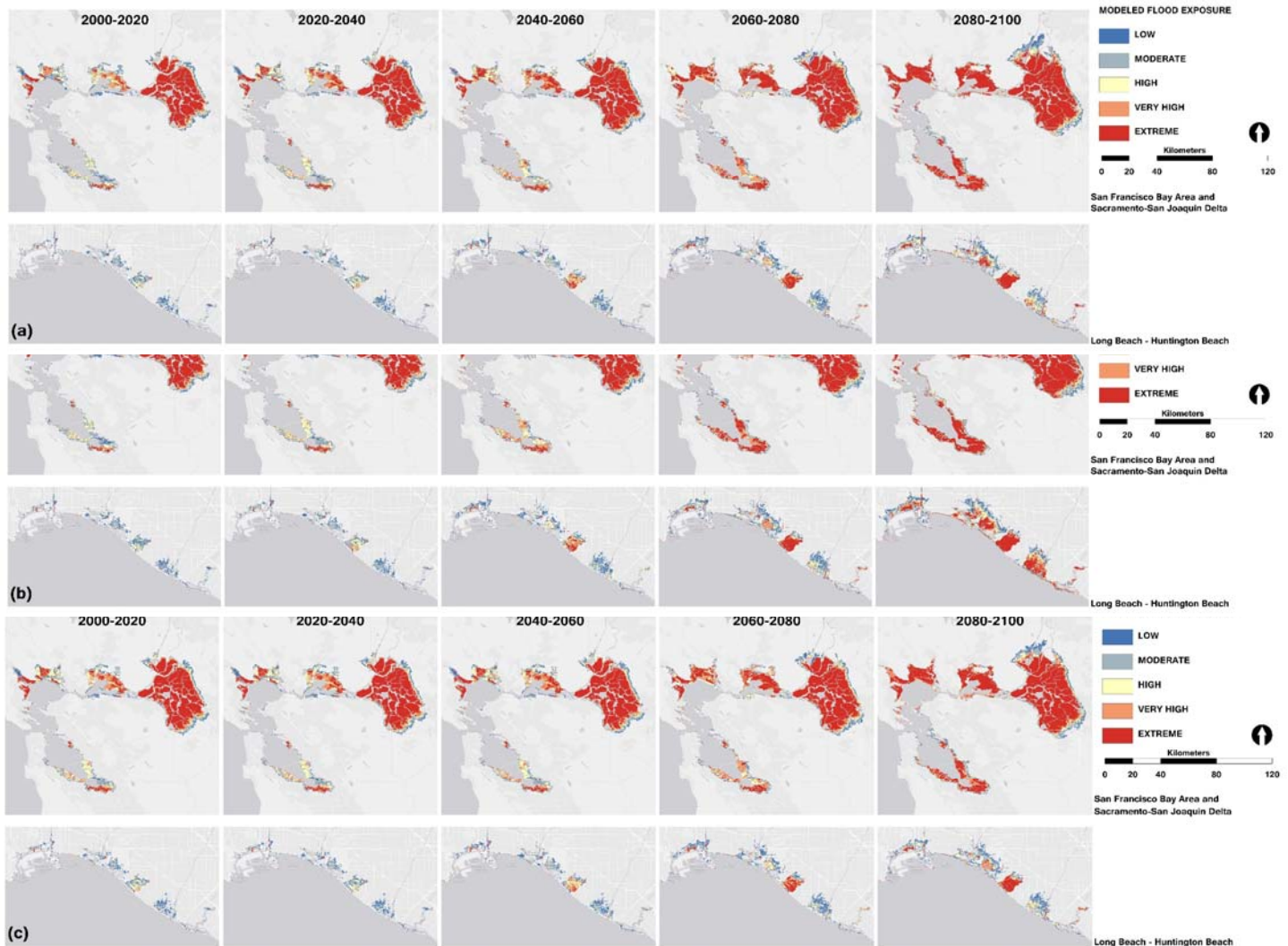

Figure 16 Modeled flooding exposure classes for twenty-year periods between 2000 and 2100, zoomed to San Francisco Bay Area and Sacramento-San Joaquin Delta in Northern California, and Long Beach – Huntington Beach in Southern California. (a): the median scenario event in the 24 high sea level events combining the two RCPs (8.5 and 4.5), four GCMs, and three percentiles of SLR values (50th, 90th, and 99.9th). (b) the median scenario event in the 12 high sea level events combining RCP 8.5, the four GCMs, and three percentiles of SLR values (50th, 90th, and 99.9th). (c) the median scenario event in the 12 high sea level events combining RCP 4.5, the four GCMs, and three percentiles of SLR values (50th, 90th, and 99.9th). As there were two middlemost events in even number of events (i.e. 12 or 24), we used the middlemost one with higher peak sea level as the median.

To measure the potential exposure of TFS assets statewide to inundation under future climate scenarios, we intersect the geospatial model of statewide TFS asset – nodes and links – locations (see Chapter 2) with the median scenario high sea level events. We calculate the exposure of the TFS links, including pipelines, roadways, and railways, as the length of the asset within each

flood depth class. For the TFS nodes that have footprints in our geospatial model, including refineries, terminals, and oil fields, we calculate the exposure as the area of their footprints in each flood depth class. For the TFS nodes that we do not have footprints in the model, including docks, airports, and gas stations, we measure their exposure as the number of assets in each flood depth class. In this way, we quantify exposure as the amount of an asset directly exposed to the flooding of the median scenarios high sea level events. We summarize flooding exposure by TFS asset category in absolute amount (Supplementary Table 2, Appendix C), and in percentage values (Supplementary Table 3, Appendix C). This exposure analysis is a first step to understand how the TFS is impacted under the projected flooding. The analysis does not reflect the ripple effect of exposure, where when one segment of the TFS assets is flooded and operations disrupted, the assets connecting to this segment can also be affected. Such analysis would also need to be combined with additional information about whether an asset's operation is disrupted due to exposure to flooding.

The exposure of TFS assets to the simulated flooding increases over the total period of analysis, and critical nodes including terminals, docks, and refineries have higher proportions exposed compared with the other assets (**Figure 17**). Our simulated flooding occurs mainly in flat, coastal, and low elevation regions, resulting in different exposure patterns of the assets. Assets that are distributed throughout the State (e.g. gas stations, pipelines, and roadways) tend to have lower exposure (i.e. the proportion of the statewide asset being exposed) when compared to the ones that are concentrated in coastal zones (e.g. refineries, terminals, and docks). Gas stations are the least exposed asset with an average of 1% of them statewide exposed to the simulated flooding in the five periods. This low amount of exposure is due to the wide distribution of gas stations throughout the State. Docks and terminals are among the most exposed assets with 12% of each exposed respectively on average in the five 20-year planning periods. The concentration of docks and terminals along the coast results in their high flooding exposure. Flooding exposure could disrupt the operations in docks and terminals and affect the State's fuel supply and distribution.

TFS assets become more exposed to flooding, particularly greater depths of flooding, when our analysis moves into the future with rising sea levels. In the 2000-2020 period, a range between 0.4% (gas stations) and 9% (terminals) of the assets are exposed to any flooding, and this range slightly increases to between 0.5% (gas stations) and 10% (terminals) in the 2020-2040 period and finally to a broader range of 2% (gas stations) and 22% (docks) in the 2080-2100 period (**Figure 17(a)**). Assets are also likely to experience deeper levels of flooding. During the 2000-2020 period, a range between 0% (gas stations) and 5% (docks) of the assets are exposed to extreme flooding with depth greater than 2.0 m, and the range increase to between 0.2% (gas stations) and 6% (docks) during the 2080-2100 period (**Figure 17(b-j)**).

Importantly, we find that exposure characteristics vary by geography (northern versus southern California), asset type, and ownership (large versus small operator). Most product pipelines in Northern California that are exposed to the simulated coastal flooding in our analysis are operated by a single, large operator (Kinder Morgan, Inc.) with a small fraction of its pipelines exposed. The limited exposure should not be treated as grounds for complacency, since the projected flooding could impact a key interconnected infrastructure (e.g., electricity), which would have direct effect on real-time pipeline operations. Conversely, in southern California, flooding exposure is distributed among several operators with some small operators highly exposed, indicating that these operators could be severely disrupted individually due to the

limited redundancy for rerouting within their own pipeline systems. A more detailed coastal flooding exposure analysis is included in Appendix C.

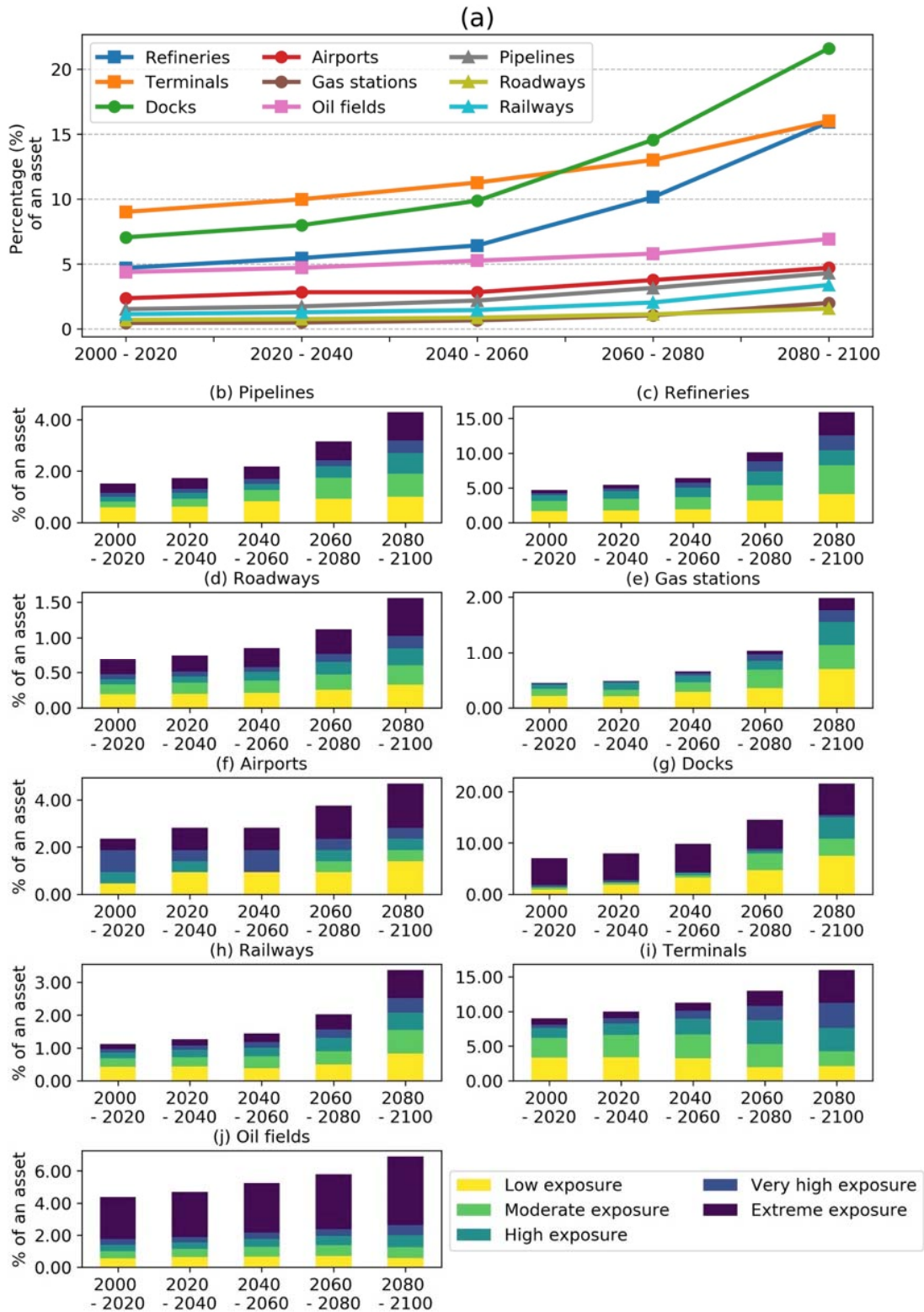

Figure 17 TFS assets' exposure to flooding. (a) The percentages of each of the nine TFS asset exposed to any depth of flooding during each 20-year period. (b) – (j) the percentages of a TFS asset exposed to the different classes of flooding depth during each 20-year period.

We model selected time periods and areas at a fine 5 m (16.4 ft) spatial resolution to more rigorously measure flooding exposure at a level that stakeholders find more useful for their near-term planning. Stakeholders express interests especially in the 2020-2040 period, whereas we also model the 2080-2100 period to show the potential for exposure far in the future.

The simulated areas are chosen based on flooding exposure in the statewide model, the concentration of TFS assets, and the inputs from TFS stakeholders. The areas include Concord, Martinez, Richmond, Stockton, Brisbane, and San Francisco International Airport in Northern California, and Los Angeles/Long Beach Port and San Diego in Southern California. We model the maximum, minimum, and median scenario high sea level events (from the 24 total events), for the 2020-2040 period and 2080-2100 periods respectively. The differences between the three scenarios (i.e. max., median, and min.) increases over time. For example, in Richmond, where a Chevron refinery is located, there is a -1.5% to 1% difference (i.e. min. and max. scenario compared to the median) in flooded areas in 2020-2040 and a -14% to 17% difference in 2080-2100. A detailed description of local scale coastal flood modeling can be found in Appendix C.

Due to the differences in spatial resolution and level of detail between our 50 m (164 ft) resolution statewide model and 5 m (16.4 ft) resolution local model, the simulated exposures from the two models differ somewhat. These differences indicate the importance, if not the necessity, of conducting fine spatial resolution modeling with more precise topographic data at areas of interest. **Figure 18** illustrates such differences using the median scenario high sea level event simulated in Richmond, Northern California, during the 2020-2040 period. While the statewide model and the local model show similar flooding extent and depth distribution (**Figure 18**), the actual exposure values differ in degree (**Table 7**).

Not incidentally, this study and previous studies (Haile & Rientjes, 2005; Ju et al., 2017) have found that flood modeling is sensitive to resolution and the accuracy of input topographic data. Such sensitivity is due to the fact that flooding models need precise topographic information to correctly identify waterflow pathways. Low-quality topographic data with large errors or coarse resolution tend to inaccurately represent the actual waterflow pathways and therefore result in over- and under-estimation of flooding. This sensitivity is more salient in flat and low-lying regions where the low-quality topographic data could miss fine changes in the topography (e.g. levees and channels) and estimate flooding differently from the high-quality data (i.e. fine resolution and more accurate).

Table 7. Contrasting between the two modeling resolutions in terms of total exposed area and percent area by different depth levels, illustrated by the median scenario high sea level event simulated in Richmond, Northern California, during the 2020-2040 period.

Exposure level	Local model (5 m)		Statewide model (50 m)	
	Area (km ²)	% in total exposed area	Area (km ²)	% in total exposed area
Low	0.53	13.90%	0.88	20.46%
Moderate	1.51	39.65%	1.77	41.38%
High	1.18	30.83%	1.04	24.37%
Very High	0.21	5.43%	0.17	4.03%
Extreme	0.39	10.19%	0.42	9.76%
Total exposed	3.81	100.00%	4.28	100.00%

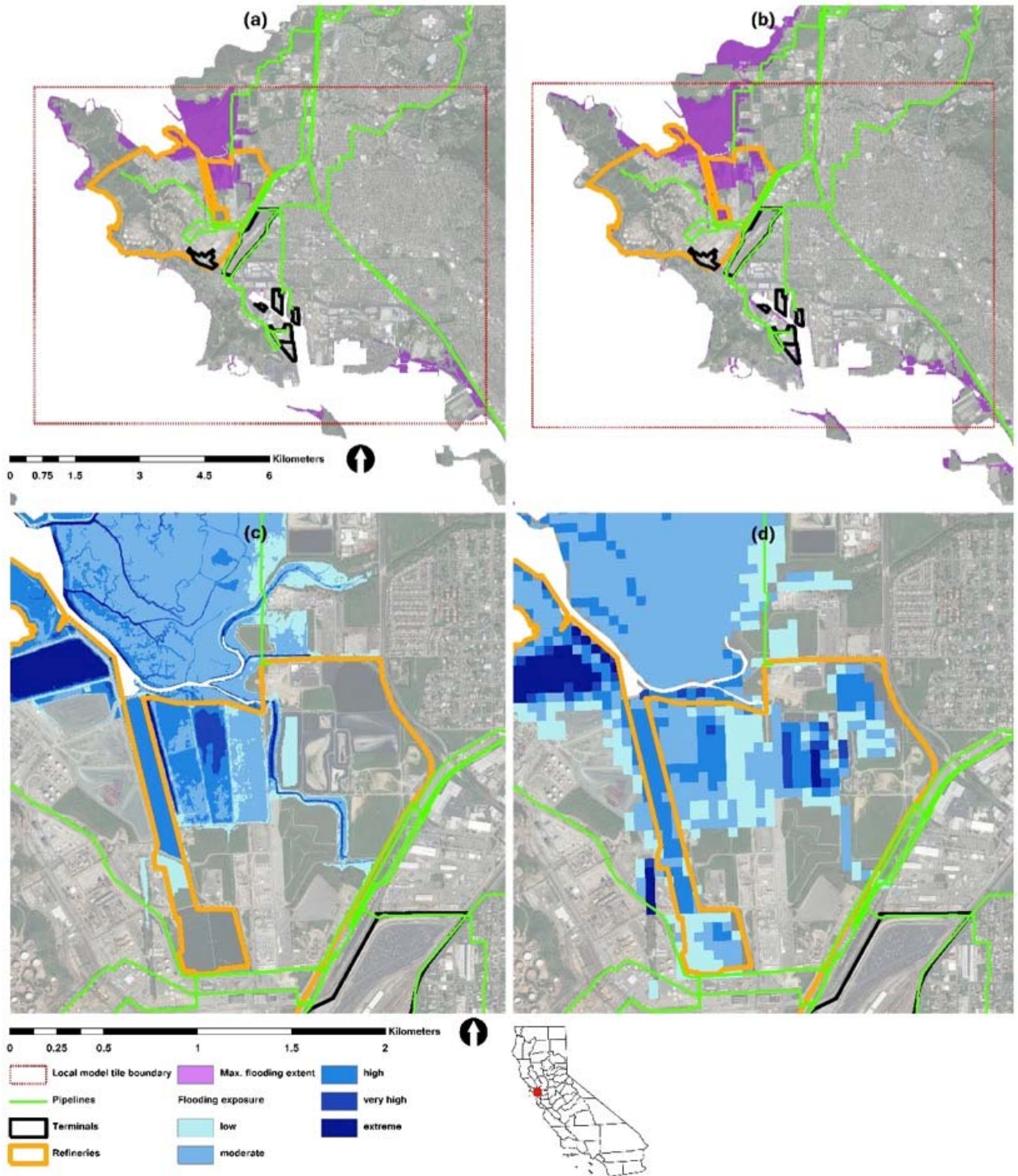

Figure 18. Contrasting the two modeling resolutions, illustrated by the median scenario high sea level event simulated in Richmond, Northern California, during the 2020-2040 period. (a) and (c) show results from the statewide coastal flooding model at 50 m (164 ft.) spatial resolution. (b) and (d) show results from the local flooding model at 5 m (16.4 ft.) spatial resolution. (a) and (b) highlight the differences in flooding extent, whereas (c) and (d) highlight the differences in flooding depth values classified into the five exposure classes.

We also model inland flooding using projected rainfall events in the selected areas (see Appendix C for details). **Figure 19** shows an example of projected inundation at San Francisco International Airport under the median scenario high sea level event and median scenario rainfall event. This highlights the differences between inland flooding and coastal flooding. While coastal flooding is more spatially concentrated in low-lying coastal areas, inland flooding is more widely distributed over the modeled area (**Figure 19** (a) and (b)). Although diffuse, inland flooding tends to produce shallower inundation depths compared with coastal flooding (**Figure 19** (c) and (d)).

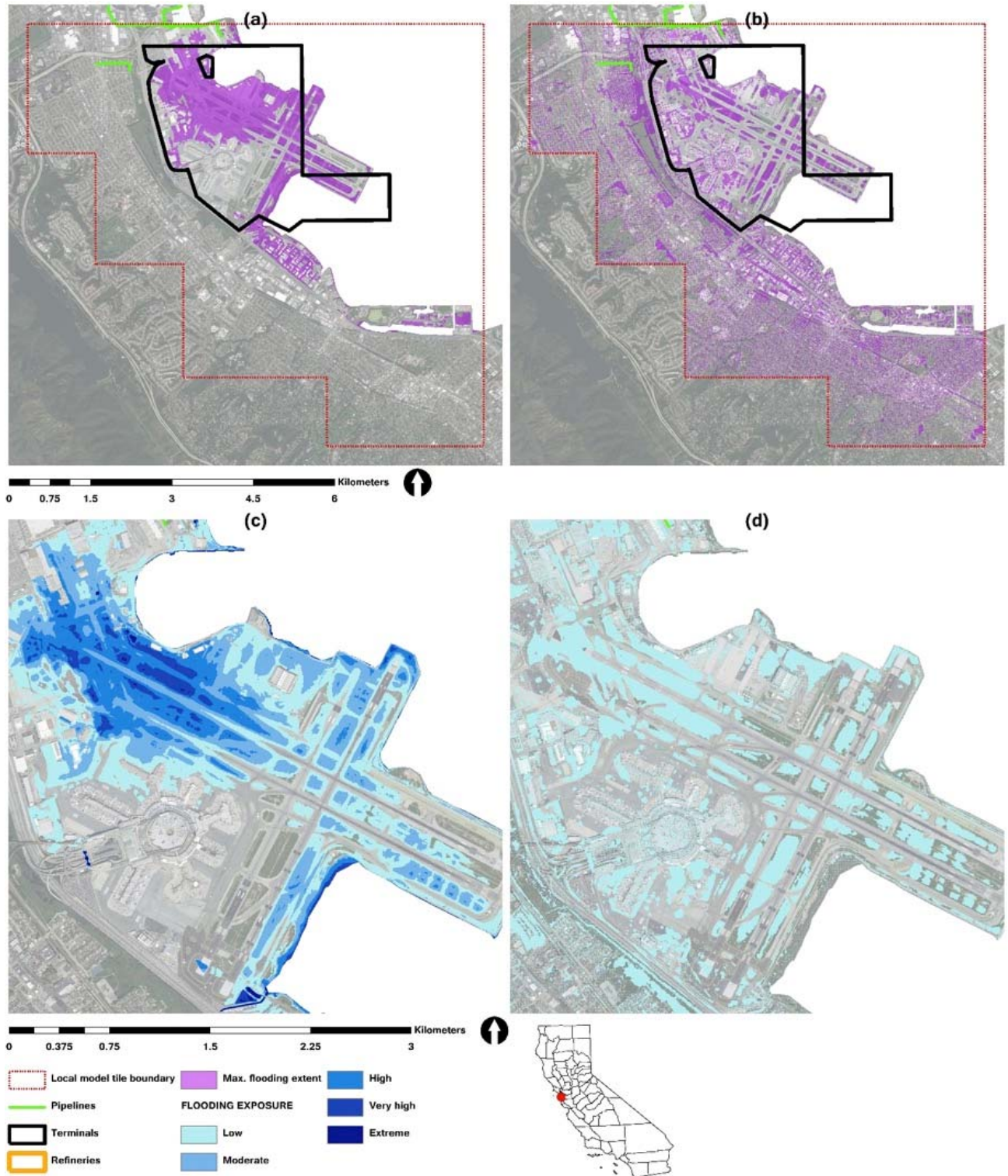

Figure 19. Coastal flooding and inland flooding, illustrated by the median scenario high sea level event and median scenario rainfall event simulated in San Francisco International Airport, Northern California, during the 2020-2040 period. (a) and (b) are maximum extent of the coastal and inland flooding respectively within the modeled boundary. (c) and (d) are zoomed-in maps showing the differences in flooding depth (classified into five exposure classes) between coastal and inland flooding.

In addition, most of the areas we model around the San Francisco Airport remain exposed to low level flooding (**Table 8**), indicating inland flooding may be less an ongoing concern for the TFS compared to coastal flooding in this study area.

Table 8. Coastal flooding versus inland flooding in terms of total exposed area and area by different depth levels, illustrated by the median scenario high sea level event and median scenario rainfall event simulated in San Francisco International Airport, Northern California, during the 2020-2040 period.

Exposure classes (by maximum flooding depth during the events)	Coastal flooding (5 m resolution)		Inland flooding (5 m resolution)	
	Area (km ²)	% in exposed area	Area (km ²)	% in exposed area
Low (0 m – 0.5 m)	1.90	43.89%	4.34	99.91%
Moderate (0.5 m – 1.0 m)	1.41	32.63%	0.00	0.06%
High (1.0 m – 1.5 m)	0.78	18.02%	0.00	0.01%
Very High (1.5 m – 2.0 m)	0.21	4.93%	0.00	0.00%
Extreme (> 2.0 m)	0.02	0.52%	0.00	0.02%
Total exposed	4.32	100.00%	4.35	100.00%

To summarize, we use multi-scenario, multi-temporal, and multi-resolution flooding models to help stakeholders achieve a comprehensive overview of how TFS assets in California are projected to be exposed to coastal flooding induced by sea level rise and storm surge and to inland flooding (in selected areas) induced by rainfall. Our coarse-resolution projection shows that increased proportions of TFS assets statewide are exposed to coastal flooding, particularly deeper levels of flooding, between now and 2100. Refineries, terminals, and docks are the most exposed assets to coastal flooding due to their geographic concentration in coastal zones.

The coarse-resolution coastal flooding model also sparked discussions with the stakeholders to identify a list of areas and time horizons to conduct fine resolution models that better inform the flooding potential at the asset level. The areas of concern identified include Concord, Martinez, Richmond, Stockton, Brisbane, and San Francisco International Airport in Northern California, and Los Angeles/Long Beach Port and San Diego in Southern California. Stakeholders are also more interested in the 2020-2040 period, which better fits with their near-term planning and investment circles. The fine resolution models of coastal and inland flooding help the stakeholders to visualize the future flooding at the level of their own assets and further inform their decisions.

3.2.2 TFS Assets Exposed to Wildfire

The California TFS faces a very real threat of exposure to hazardous wildfire events. The establishment and maintenance of sector resiliency relies upon an understanding of where and when potentially destructive wildfires are likely to occur. This section sheds light on the characteristics of present-day and future wildfire threats and trends in the State.

We conduct this assessment of TFS exposure to wildfire at two spatial scales. In sections 3.2.2.1 and 3.2.2.2 we present outputs from a linked probabilistic model for estimating the amount of area burned by large (> 400 ha) wildfires during past and future periods. This regional scale (16th degree latitude x 16th degree longitude spatial resolution) wildfire forecasting model was generated by Dr. Anthony Leroy Westerling of UC Merced to support Fourth Assessment research projects and is sensitive to changes in climate as well as population growth driven modifications of land cover over time. We, in turn, use these projection data to determine which TFS node and link types have an elevated likelihood of being exposed to the potentially disastrous impacts of large wildfire events during 5 separate 20-year planning periods that span between 2000 and 2100. TFS node and link containing areas deemed likely to face chronic exposure to hazards associated with large wildfire events are examined using a fine-resolution (5 m² or 16.4 ft²) approach to potential wildfire behavior modeling. Our approach to modeling physical characteristics of wildfires burning under specified conditions at a fine spatial scale of analysis is described in Section 3.2.2.3. Information and models outlined in the aforementioned subsections of 3.2.2. can be used by TFS stakeholders to identify trends in exposure to wildfire during multiple future planning periods and to develop targeted risk mitigation strategies that increase the resiliency of the Sector as a whole.

3.2.2.1 Exposure of TFS Assets to Large Wildfire

We evaluate the exposure of individual TFS node and asset types to large wildfires for specific periods of time using a Modeled Wildfire Threat Rating (MWTR) system we develop from the outputs of a probabilistic wildfire forecasting modeling effort put forth by Westerling (forthcoming). Our assessment of changes to large wildfire patterns throughout California between present and future twenty-year planning periods takes into account results from all wildfire projection scenarios modeled by Westerling. We reduce the total number of prediction sets from 240 to 24 by employing average estimates of area burned by wildfire annually across the ten stochastic variations of each unique population growth scenario modeled during the construction of the MWTR system. See Appendices B and D for detailed descriptions of GCMs, RCPs, and population growth scenarios used to estimate changes in land use and land cover (LULC) over the prediction period and to generate inputs to the Westerling large wildfire forecasting models.

The MWTR is a classification system that describes the relative threat of large wildfire occurrence throughout California over the remainder of the twenty-first century. MWTR class labels include “Little to None or Unassessed,” “Low,” “Moderate,” “High,” “Very High,” and “Extreme.” The upper and lower bounds of these MWTR classes are defined by the 2nd, 26th, 50th, 75th, 90th, 99th, and 100th percentile break values, respectively, for Westerling’s modeled estimates of area burned by large wildfires during a 2000-2020 reference period (**Table 9**). We recognize the ambiguity contained within the “Little to None or Unassessed” MWTR class; however, separating the assessed areas with very small estimates of area burned by large wildfire from the unassessed areas is challenging. The difficulty in doing so stems from the fact that Westerling’s wildfire forecasting models do not always produce a numerical estimate for area burned by wildfire at every time step and at every location. The vegetated proportion of each prediction cell can vary over time and between future climate and population growth scenarios modeled. If the vegetated fraction of a prediction cell becomes too small to support a large wildfire occurrence, a null estimate may be output from the model and the cell would be classified as unassessed at that time step even if a wildfire was predicted to occur in that same cell during some other time step. In places where this sort of complication arises out of the

wildfire forecasting model's design, drawing a clear distinction between what qualifies as assessed versus unassessed proves problematic. Refer to Appendices B and D for more information on the complexities of Westerling's large wildfire forecasting models.

Those who work with wildfire related risk may draw comparisons between our MWTR system class labels and those belonging to the National Fire Danger Rating System (NFDRS), which is widely used by state and federal wildland fire management agencies to inform the public of wildfire threat levels and to allocate fire management resources geographically. However, the NFDRS system characterizes the threat of wildfire during very short windows of time and does not forecast changes in wildfire threat over the long-term planning period we investigate in this study (i.e. from present day until the year 2100). For additional background on the NFDRS, refer to Appendix D.

To illustrate how the MWTR can be used to better understand projected changes in the pattern of area burned by large wildfire over time and throughout the State, consider a climate change scenario where the total proportion of California with an "Extreme" MWTR classification increases between the 2000-2020 period and the 2080-2100 period. Change in this direction indicates that estimates equal to or greater than the top one percent of median estimates of area burned by large wildfire during the reference period (2000-2020) are expected to become more common within California by the end of the century. Now consider an instance where a single 16th degree latitude x 16th degree longitude wildfire forecasting cell has its MWTR classifications transition from "Moderate" to "Very High" during the length of time that spans between the 2000-2020 reference period and the 2080-2100 future planning period. In this situation, wildfires occurring in the predication cell being considered would be expected to experience an area burned by large wildfire that was greater than or equal to the statewide 75th percentile central tendency estimate among all scenarios modeled by Westerling during the reference period. For more information on inputs to the MWTR system or the exact reference period percentile break values used to construct the MWTR class definitions and analyze localized trends in exposure to wildfire over time, refer to Appendix D.

Table 9 Modeled Wildfire Hazard Rating (MWTR) level definitions. Percentile break values used in Class Definitions were determined by examination of pooled estimates that include modeling outputs from all four GCM and two RCP permutations recommended for use by agencies managing the development of California's Fourth Climate Assessment.

Modeled Wildfire Threat Rating Class	Class Definition for the 2000-2020 Reference Period <i>Note: Median MEV falls within the specified percentiles of the distribution for all GCM and RCP models combined</i>
<i>Little to None or Unassessed</i>	< 26
<i>Low</i>	≥ 26 and < 50
<i>Medium</i>	≥ 50 and < 75
<i>High</i>	≥ 75 and < 90

<i>Very High</i>	≥ 90 and <99
<i>Extreme</i>	≥ 99 and <100

Modifications to current wildfire patterns over time are expected to be largely driven by changes in land use and wildland fuel stocking levels as well as by fluctuations in local climate and weather conditions. Our MWTR results, shown in

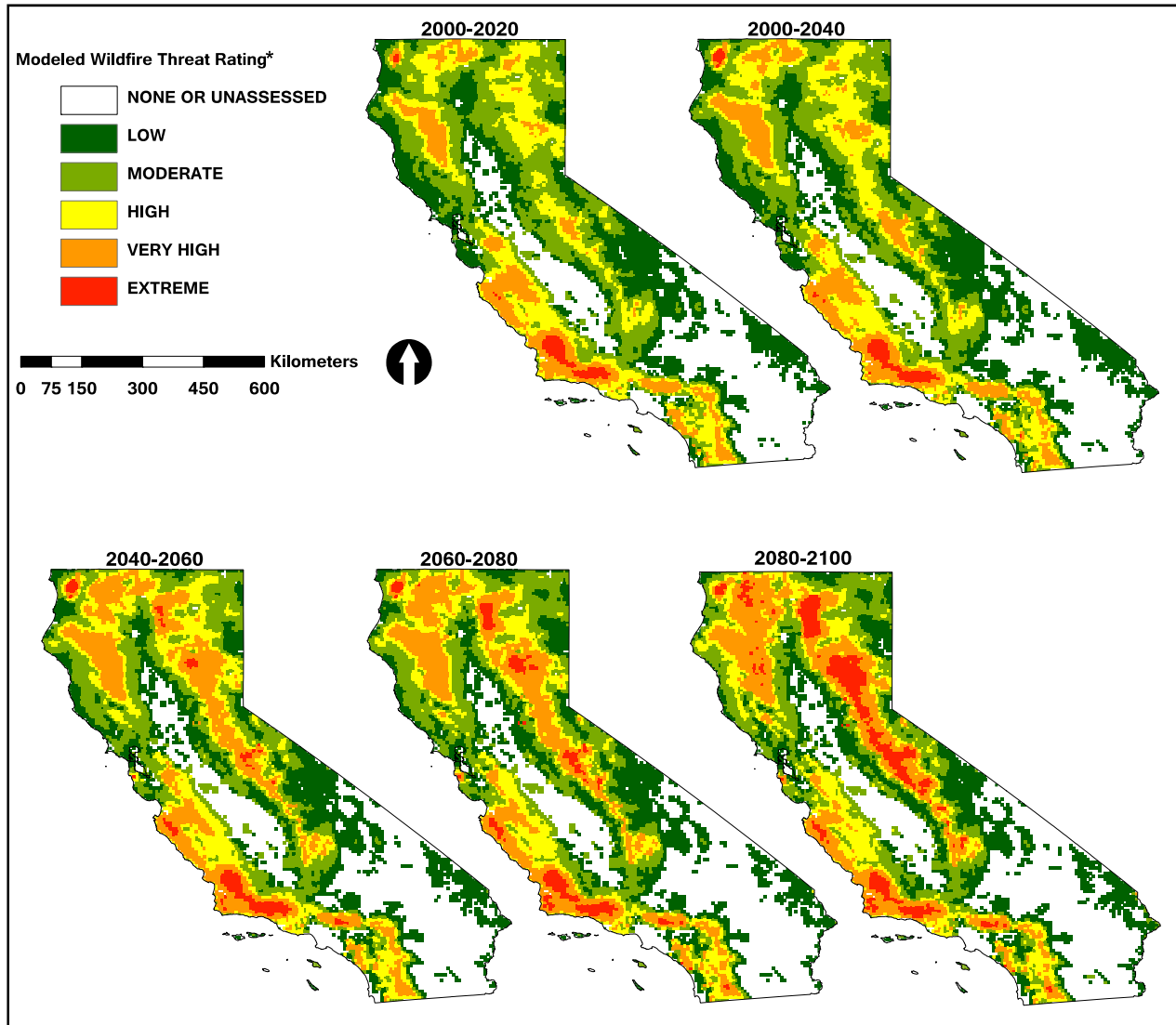

Figure 20, imply that the Extreme, or 99th percentile or greater, estimate of area burned by wildfire currently is predicted to become more common throughout many areas of the State during future periods. Mountainous portions of the State (e.g. the Southern Cascades, the Sierra Nevada, the Central Coast Ranges, etc.) should see the greatest relative increases in area burned by large wildfire events as 2100 approaches. Decreases in the threat of large wildfire are projected to occur within some TFS asset-containing regions of California where urban development (e.g. in portions of the Los Angeles basin or the San Francisco Bay area) or agricultural expansion (e.g. in portions of the Great Central Valley) are expected to increase during remainder of this century. Development tends to replace combustible landcover types

with non-combustible impervious surfaces and built structures that are more susceptible to urban fire than wildland fire. However, the introduction of irrigated and non-irrigated crops typically replaces naturally occurring vegetation types with less combustible cultivated vegetation types and thereby reduces the threat of large wildfires simply because there is not enough fuel present to support the establishment of large wildfire incidents. Although the threat of large wildfires may diminish when these types of changes in land use and land cover occur, it is important to recognize that pockets of fuel remaining in parks, greenways, etc. can support smaller sized incidents when the same conditions that increase the probability of large wildfire occurrence present themselves.

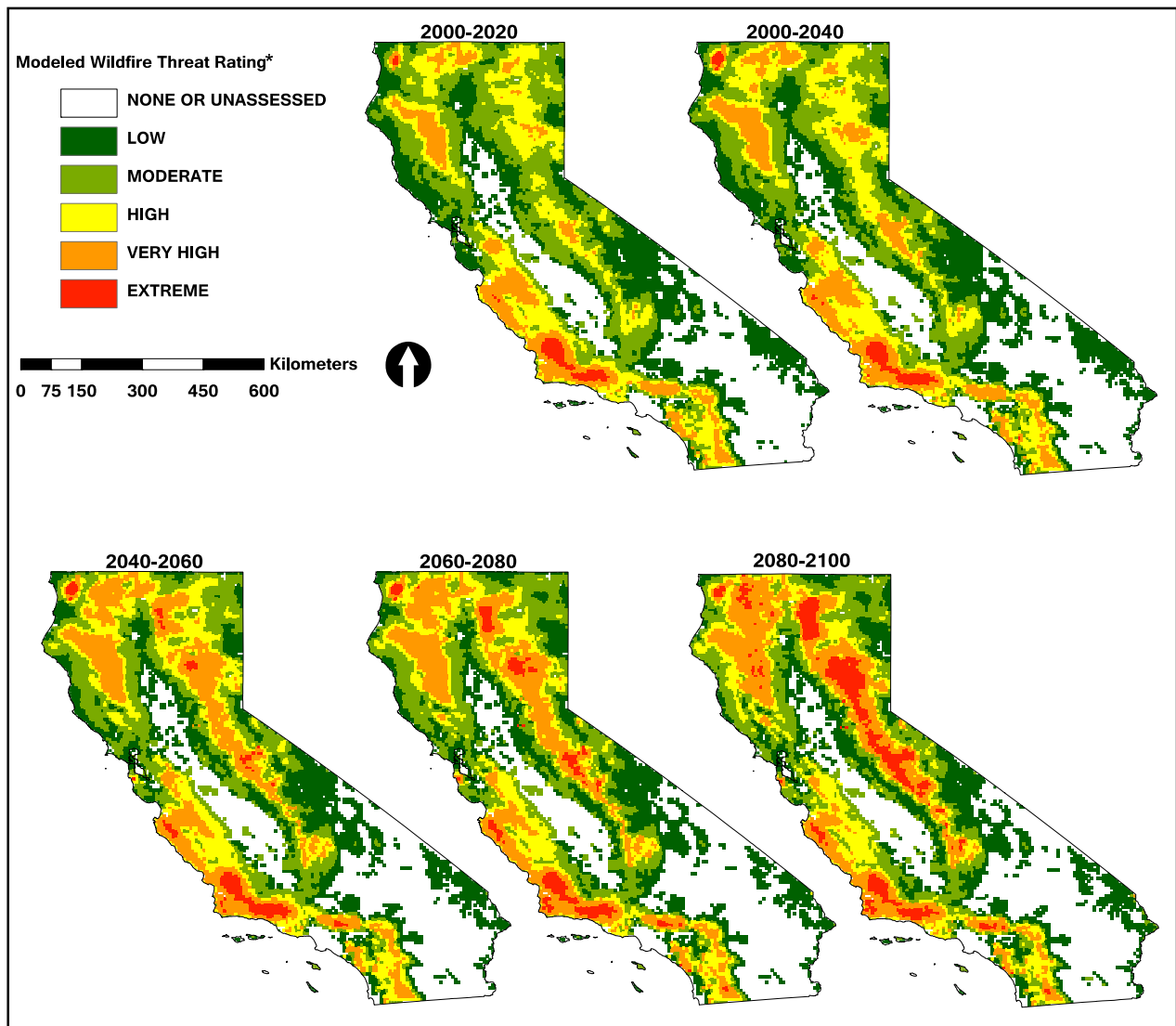

Figure 20. Modeled present-day and future Wildfire Threat Ratings (MWTR) for twenty-year planning periods falling between 2000 to 2100. The pool of values from which median estimates of area burned by wildfire annually for each prediction cell and 20-year period were found included modeling outputs from all 240 wildfire projection scenarios modeled by Westerling (forthcoming). A statewide

distribution of median estimated values from the 2000-2020 reference period were then used to construct the MWTR class definitions.

3.2.2.2 Exposure of TFS Assets to Present-day and Future Wildfire Threats Using MWTR

For TFS link assets, including pipelines, roadways, and railways, we define exposure to wildfire as the length and percentage of the individual asset type intersecting the different MWTR classifications. TFS node asset types such as refineries, terminals, airports, oil wells, and hydrogen stations, as well as gas stations, are represented as points and assessed as counts exposed to each MWTR class. We do not assess changes in MWTR for dock or port TFS asset types, as is done in the flooding portion of this study, because trends in large wildfires occurring in highly developed and water-rich areas of the State where these TFS components are located are difficult to characterize using the Westerling wildfire forecast data. For more information on all asset types assessed as well as data sources used to build the GIS layers for each asset type, refer to Appendix A.

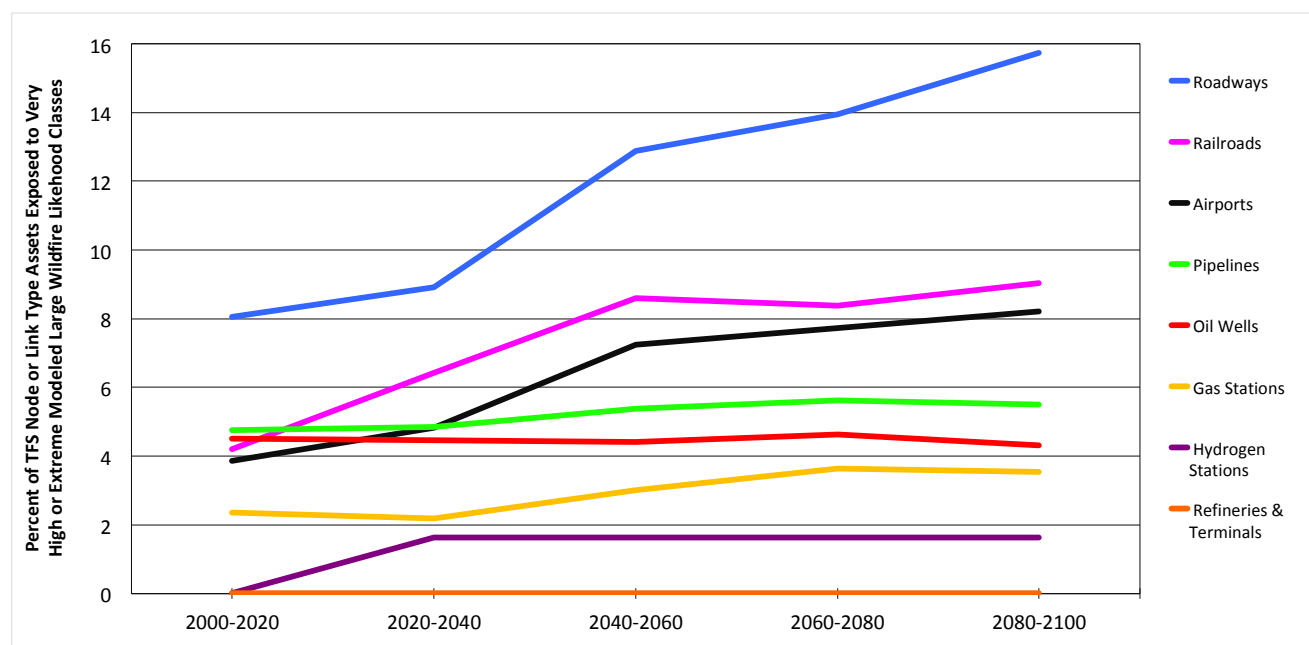

Figure 21. Percentages of each TFS asset types exposed to Very High or Extreme MWTR classes during each 20-year period of analysis. Note that refineries and terminals carry no Very High or Extreme MWTR exposure during the entire 100-year timeframe assessed and thus are not shown in the chart (they have slopes of zero and intersect the y-axis at zero).

During the 2000-2100 period, our results show marked increases occur in the percentages of roadways (+ 8% of total length), railways (+ 5% of total length), and airports (+ 4% of total count) that intersect areas of the state with MWTR classifications that are Very High or Extreme (Figure 21). We find lower magnitude increases in the percentages of pipelines (+ 1% of total length) and gas stations (+ 2% of total count) with exposure to the two most severe MWTR classes during the same timeframe. Oil wells show a slight decrease (<1% of total count) in

exposure to Very High or Extreme MWTR classes while refineries and terminals carry no Very High or Extreme MWTR exposure during the assessment period.

The majority of each TFS asset type is below the 90th percentile (less than very high) median estimate for area burned by wildfire annually during the reference period (2000-2020). Many TFS asset containing regions of the state are projected to carry Low, Moderate, or High MWTR throughout the 21st century and still have potential to be exposed to large wildfire events (**Figure 22**). Terminals and refineries are exposed to very small amounts of large wildfire relative the other asset types. However, the threat still exists and is projected to persist.

■ Low ■ Moderate ■ High ■ Very High ■ Extreme

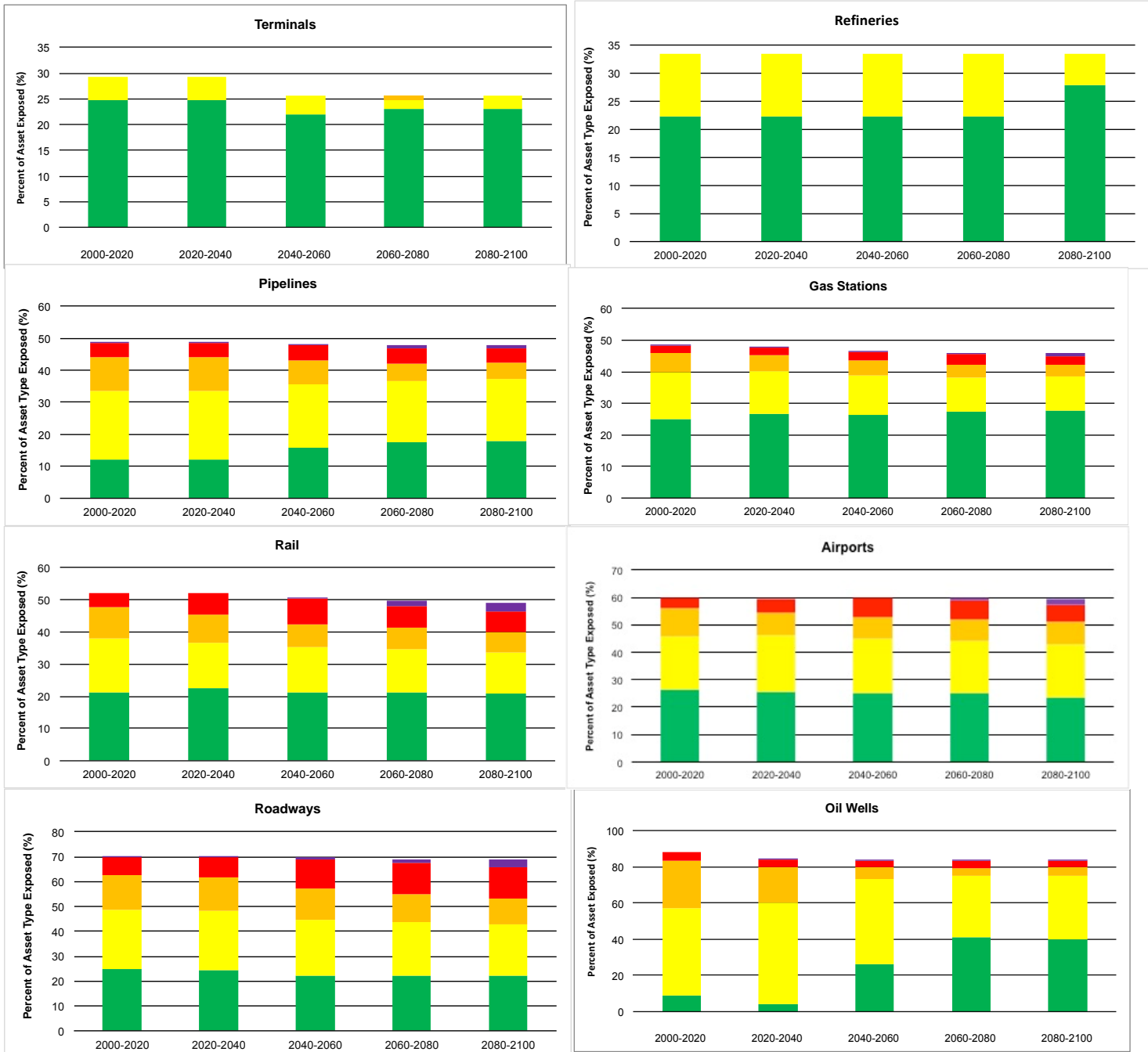

Figure 22. Percentage of each TFS asset type exposed to each MWTR class.

3.2.2.3 High-resolution Wildfire Behavior Modeling

High spatial resolution (5 m, 16.4 ft) wildfire behavior modeling reveals the current exposure of TFS assets to wildfire hazards. Locations identified as Very High and Extreme by the MWTR

system were examined at the asset scale and modeled under catastrophic wildfire conditions. For TFS asset managers, the benefits of identifying current wildfire hazards include assessing over time periods and at locations already relevant to them, their own vulnerabilities and damage scenarios, developing targeted risk mitigation strategies, and preparing for wildfire events where firefighters cannot control wildfire around the asset.

Our high-resolution modeling approach uses three wildfire behavior metrics to quantify wildland fire hazards: fire intensity (British Thermal Units (BTU)/square ft, heat per unit area), flame length (ft), and rate of spread (ft/minute). Each of these metrics describes a wildfire behavior as a different type of hazard, which is useful in examining different forms of direct wildfire exposure and differentiating the impact on different assets. Fire intensity indicates heat emitting potential of a wildfire per unit area. Flame length, according to the National Wildfire Coordinating Group (NWCG) (2014), measures “the distance between the flame tip and the midpoint of the flame depth at the base of the flame (generally the ground surface),” and is an indicator heat emitting potential and fire propagation potential. NWCG (2014) defines rate of spread as “the relative activity of a fire in extending it’s horizontal dimensions.” For further description of these wildfire behavior hazard metrics, see Appendix D.3.4.1.

The regional scale wildfire analysis found that highways, railways, and pipelines are and will continue to be the primary TFS assets exposed to wildfires. These asset types have different vulnerabilities to wildland fire and certain wildfire behaviors metrics are more important to some managers than others to ensure that damages and disruptions do not occur. For example:

1. Trucks may be stopped due to high flame lengths that extend into roadways. Proximity to tall, flammable trees falling into roads and traffic are a highway-specific vulnerability.
2. Railways share similar vulnerabilities to roadways. Moreover, railroad rails may warp from thermal expansion when exposed to high heat intensities or may have wooden ties that ignite. Heat capacity and type of rail tie are rail-specific vulnerabilities.
3. Pipelines are often buried and insulated but have above-ground appurtenances susceptible to exposure. Belowground infrastructure may be damaged during wildfire suppression activities when emergency response equipment (e.g., D9 bulldozers) dig up soil to create fuel breaks. Depth of underground pipelines and quality of insulation are pipe-specific factors of vulnerability.

A more general application of wildfire behavior metrics is used in assessing the degree to which wildland firefighters can control a wildfire. Based on existing wildland firefighting protocols, fire behavior that exceeds a specific threshold value changes how wildfire suppression is approached. Assets exposed to high and extreme metric values may indicate wildfires are out-of-control or nearly so, leaving assets unprotected during these events.

We measure the direct exposure of TFS assets to wildfire as the proximity of modeled fire behavior hazards to a specific asset. Each asset has an exposure profile that describes the distribution of wildfire behavior characteristics within 304.8 m (1000 ft) of the asset.

These characteristics do not consider indirect wildfire threats, such as duration of fire, soil instability, mudslides, and damaging wildfire suppression activity. Similar to threats from direct heat exposure, indirect wildfire threats to TFS assets are also asset-specific. A more comprehensive wildfire exposure assessment would consider indirect wildfire effects in order

to better understand the relationships between wildfire exposure, potential damages and system-wide TFS disruptions.

A Case Study of Dutch Flat

Figure 23 shows an example of high-resolution wildfire modeling in a forested region of northern California, Dutch Flat, which we identify as having an increasing frequency of large wildfires from 2018 until 2100. In the town of Dutch Flat, there is a convergence of three TFS assets: highway, railway, and pipeline.

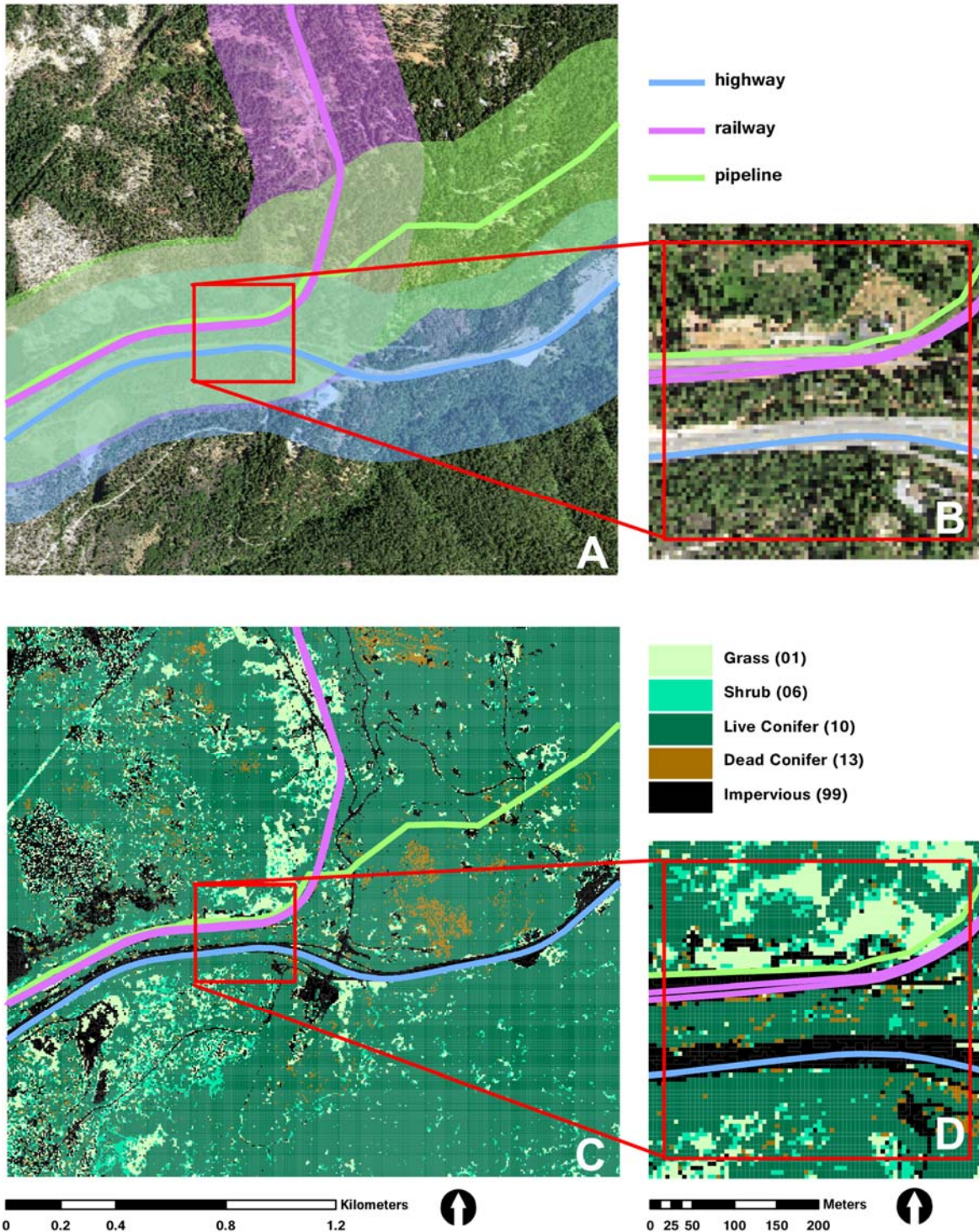

Figure 23. Convergence of TFS link assets and land cover surface used in high-resolution fire modeling. a) is a NAIP image with TFS link assets and their respective 1000' buffers for assessing exposure to fire hazards. b) is a close up of the NAIP image at the convergence area. Note the pixelation of the image. c) is the land cover surface (see Appendix D 3.8 for details) and d) is the landcover surface zoomed in to match the area of b.

Figure 25, Figure 27, and Figure 29 describe asset exposure to wildfire hazard within a buffer around each asset. The convergence of TFS assets in Dutch Flat represents a high-risk location for the TFS, where the assets have a disproportionate amount of exposure to high and extreme hazards combined. **Figure 25, Figure 27, and Figure 29** show a distribution of wildfire behaviors by asset type.

Figure 26, Figure 28, and Figure 30 illustrate how fire behavior is variable across the landscape, affected by factors such as slope, aspect, elevation, fuel type, and canopy cover. Such figures are increasingly useful, we argue, for developing targeted risk mitigation plans and informing fire suppression strategies. The Fire Characteristics Chart below (**Figure 24**), also known as the “Hauling Chart”, indicates how fire behaviors may impact fire suppression. For additional discussion on the modeling process, refer to Appendix D Sections 3.3, 3.4, 3.5, and 3.6.

SURFACE FIRE BEHAVIOR Fire Characteristics Chart

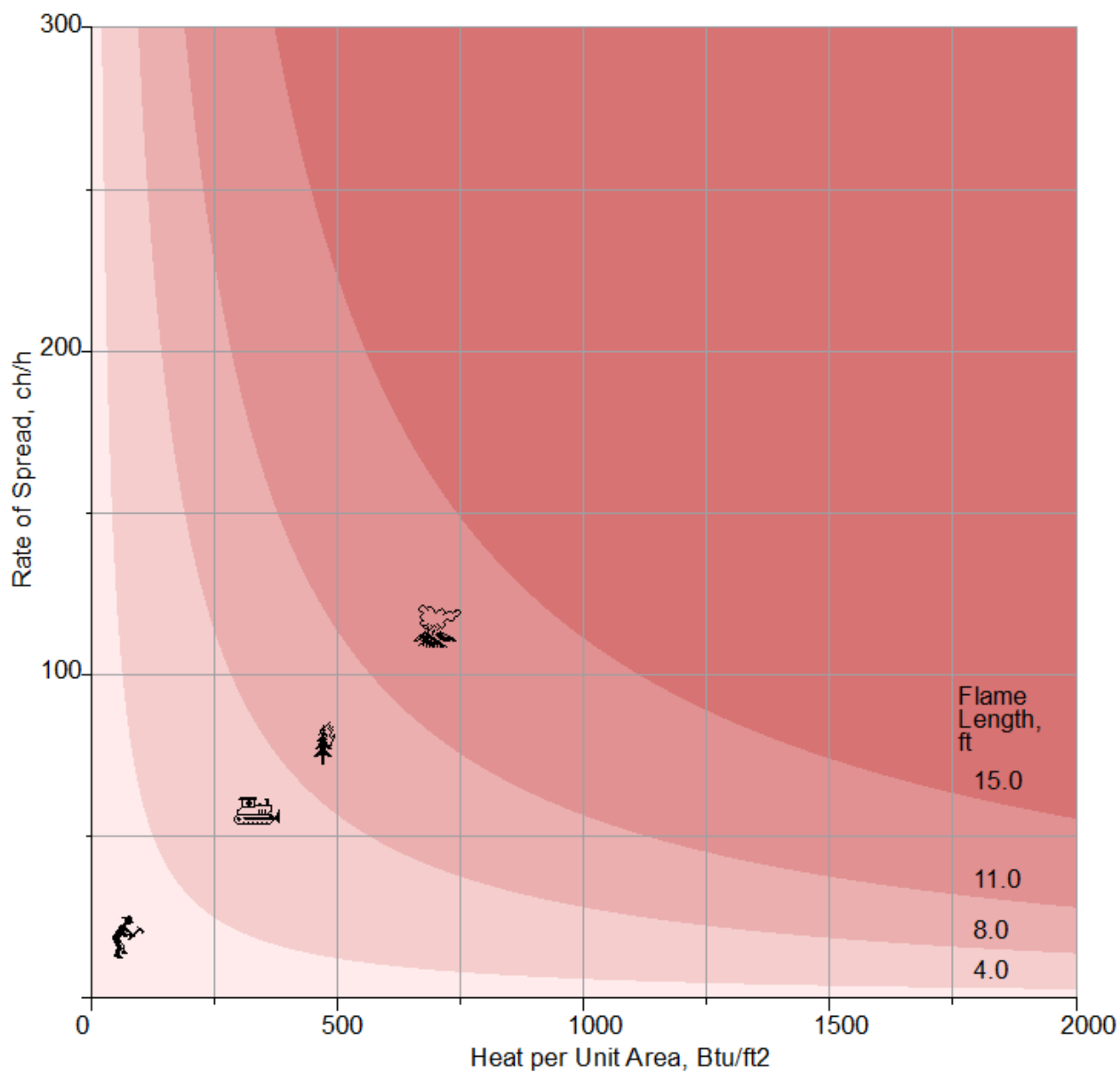

Figure 24. Hauling Chart (Andrews, Heinsch, & Schelvan, 2011): On this graph are our three modeled fire behaviors, rate of spread, flame length, and fire intensity (heat per unit area). The zoned areas from the lower left corner, diagonally up and to the right, are the expected fire suppression methods and behaviors expected. At the lowest flame length class, hand tools will primarily be used in fire suppression. The next region indicates potential use of mechanical suppression methods. The next class denoted by the burning tree indicates potential for a canopy fire. The final classes indicate extreme wildfire behaviors, where spotting and indefensible space are expected.

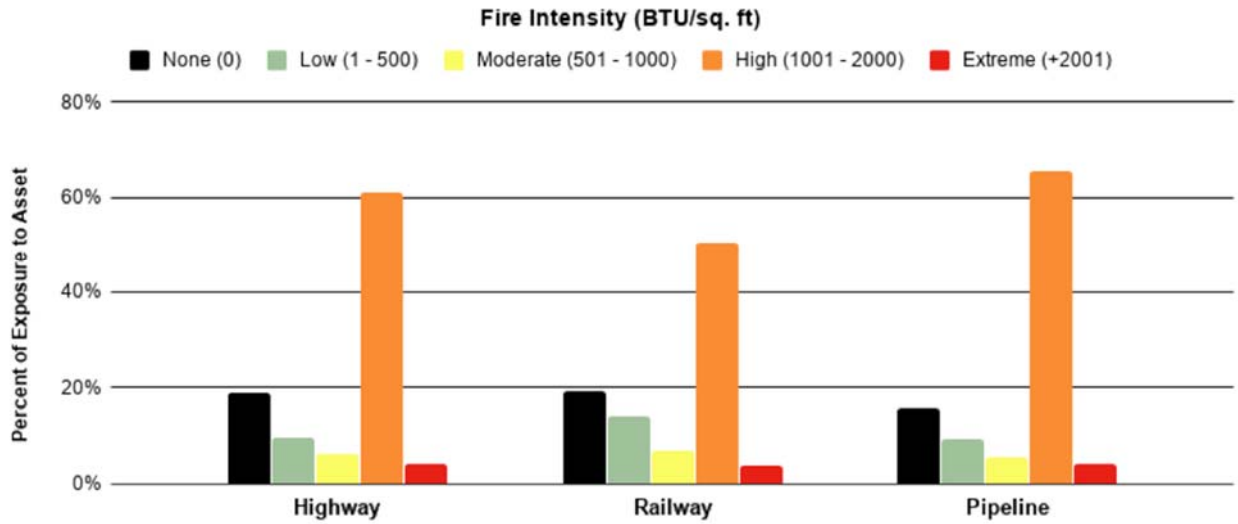

Figure 25. Modeled fire intensity estimates for each asset type as percent exposure to each wildfire behavior threshold at Dutch Flat.

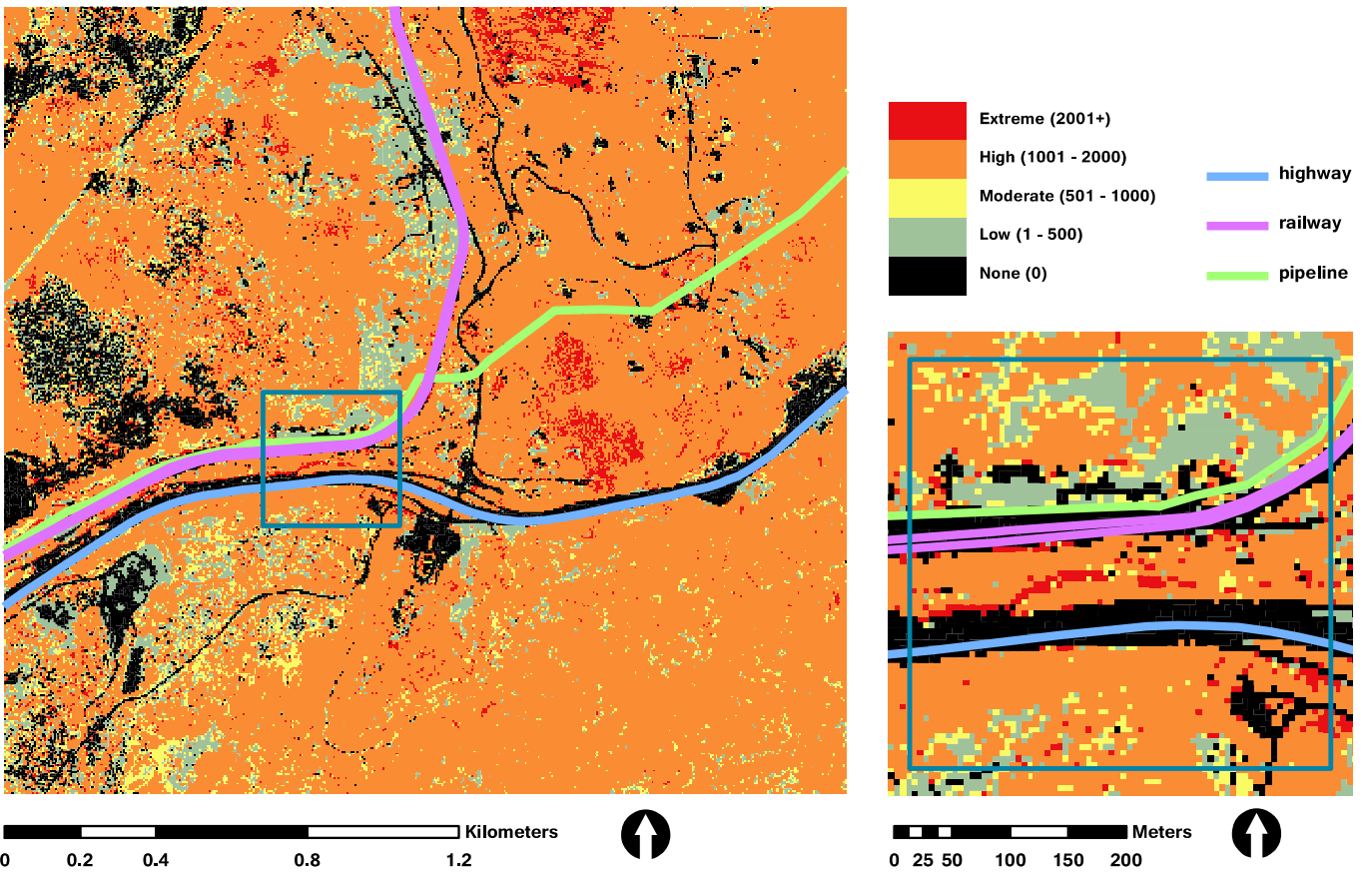

Figure 26. Fire intensity modeled across the Dutch Flat landscape.

The proportion of high fire intensity is expected due to the high density of tree cover. Where the assets converge in the zoomed-in image (Figure 26), the pipeline and railway have a relief due to the bordering grass patch just north of the assets. However, the south side of the rail is bordered by areas of high and extreme fire intensities that threaten northbound rails. Rail infrastructure is vulnerable to fire intensity because rails can be damaged by thermal expansion from direct wildfire exposure. While the pipeline asset has the greatest exposure to high fire intensities (Figure 25), it is less vulnerable because it is buried and less sensitive to surface fire exposure, unless there are any aboveground appurtenances in this area. From stakeholder discussions, we know TFS pipelines are generally three feet belowground. Preisler et al. (2000) shows that heat fluxes from smoldering vegetation decrease significantly centimeters beneath the surface. We infer that pipelines at depths of three feet or deeper are not significantly exposed to high- and extreme-intensity surface fires. However, pipelines nearer to the surface may have greater exposure. Highway segments are composed of wildfire resilient materials, such as concrete and asphalt. While these materials may be less vulnerable to wildfire damages, wildfire has in the past produced disruptions with forced lane closures or segments of highway being shut down until an active wildfire is suppressed. The broader implications for safe and reliable TFS transportation in such areas are considerable.

The spatial distribution of high and extreme fire intensity measures across Dutch Flat indicate that firefighters may not be able to control a wildfire near these assets (see Figure 24). This is a concern for this TFS asset convergence because it may allow these hazards to materialize in the event of a nearby wildfire, and moreover, cause system-wide disruptions.

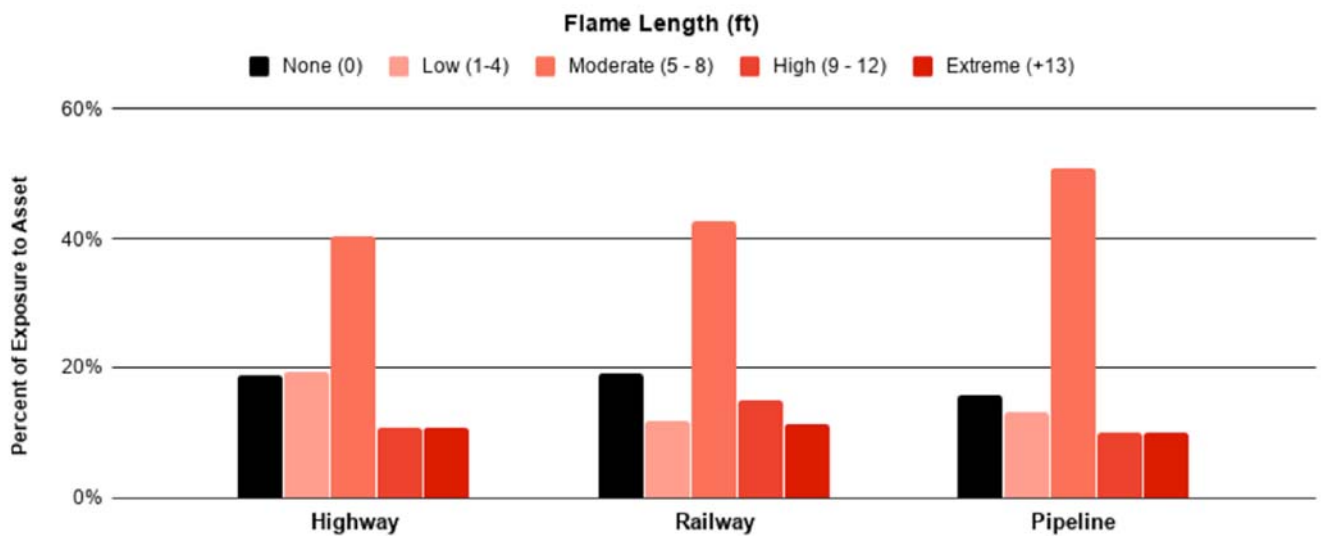

Figure 27. Modeled flame length estimates for each asset type as percent exposure to each wildfire behavior threshold at Dutch Flat.

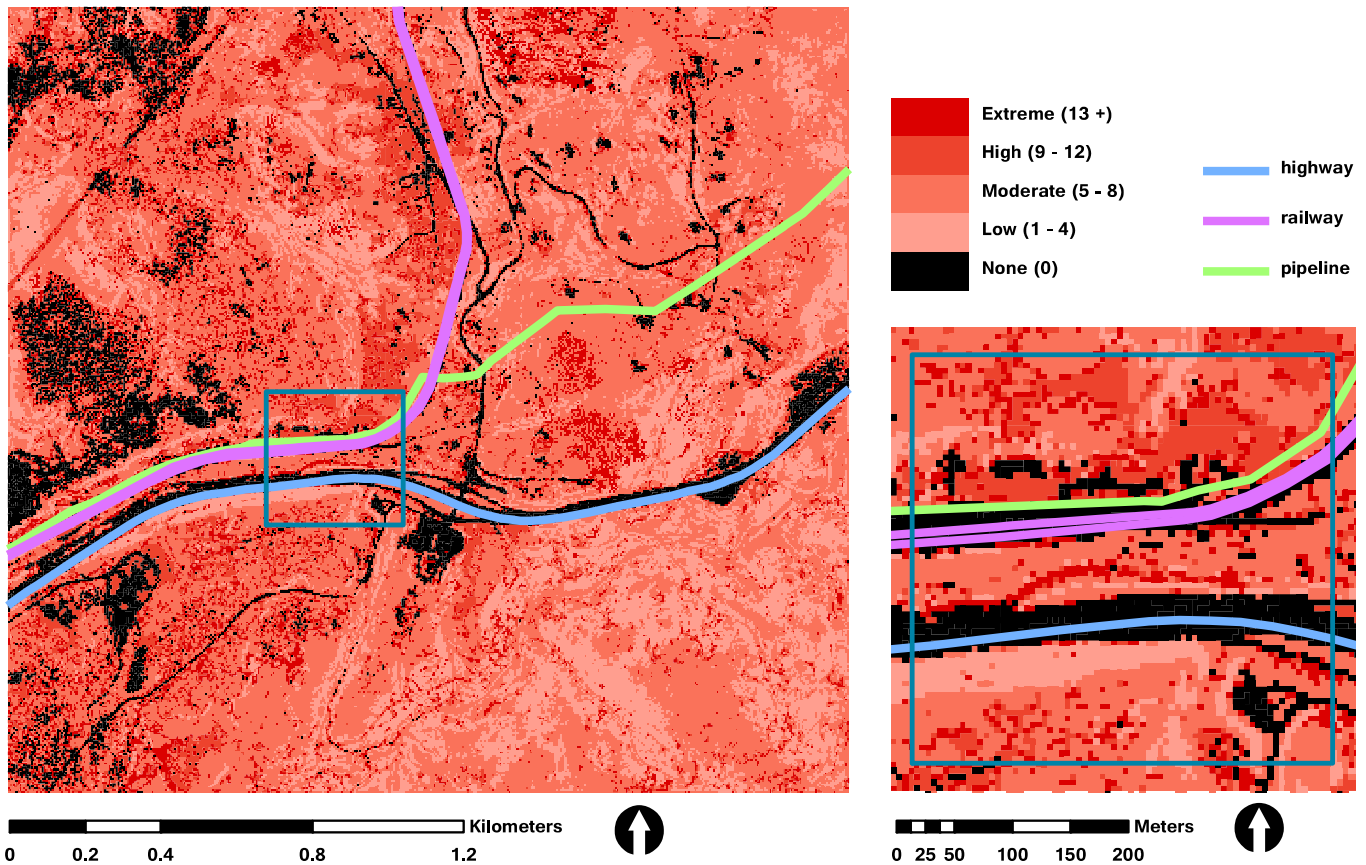

Figure 28. Flame length modeled across the Dutch Flat landscape.

Flame lengths are strongly influenced by slope steepness, wind, and fire intensity. At the point of asset convergence (**Figure 28**) a large proportion of high and extreme flame lengths are evidently due to the very steep slope and dense pine trees bisecting the highway from the railway and pipeline.

Flame length affects all aboveground assets similarly and is useful to understand the distance between flames and the asset. To our knowledge, flame length has not been a reported concern for belowground assets, but presents serious concerns for assets like railways, which may be damaged by direct flame contact.

Firefighters use flame lengths (see **Figure 24**) as the primary indicator to inform their control strategies. When flame lengths are high and extreme, firefighters likely will retreat to a secure location where they can suppress the flames, allowing the asset to be compromised.

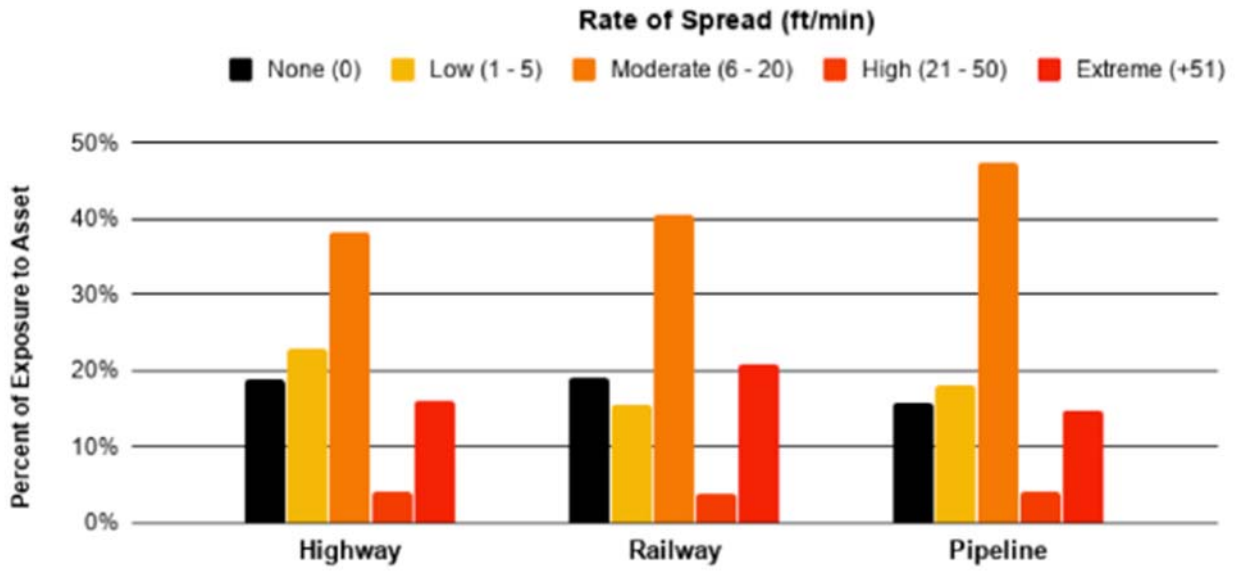

Figure 29. Modeled rate of spread estimates for each asset type as percent exposure to each wildfire behavior threshold at Dutch Flat.

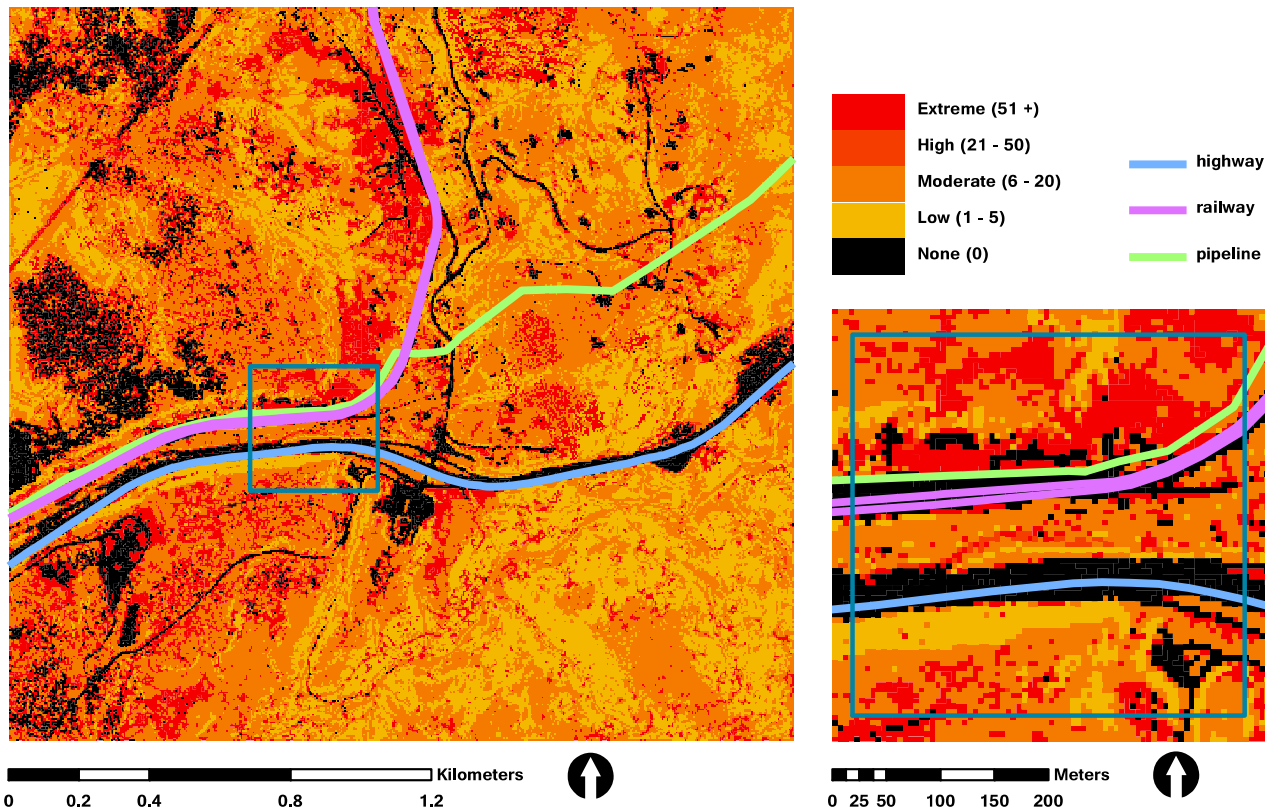

Figure 30. Rate of spread modeled across the Dutch Flat landscape.

In the event of a nearby wildfire, assets exposed to high and extreme rates of spread face a higher likelihood of a proximal ignition. Rate of spread is strongly influenced by slope steepness, wind, and fuel type. Grasses are light, flashy fuels that are known for having high rates of spread. High and extreme rates of spread may jeopardize a firefighter's ability to contain an expanding fireline.

High resolution modeled wildfire hazards can be used to manage the direct exposure of wildland fire to assets by informing wildfire adaptation strategies. This includes targeted vegetation management, implementing wildfire fuel breaks, and hardening infrastructure. Vegetation management strategies and fuel break implementation can be modeled by applying vegetation changes to the digital landscape and can be “re-burned” in a wildfire behavior simulation. High-resolution wildfire modeling can be used to demonstrate proactive wildfire mitigation strategies and to achieve a more desirable level of exposure (See Appendix D.7).

3.2.2.4 High-resolution Wildfire and Tree Mortality Assessment

Recent research by Scott Stephens et al. (2018) reports that tree mortality is becoming more prevalent in California, especially in the northern California Sierra Nevada. The mortality is a result of recent drought, insects and disease, and a human-induced infrequency of low and moderate intensity wildfires. Downed vegetative fuels pose a risk of high and extreme surface fire intensity if ignited (Stephens et al., 2018).

We identify canopy biomass loss in forests using remotely sensed MODIS imagery. We leverage the Enhanced Vegetation Index (EVI) to indicate canopy biomass loss derived from decreases in seasonal peak canopy greenness from 2000 to 2016 (see Appendix D, **Figure D 23**). These are areas of potential concern for high- and extreme-surface fire intensities described by Stephens (2018). We intersect these tree mortality assessments in wildfire prone regions with TFS infrastructure and identify wildfire hazards (see Appendix D, **Table D8**). We find 72 km (44.7 miles) of refined fuel pipeline is exposed to biomass loss and a CalFire high wildfire rotation class. These pipelines are concentrated in the northern California Sierra Nevada and in southern California (see Appendix D, **Figure D 24**). High-resolution tree mortality assessment can be used to demonstrate levels of TFS asset exposure throughout the State (See Appendix D.2.9).

3.3 Measuring Exposure and Impacts Using Networks

It is a truism today that the connections and linkages between and among infrastructure components have increased more and more, promoting the growth of large-scale interconnected systems (Lindner, Burla, & Vallée, 2018). However, this truism merits a closer examination since it is often left unclear whether the new connectivity in question, infrastructure by infrastructure, is more tightly coupled or loosely coupled with regard to potentially cascading interactions. As such, this growing complexity of connected infrastructures across multiple infrastructure networks poses great challenges for evaluation of potential impact of extreme weather events on the entire network, particularly at the sectoral level of the TFS as a whole. Creating a network model is intended to assist in understanding better the possible pathways of the network connectivity and in quantifying the impact of disruptions to the flow within the network.

The TFS is an interconnected complex network regarding both organizational connections and geospatial infrastructure connectivity. The former type of complexity is fully explored in Chapter 2. The latter is evaluated below to better understand TFS network connectivity as well

as the impact of extreme weather events on the flow of fuel between TFS infrastructure assets. Our process involves several steps: (a) data collection of TFS assets in the study area; (b) creation of a comprehensive TFS multimodal network model; (c) identification of critical assets in the network; and (d) evaluation of impact on the fuel supply through routing simulations under different climate scenarios.

3.3.1 A Network Example: Coastal Flooding Case Study in the San Francisco Bay Area

A break in the TFS network can lead to cascading impacts that are far greater than the actual impacted asset. To demonstrate how a particular type of extreme event - coastal flooding - impacts the TFS under our scenario modeling, we choose to focus on a smaller region within the state. The San Francisco Bay Area is chosen because of its high concentration of TFS assets and its high percentage of average flood inundation across all the climate scenarios under which we model coastal flooding.

Our network analysis, in which we measure *betweenness centrality*, underscores that many refineries and terminals along the east coast of the San Francisco Bay are core to topological network connectivity. This means that if they are negatively impacted due to extreme weather event exposure, the network will be disrupted. By way of illustration, we simulate the routes between two distinct pairs of TFS assets which are topologically critical for the TFS. The results show where coastal flooding potentially damages parts of the network and how this leads to rerouting the transfer of crude oil or refined oil products to the specific destinations.

On the left of **Figure 31**, the present-day optimum route used to deliver petroleum products from the Chevron Martinez terminal to the Phillips66 terminal in Richmond is shown. On the right is the “new” route that would be used (in this simulation) due to disruptions on the present-day route caused by coastal flooding, which has mainly flooded the last leg of the present-day route near Richmond. The network analysis model indicates that an alternative route, the rerouting identified in the preceding paragraph, could be used to deliver petroleum product first to a marine terminal and then to the destination via an extra marine route. This would place extra pressure on a marine terminal that is already in high demand. In addition, it would mean that marine routes will need to be more heavily utilized in future flooding events scenarios to successfully complete the oil product transport to the Phillips66 terminal.

Network modeling and analysis can, and we believe should, be done for other locations of California. This would, however, require more detailed information about the interconnected multi-modal network of the TFS, within the state and beyond its borders. More specific information about the flow of crude oil or petroleum products would be needed, and more detailed information would be needed on the actual disruption and its duration caused by exposure to an extreme weather event at specific locations within the TFS.

3.3.2 Steps Towards Network Modeling

We start, as with the flooding and wildfire modeling, by collecting geospatial data for all types of TFS assets within the state in order to build a comprehensive multi-modal network. We then integrate data representing TFS network nodes and links together using NetworkX, a Python language software package for efficient creation and analysis of complex networks (Hagberg, Schult, & Swart, 2008).

In order to understand the critical assets within the TFS in terms of topological network connectivity, we choose metrics from graph theory to calculate network centralities such as betweenness centrality and apply to all nodes within the network.

Betweenness centrality measures how important an asset is in terms of its role as an intermediate stop along all shortest distance routes between two nodes within the network.

Figure 32 illustrates an example result of betweenness centrality calculation for the TFS network in the San Francisco Bay area. In the figure, the larger red circles represent assets with higher betweenness centrality while the smaller green circles represent assets which have low betweenness centrality. To calculate betweenness centrality, we first start with a fully connected network and generate shortest distance routes between all possible pairs of nodes. We store the names of all intermediate nodes and count how many times a particular node appears. If a node appears frequently, then this means that this node is on many shortest distance routes. If this node is removed out of the network (similar to an asset being disrupted due to coastal flooding), then many shortest distance routes within the network will need to be re-routed which might lead to increased cost in time and resources.

The calculation results are integrated with findings from the stakeholder discussions. From this we identify potential critical origins and destinations for network routing simulations. Network routing simulation is a process of generating the shortest distance route between a specified origin and destination. The resulting route can be displayed in GIS; it shows the location of the route, its length, and what types of transportation modes are used along the route. This is useful for examining changes in the routing between two nodes across different climate scenarios and understanding the impact of extreme events on the flow within the network. For further detailed explanation of this network model, please refer to Appendix A.

Up stream Supply Chain: Terminal to Refinery

Up stream Supply Chain: Terminal to Refinery

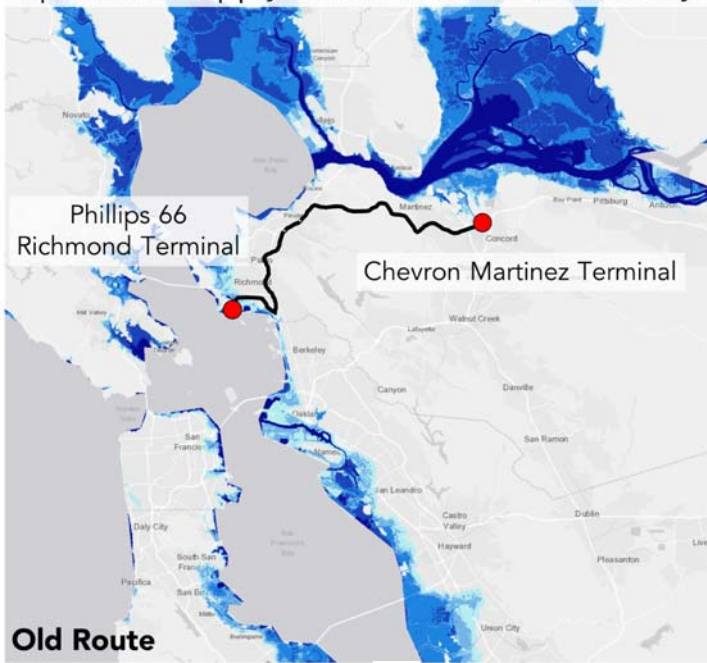

Figure 31. Routing simulation before-after illustrations

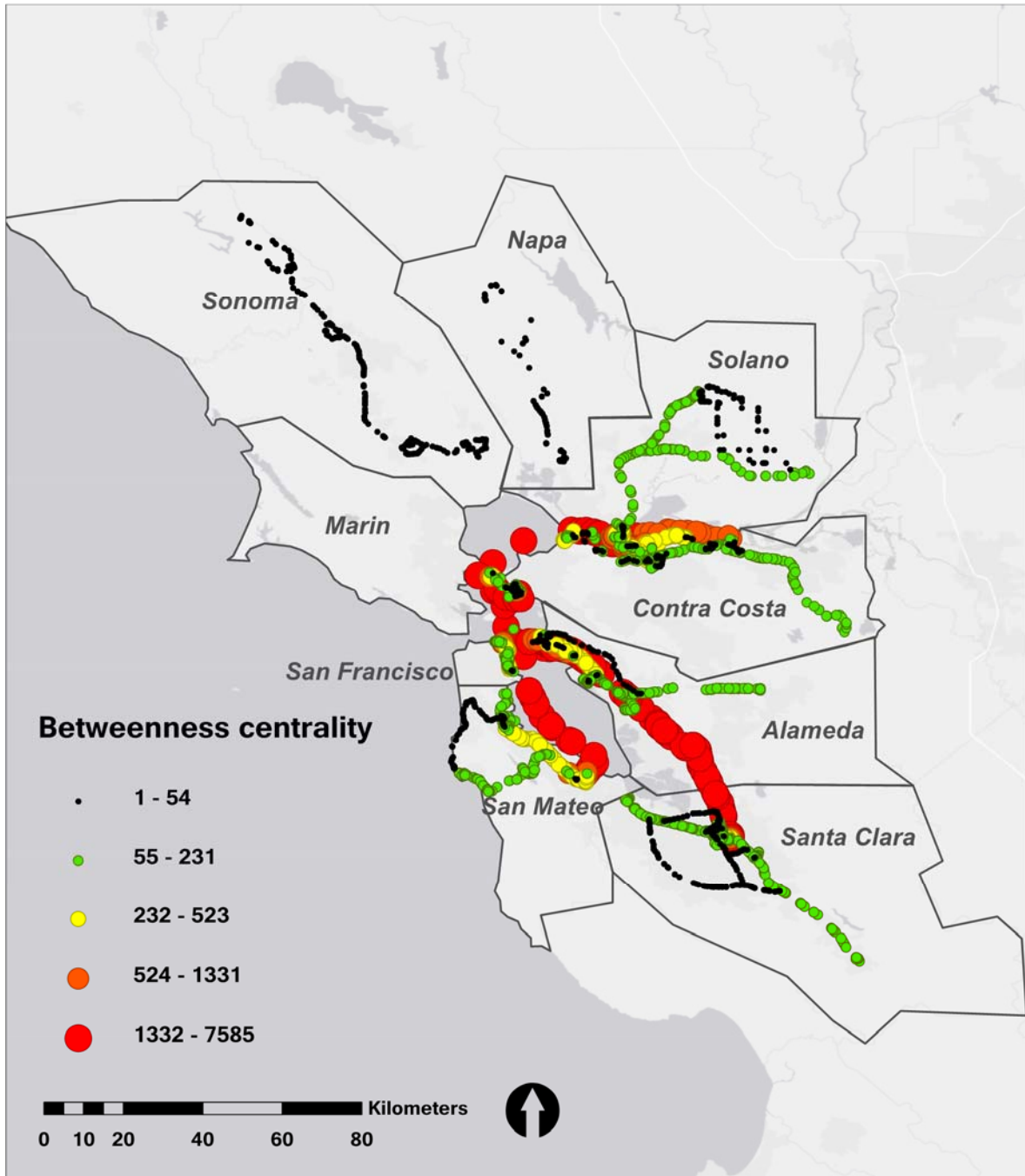

Figure 32. Map of betweenness centrality in San Francisco Bay area

4: Stakeholder Engagement

This chapter describes the stakeholder engagement process. Stakeholder engagement is a critical step to understanding the inherently complex nature of the TFS and the numerous organizations that are key to the reliable and safe distribution and supply of transportation fuel in California. Stakeholders representing organizations throughout the state were involved in this process.

We engage with stakeholders in order to 1) understand the TFS as critical intraconnected infrastructures considering physical and organizational networks (see Chapter 2), 2) link the measured outputs of our exposure models to damage propensity of the stakeholder’s exposed assets and supply-demand chain network, and 3) gain insight into stakeholders’ strategic planning in light of extreme weather-caused events such as flooding and wildfires.

Significantly, the stakeholder discussions provide a picture of the TFS that complements our modeling picture, serving to overlay our modeling results with real-world applications.

4.1 Stakeholder Profile

To gain insight in the TFS and its assets, we engage with a variety of organizations (or their representatives) knowledgeable about the nodes and links identified in our TFS conceptual model (see Chapter 2). Organizations that own and operate key TFS assets are identified as “TFS Core” stakeholders. Stakeholder organizations on which the TFS Core organizations depend are categorized as “TFS Dependent”. The TFS Dependent organizations are owners and operators of services that organizations in the TFS Core rely heavily on, such as water and power; they can also be agencies that regulate TFS-dependent infrastructure. Last, we engage with stakeholders that regulate and research TFS Core organizations. This final group is categorized as “TFS Knowledgeable”. The latter are either regulatory or academic institutions that work directly with one or more key oil and transportation assets, as well as organizations that provide safety and emergency management services to the TFS Core. The organizational categories are shown **Table 10**.

Table 10. TFS Organizational Categories

TFS Core	TFS Dependent	TFS Knowledgeable
<ul style="list-style-type: none"> • Owners/operators • Associations 	<ul style="list-style-type: none"> • Power • Water • Regulators of TFS Dependent infrastructure 	<ul style="list-style-type: none"> • Academic • Regulatory • Safety/emergency management

Our stakeholder outreach follows a purposive sample and snowball engagement technique. The Technical Advisory Committee first helped develop the attendee list for our two workshops. These workshops then led to further discussions. In total, 47 organizations participated in these stakeholder engagement activities and are broken down as follows: 25 TFS Core (out of which

seven correspond to the hydrogen fuel industry, see Appendix F), 6 TFS Dependent, and 16 TFS Knowledgeable.

Within each stakeholder organization, discussion participants provide a range of knowledge and expertise. This enabled us to categorize them according to the information they shared regarding the TFS. We divide the “knowledge pool” into classes to depict specific aspects of the TFS, such as commodity subsystem, key oil infrastructures, key transportation infrastructures, and dependent infrastructure. Further categorization provides insight into the breadth of the representation of stakeholders involved in the engagement process and ensures that each key transportation fuel sector asset is represented. Our breakdown of the knowledge pool classes is summarized in **Table 11**.

Table 11. Stakeholder knowledge pool categories

Class	Subclass
Commodity subsystem	Crude oil
	Refining (all products and gasoil)
	Motor vehicle fuels (gasoline, diesel, biofuels)
	Jet fuels (kerosene, naphtha)
	Marine fuels (marine gasoil, distillate marine diesel, residual oil)
Key nodal assets	Oil fields/gathering stations
	Marine terminals/wharfs/ berths
	Crude rail terminals
	Refineries
	Distribution terminals/Bulk plants/Breakout tanks
	Motor vehicle fuel dispensing facilities
	Airport fuel dispensing facilities
	Marine fuel dispensing facilities
Key linkage assets	Pipelines
	Railway
	Roadway
	Waterway
Dependent infrastructure/ services	Water
	Power
	Emergency management

4.2 Areas and Assets of Concern

To guide our exposure modeling (particularly fine resolution modeling) efforts, we ask stakeholders to identify areas of concern and assets of concern in the context of coastal flooding, inland flooding, and wildfire exposure. In many cases, stakeholders express concern for their own assets when these are directly or obviously exposed to the extreme weather events above. For instance, any infrastructure located adjacent to water is deemed vulnerable to sea level rise or inland flooding, and any asset located near heavy and dry vegetation is deemed vulnerable to wildfire.

Our discussions indicate that the stakeholders we engaged with are more concerned about coastal and inland flooding than about wildfires, and their concerns are more focused on their own assets than intraconnected ones. However, stakeholder level of concern for coastal flooding decreases if their assets are located well above sea level, even when their assets are connected to other key TFS infrastructure close to water. In like fashion, wildfires are mainly of concern to stakeholders whose assets are either in close proximity to vegetation or near areas that previously underwent large wildfires. The assets of concern to stakeholders in our discussions include refineries, various forms of transshipment intermediate terminals (marine terminals, petroleum docks, distribution terminals, and petroleum bulk plants or card lock facilities that are specific to trucking companies), as well as product pipelines and their pumping stations.

Pipelines are generally not perceived by stakeholders as being at risk of exposure when they are buried underground or have protective steel encasements. During our discussion with stakeholders, we present historical burned areas that overlapped with their assets. Pipeline stakeholders report that there have been no disruption incidents from these historical wildfire events, except for infrequent low consequence impacts on aboveground appurtenances such as pumping and valve stations. The vulnerability of pipelines is predominantly discussed by pipeline stakeholders in the context of wildfire emergency response activities and excavation strikes from fire suppression techniques and equipment such as bulldozers (**Table 11** and the wildfire “Hauling chart” in **Figure 24** and Appendix D).

Very few organizations express concern about TFS assets other than the ones they own and/or operate, even when their commodity supplier is shown to be exposed to wildfire and/or flooding according to our modeled results or historical events (See Appendix E.2.1). This lack of concern contrasts with stakeholders frequently mentioning product pipeline assets as an essential part in the system because of their lack of redundancy and their critical role in fuel distribution in the state. Deeper investigation is specifically conducted with Kinder Morgan, Inc. to better understand their exposure to flooding and wildfire (see section 4.6).

In terms of areas of concern, stakeholders repeatedly note the major TFS hubs in the Los Angeles/Long Beach port complex and in the San Francisco Bay Area covering assets from Brisbane to Oakland, through Richmond, Martinez, and Benicia, extending all the way to Stockton. These areas are identified as such because of their high concentration of major assets (TFS hubs) and proximity to sea level. These hubs are highlighted as obligatory points of commodity transit for supply and distribution, which is why they are critical. Other vulnerable areas mentioned include San Diego, Sacramento, Riverside, Temecula, and Colton. We find that expressed areas-of-concern are localized – organizations in Southern California are concerned about Southern California hubs while Northern California organizations are concerned for Northern California hubs – unless their organization has assets spanning the state.

The location of specific areas of concern identified during the stakeholder engagement activities are shown in **Figure 33** and summarized in **Table 12**, along with specific assets of concern within those regions.

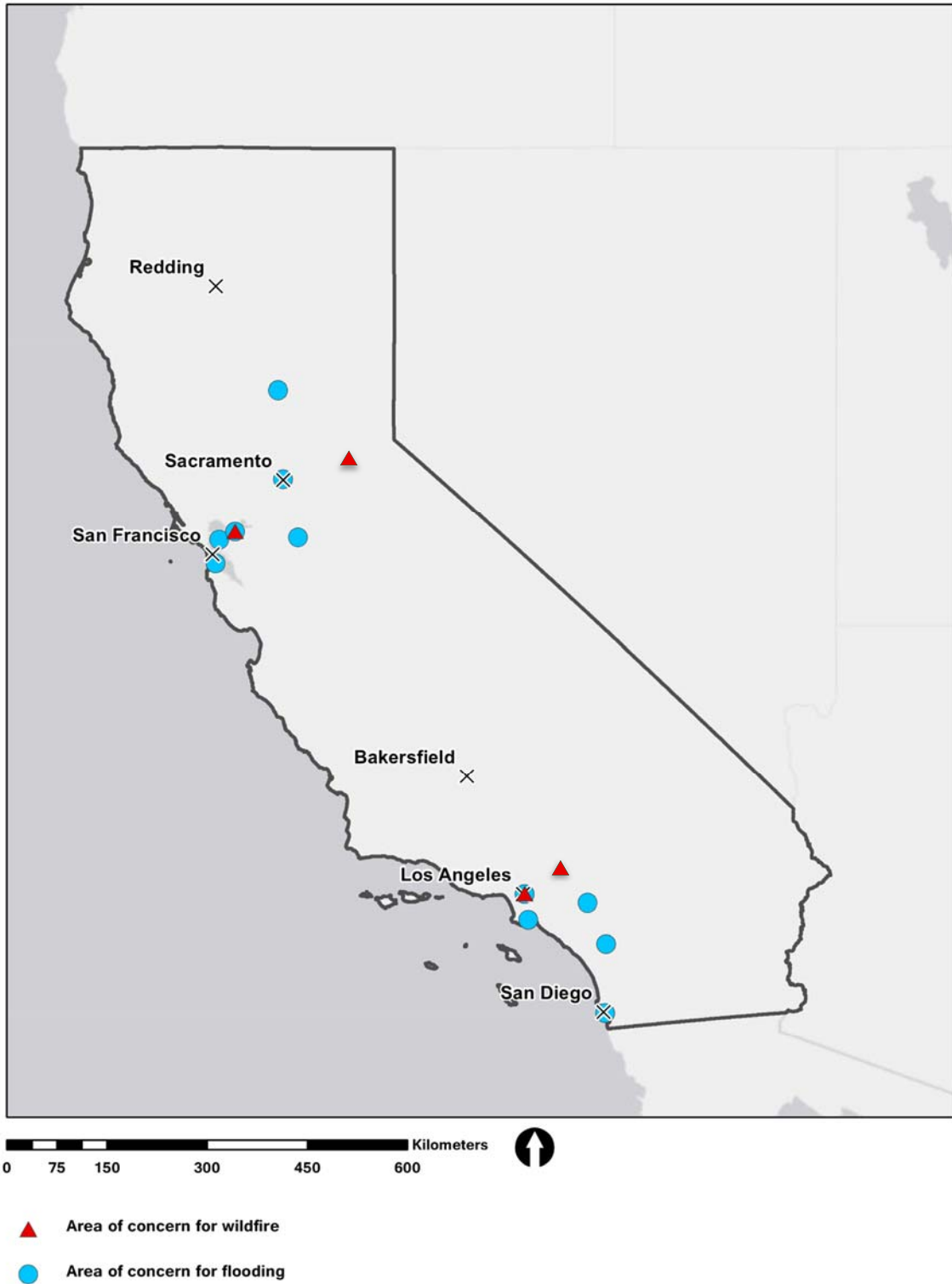

Figure 33. Areas of concern mentioned during the TFS stakeholder discussions

Table 12. Summary of areas and assets of concern

Key TFS Infrastructure	Areas of Concern	Assets of Concern
Pipelines	West of Sierras Foothills (Northern CA) San Gabriel Mountains (Southern CA)	Aboveground appurtenances, pumping and valve stations, and power as an interconnected dependent infrastructure.
Waterways and associated infrastructure	San Francisco Bay and Los Angeles/Long Beach TFS hub areas	Storage tanks, dock fenders, and product pipelines.
Railways	Feather River Canyon	Signal infrastructures and rail transect with wooden ties.
Refineries	San Francisco Bay and Los Angeles/Long Beach TFS hub areas	Pumping stations, vital inputs and other interconnected critical infrastructure (power and water), and product pipelines.
Road and trucking companies	West of Sierras Foothills (Northern CA) and Cajon Pass (between San Gabriel and San Bernardino Mountains in Southern CA,)	Distribution terminals transloading fuel to trucks and product pipelines.

4.3 Adaptation Interests and Efforts

The following section covers existing strategic interests of TFS stakeholders in terms of responding and adapting to extreme weather-related events in general, followed by some focused information on flooding and wildfire hazard mitigation and adaptation strategies. We do not intend to cover the extensive literature on climate change adaptation strategies. Moreover, we do not explore the division between strategic actions that cover emergency preparedness for near-term abrupt events and strategic actions that address long-term chronic threats. Our goal is to outline what our discussions with stakeholders reveal as strategies being employed or considered in light of current and expected extreme weather events, particularly flooding and wildfire.

Two types of adaptation responses to climate change recur in the transportation energy sector literature: those focused on physical or infrastructural response, also referred to as hardening actions, and those focused on behavioral or structural responses (policy frameworks), also referred to as resiliency actions (Acclimatise, 2009; Ebinger & Vergara, 2011; IPIECA, 2013; Neumann & Price, 2009; U.S. Department of Energy, 2010).

Our findings on adaptive efforts are likewise subdivided into hardening measures and resiliency measures. Following the definitions proposed by the U.S. Department of Energy (2010), we interpret hardening measures as those intended to improve the durability and stability of the infrastructure’s physical aspects, thereby improving its capacity to sustain damage. In contrast, resiliency actions as defined do not directly prevent damage, but enable the continuous supply and distribution of a commodity (fuels) despite any damage or disruption, as well as promote a faster recovery to normal operations.

The next two subsections present a summary of our findings regarding TFS stakeholders hardening measures and resiliency activities.

4.3.1 Currently Implemented or Under Implementation

Stakeholders indicate a number of hardening and resiliency measures currently being implemented by organizations to protect assets. These are described below, but it is important to note that many identified measures and actions are multi-hazard approaches and are not exclusively implemented to face extreme and chronic weather challenges. Stakeholders do identify a few hardening measures for flooding specifically and behavioral changes in vegetation management around TFS links and node assets to reduce exposure to wildfires.

It is also relevant to note that many retrofitting and design adaptive measures that are mentioned by stakeholders are driven by hazardous material regulations. This is significant because owners and operators of TFS infrastructure consider these regulations as opening or closing windows of opportunity to implement infrastructural adaptation measures. Such regulations include building code programs such as the Marine Oil Terminal Engineering Maintenance Standards (MOTEMS) regulated by the California State Lands Commission and regulation AB 864 (Oil spill response: environmentally and ecologically sensitive areas). An example on the federal level is PHMSA's pipeline integrity management in high consequence areas regulation (49 Code of Federal Regulations 195.452). Still, these windows of opportunities for implementing adaptation measures predominantly focus on environmental vulnerability in relation to spills and not necessarily the vulnerability of the TFS as critical interconnected infrastructures.

4.3.1.1 Hardening Measures

Hardening measures are mostly focused on improving the robustness of installations to withstand hazardous weather conditions that are not all necessarily due to flooding or wildfire. Some measures that stakeholders mention include construction of classic defensive structures such as flood walls (for coastal and inland flooding) and placement of infrastructure in elevated zones, such as berms and dikes. Assets such as pumping and valve stations, which are mentioned to be critical for the operations of pipelines, are placed on higher ground.

Other hardening measures are related to design and materials. For example, wood materials may be upgraded to concrete or steel, or concrete pipelines may be replaced or modified with flexible membrane liners. Assets may be secured with anchorage systems, such as those used on fuel tanks to prevent buoyancy. They might also reinforce the asset's robustness through design by duplicating pipeline membranes, as another example.

These design strategies overlap with defensive and protective measures but differ when they are applied more holistically to infrastructure. Many of these design strategies are attached to building code programs such as MOTEMS. Others are guided by programs of environmental certification such as the Leadership in Energy and Environmental Design (LEED). In these cases, the existing assets and facilities are replaced by alternatives that incorporate broader sustainable operational practices that go beyond preoccupation with weather hazards and include measures that will lower cost, allow for rapid installation and reduce maintenance.

Another hardening measure is technological design implementation, as exemplified by the modernization of semi-manual fuel flow operational systems to fully automated industrial

control systems such as Supervisory Control and Data Acquisition (SCADA) or similar control systems.

4.3.1.2 Resiliency Measures

Most of the resiliency actions stakeholders mention relate to behavioral responses undertaken at the organizational level. Participation in mutual aid or logistics preparedness groups that work together for emergency preparedness are examples of a resiliency action. This involves interaction between private actors in the same industry (working groups), as well as between private and governmental actors, including the Defense Logistics Agency and the Energy Commission. In this same line of resiliency measures, there are also anticipatory behavioral activities. These include conducting table-top exercises for emergency situations; having emergency management plans for fuel shortages (Fuel Emergency Plans) or for other weather-related external threats; and hiring consultant services or participating in research grants to identify assets that are in risk-prone areas through production of hazard and risk maps.

Many stakeholders mention specific behavioral actions that relate to adapting their operations and procedures. An example is having fuel trucks replacing retail fuel service closer to fuel demand points during emergency response situations. Using trucks for on-site storage is cost- and time-efficient, but it requires portable adaptable hoses and nozzles that are not common for commercial fuel tank trucks. Other specific actions currently employed include preventively shutting down fuel flow between TFS nodes in the event of threatening weather conditions or keeping fuel tanks full to avoid buoyancy in case there is flooding. For wildfire risk, the most commonly mentioned behavioral mitigation strategy is vegetation treatment or maintenance of defensible space around the infrastructure or in right of ways.

Our discussions suggest that another very important resiliency strategy for stakeholders is the insertion of redundancy of flow paths for fuel—either by multiplying the paths of the same transportation mode (e.g. multiple rail routes) or by different modes (rail and pipeline). Stakeholders also see redundancy as important for the functioning of critical equipment, not least of which are pumping and valve stations. Many of the stakeholders we engaged with worry about power failure and some opt for alternate sources of power supply such as cogeneration options that generate power along with the stakeholder’s main operations.

Finally, repeated impact from extreme weather events may lead to the relocation of a TFS asset to a lower-risk area. However, this resiliency option has high costs and is only mentioned as an alternative for certain TFS links, primarily roads and occasionally railways.

4.3.2 Implementation Interest

We ask stakeholders whether they are interested in implementing hardening or resiliency measures to protect their assets from exposure to extreme weather-related events. Some reported interest in the development or increasing of protective (hardening) measures, such as floodwalls and reinforcing pipelines. Interest is expressed in the resiliency actions of increasing the redundancy of transportation modes for supply or distribution, as well as in the possibility of changing the flow direction in pipelines and being able to rely on redundant demand and supply points.

Stakeholders suggest that awareness of exposure to extreme weather-induced events can be promoted through working groups and meetings. Stakeholders propose the identification of high hazard areas that overlap with their assets and the development of impact scenarios with

cost assessments. They also comment on creating defensible space for wildfires and promoting more rigorous mitigation actions on parcels and right of ways. Last but not least, stakeholders mention interest in the facilitation of waivers for fuel commodity transactions, even though this is mostly considered a reaction to supply chain disturbance as opposed to a proactive behavioral change for adaptation.

4.4 Converging Exposure Projections and Planning Time Horizons

Most stakeholders do not exceed 10 years for their current planning and investment cycles, with 20 years as the limit for their strategic planning. These time horizons are not aligned with the much longer-term extreme weather exposure found in existing climate change research. Therefore, to better relate to the outer limits of our stakeholders' planning horizons, this project's exposure projections follow five 20-year periods from 2000 to 2100. This allows for near- and long-term exposure assessments. Stakeholders also express a concurrent need for high probabilistic modeling results in order for potential measures to fit their key decision-making processes, including those for risk assessment and management.

Stakeholders suggest that research studies should look at the life-cycle of the TFS assets and to relate those to projections of exposure. Some stakeholders give rough estimates of the life-cycle length of their infrastructure assets, but with some inconsistencies. A 50 to 75-year life-cycle for pipelines is considered reasonable by some, while others suggest their assets' life-cycle is indefinite as long as the infrastructure is properly managed. However, the actual life-cycles of the assets depend on a variety of factors, such as the environmental exposures (soil acidity and median weather conditions), pipeline integrity management plans, quality of maintenance, etc.

It is important to note that the window of opportunity for hardening TFS links (such as pipelines, roadways, and railways) is more complicated than nodes given that these links are subject to "quick fixes" and a complete replacement of a pipeline, for example, would rarely be applied. Some stakeholders also question the very relevance of petroleum-based products in transportation energy in the future with alternative transportation energies such as hydrogen and electricity increasing in popularity. These challenges further amplify the difficulty of implementing long-term adaptive strategies, where the uncertainty intrinsic to long-term planning has a clear dissuasive effect on the TFS core organizations. However, it is beyond the scope of this study to further investigate reasons for the aversion to long-term thinking and uncertainty, which has been associated with climate change inaction at the individual, organizational, and institutional levels through psychology, sociology, and organizational theory (Slawinski, Pinkse, Busch, & Banerjee, 2017).

That said, it is also important to underscore that TFS assets have long been and are still subject to flooding and wildfire risks, suggesting a no-regrets approach to undertaking adaptive measures into the foreseeable future. As such, we expect there to be increasing demand by TFS stakeholders for increased high-resolution flood and wildfire modeling applicable to already at-risk assets now and into the next decade and more.

4.5 Concerns about Climate Model Resolutions and Effective Stakeholder Engagement

Throughout the stakeholder engagement process, stakeholders express difficulty in utilizing the proliferating climate-related projection models. Different governmental organizations propose a

variety of hazard modeling approaches, which challenge stakeholders in their attempt to narrow down the scientific information for their risk assessment, management, strategic planning, and investment purposes.

Downscaling each exposure potential to the asset level at finer resolutions is one way to address the uncertainty surrounding the use of larger scale climate hazard modeling. The downscaled models are more aligned with the stakeholders' risk assessment, which involves understanding how climate projections lead to exposures that are altered in severity and frequency and how an asset's propensity to damage is changed.

In addition, we find that smaller group interactions with stakeholders lead to greater information exchange and discussions compared to large-group engagement approaches, such as workshops and meetings. The smaller group set-up allows for more in-depth discussions of how specific exposure projections that lead to altered severity and frequencies of events that threaten specific assets.

4.6 Engagement with Kinder Morgan, Inc.

Given Kinder Morgan, Inc.'s (KM) role as the sole common carrier of petroleum products in the state and thus their centrality to TFS operations, we held discussions with KM to better understand their infrastructure and operations affected by extreme weather exposure associated with flooding and wildfires. In addition to our broader stakeholder engagement process, we work with KM staff (located in California and Houston) to focus targeted flood and wildfire exposure modeling on KM assets that they identified within the state.

In discussion with KM, we focus on flooding exposure in the Northern California area of the Brisbane-Richmond-Concord-Martinez complex and wildfire exposure in the Richmond-Sierras-Reno complex, heading south along the major KM pipelines. In addition to holding discussions with Northern California KM staff and working with information management staff in KM's Houston office, we meet with key management staff (scheduling and operations management) in KM's Orange Control Center (OCC) at their terminal in Orange, CA.

Based on our KM discussions, we conclude that:

- More frequent and intense flooding and wildfires have a triple impact on KM operations in the state: 1) KM assets could be directly flooded or disrupted by wildfires, 2) key interconnected infrastructures that KM direct operations depend upon, including but not limited to electricity, could themselves be flooded or subject to disruption by wildfires or flooding taking place in other areas, and 3) the effect of increased and intense wildfires and flooding, wherever they occur in the state, will substantially increase pressure on the State's emergency management infrastructure (and its federal counterpart within the state), which in turn depend on KM supplies and which KM depends upon for protection and mitigation during flooding and wildfire emergencies.
- However, KM already has experience with flooding (washouts) and wildfire events in its Pacific Region, such that new flooding or new wildfires, even when induced by climate change, are not novel phenomena to their real-time operations. It is our observation that the OCC has real-time procedures for its controllers to follow for flooding and wildfire events affecting KM assets monitored in real time.

- From our TFS perspective, it would be misleading to talk about a self-contained “Kinder Morgan, Inc. system” in California when it comes to real-time operational purposes important for flooding and wildfire events:
 - For the OCC’s real-time scheduling, there are five “hubs” to KM Pacific Operations (Portland, Richmond, Concord, Watson, and El Paso), each with its own stations/ terminals and set of pipelines, each pipeline of which has its own set of special characteristics for real time scheduling purposes.
 - For the OCC’s real-time operations, KM Pacific Operations are spread across different control room consoles, each console responsible for a different set of pipelines going from or into the terminals and stations, not all of which are in California.
 - With respect to flooding and wildfires it is best, we conclude from our observations and discussions, to treat each of the major KM pipelines, if not the terminals and stations, as individual systems.
- From our TFS perspective, wildfire and flooding scenarios must be distinguished from each other, irrespective of the pipeline or station/ terminal asset involved. Transmission flows can and have been disrupted by major washout events due to rainfall; underground flows, however, are reported to continue during a wildfire event.
- Power (principally electricity) is a fundamental part of the real-time KM pipeline flow operations. In the state, they chiefly rely on Pacific Gas and Electric Company (PG&E) and Southern California Edison for electrical power. Without electricity, KM would not have working pumps, and thus may be unable to sustain flows. Moreover, real-time operations are central to informed risk assessment and management when it comes to flooding and wildfire events. The importance of highly reliable energy to KM assets is evidenced in major ways, including:
 - KM needs electricity to monitor key real-time operational variables in real-time for its OCC controllers. These variables include: flow rate, line pressure, and viscosity of the different products (diesel, gasoline, and jet fuels), all of which require electronic measurement.
 - In particular, KM depends on electricity for pumping purposes. Its power sources could be disrupted by future flooding and wildfire events, even when these specific events do not take place at or adjacent to KM assets directly.

In other words, while the energy sector is interconnected with the TFS, particularly when it comes to cross-sectorial strategic planning purposes, energy (and the same holds for water and refineries) is so critical and integral in real time that the TFS assets themselves would not function reliably without the energy sector’s inputs.

5: Conclusions and Future Directions

This chapter presents the overarching conclusions of our research, discusses the implications of those conclusions, sets forth our suggestions for future research, and highlights the value of our methods. We present specific conclusions related to our development of an extensive conceptual model of the TFS; our statewide and fine-resolution modeling of TFS exposure to extreme weather-related flooding and wildfire over time and across future climate scenarios; and our stakeholder engagement. We discuss the implications of these conclusions for the sector and for policy as well as our suggestions for future research. Finally, we emphasize the value of our methods.

5.1 Conclusions

In general, we find that stakeholder interaction is critical. Input from stakeholders helped determine the necessity and added value of high(er) resolution modeling, helped indicate the necessity to also look at exposure of key interconnected infrastructure that the TFS depends on, and helped determine that, while our flood and wildfire modeling efforts describe exposure of TFS assets, they do not describe the degree of impact associated with that exposure.

To determine the actual vulnerability of TFS assets to exposure of flooding and wildfire, additional stakeholder interaction is needed. For example, many pipelines are buried, and even though water may inundate the surface above, it might not impact them. However, stakeholders indicated that associated surface control facilities might be highly exposed and thus vulnerable to exposure. Currently there is little data about such facilities and close interaction with relevant stakeholders is needed to model exposure to the facilities. Most of our wildfire risk discussions with TFS stakeholders centered around pipelines, railways, and roadways, as these are the assets in the State most exposed to wildfire. From stakeholder discussions, we learn that grass fires do not burn with great enough heat intensity to damage an underground pipeline or aboveground roadways; however, they may threaten more vulnerable elements of railway infrastructure.

5.1.1 TFS Conceptual Model

We develop a conceptual organizational schematic of the TFS in order to identify the assets that are necessary for the reliable supply and distribution of transportation fuels in California. We explain the key assets as nodes and links, describe their multimodal connections, and identify their various dependencies on each other. We also use the conceptual model to identify TFS stakeholder organizations and examine the relationships and institutional frameworks that shape the behavior of these organizations.

Characterization of the TFS as a Network

Our development of a TFS conceptual model advances the understanding of the connectedness and complexity of California's TFS. There is no formal definition of what constitutes a TFS, much less what the TFS represents at the California state level. The conceptual model we developed contributes to our understanding of the TFS in ways that are not described in the existing literature. It also enables identification of a variety of stakeholders across the sector to engage, many of whom, to our knowledge, have not been previously included in stakeholder outreach.

While our conceptual model connects many TFS infrastructure assets together, no one organization alone manages the movement of crude oil in the state from supply, to refining, to the end-user as a product over this highly networked system. Our stakeholder discussions regarding the conceptual model demonstrate that the “TFS” itself consists of multiple sub-sectors that could each be represented by their own conceptual model, yet product flows are dependent on their intraconnection as a network. Contracts and agreements between members of the TFS effectively move crude oil and fuels through this network. Accordingly, most asset managers understand only the system directly up and downstream from their asset; few have a complete understanding of the entire TFS. With private companies making up the TFS, and their proprietary-market constraints, no one stakeholder can be expected to have complete knowledge of the entire sector. Nonetheless, product flows downstream toward final consumption are highly dependent on its vertical integrity.

While not included in our conceptual model of the TFS, TFS stakeholders underscore the importance of interconnected external industry infrastructures that are critical to the TFS’s successful operation. The TFS is not a stand-alone industry and is interconnected with many other key external industries (e.g. electrical, gas, and water) necessary for its successful operations.

Characterization of Operational Connections Within the TFS

There is competition but also cooperation within the TFS and through discussions with TFS stakeholders, we are able to identify where these conditions lead to redundancy in the system and where the TFS is at risk of failure due to lack of redundancy (G. Schremp, personal communication, December 28, 2017; J. Settles, personal communication, February 8, 2018). Competition ensures redundancy in the network and cooperation has served the TFS well during emergencies. For example, gas station operators have options in suppliers. If one company goes offline for an extended period of time, another competitor will often take its place. Companies can also cooperate and purchase product from each other to fulfill a contractual obligation if their ability to deliver is thwarted by an asset being offline. However, we discover that there are critical assets where little or no redundancy exists. Here, the fixed costs of construction can limit competition and the specialized nature of the asset facilitates cooperation among TFS stakeholders. Both cooperation and competition can lead to situations where the TFS is resilient or to circumstances where the TFS is vulnerable in the absence of resilience. Those assets that lack redundancy can be considered critical assets in the TFS.

Refined Product Pipelines Are Critical Assets in the TFS

Our characterization of the TFS reveals that refined product pipelines are the most critical asset and the greatest threat to breaking the flow of fuel within the TFS network. Many of these pipeline assets are the singular link between refineries and intermediate transshipment nodes or end node terminals, with no redundancy in place. If these pipelines go out of service for an extended period of time, the TFS could suffer a debilitating failure. Refined fuel would need to be transported by road and/or rail and the number of vehicles required for this task could easily outnumber those available to the TFS. Although in some specific circumstances marine transportation might serve to reduce the impact of pipeline failure, it is highly likely the loss of key product pipelines would cripple the TFS (G. Schremp, personal communication, December 28, 2017; J. Settles, personal communication, February 8, 2018).

Central Distribution Terminals Are Critical Assets in the TFS

Central distribution terminals are critical assets to the operational success of the TFS as many refineries transport fuels to such terminals via pipeline for further distribution. The two highest product throughput volumes in the TFS (post-refinery) occur at the Concord terminal in northern California and the Watson terminal in southern California. Kinder Morgan, Inc. operates both and they are considered central distribution terminals. They represent fuel convergent nodes, one step before distribution. Here, cooperation exists between various companies and refined fuels from different refineries are mixed and further transported throughout the TFS. If one refinery goes offline for a period of time, fuels from other refineries can serve to make up the shortage and redundancy is achieved. However, if these individual terminals fail, the inability to move fuel in the system could seriously disrupt the TFS.

5.1.2 Flood and Fire Exposure under Climate Change

We model flooding and wildfire hazards over time under a range of future climate change scenarios to analyze where TFS assets are exposed to these conditions. We model these hazards statewide at a coarse resolution of 50m (~164ft) for flooding and 6.2km (3.9 miles) for fire and evaluate the exposure of existing TFS assets. After presenting the short- and long-term results to stakeholders in various meetings, their interest and expertise guided us to locations in the state where they wished to see their assets modeled at finer spatial resolutions. In these selected locations, we model flooding and fire hazards at a fine resolution of 5m (~16.4ft). Overarching conclusions from these modeling efforts are described below.

5.1.2.1 Statewide Modeling

Our statewide hazard modeling and exposure analysis reveals broad patterns of TFS asset exposure that vary by hazard, asset type, and region. In terms of flooding at this scale, we introduce a strategy of modeling coastal flooding over a range of SLR and storm surge projections and time horizons. Using the Fourth Assessment data (Cayan et al, 2016), we model coastal flooding under 24 sea level scenarios projected with two greenhouse gas concentration scenarios (RCPs), four climate model (GCMs), and three probabilistic SLR (50th, 95th, 99.9th percentiles) values for 50m (~164ft) spatial resolution tiles along the entire California Coast, San Francisco Bay, and the Sacramento - San Joaquin Delta. We base our statewide wildfire assessment on Westerling's (forthcoming) projections. We take estimates of area burned from all 240 scenarios modeled by Westerling (forthcoming) into account when evaluating regional and sub-regional changes in California wildfire patterns over the current century and between specific 20-year long planning horizons. We then spatially intersect these modeled extreme weather event projections with TFS asset data to evaluate the potential for exposure. The results of this modeling are presented in Chapter 3 and Appendices C and D. Important takeaways are described below.

Our Modeling Represents a Breadth of Possible Climate Change Outcomes

We assert the outputs of our modeling represent the range of possible outcomes under the various climate scenarios. We find that using the full range of scenarios in our flooding and wildfire modeling is critical in gaining the attention of stakeholders who might otherwise discount results from a single specific RCP or GCM. In terms of flooding, we ranked 24 coastal flooding events in 20-year intervals by their highest projected sea level to identify the maximum, median, and minimum events to quantify the range of flooding, to the year 2100. The purpose of the scenarios is to reveal spatial patterns of inundation exposure and not to

identify any one particular inundation scenario for subsequent risk analysis. We conclude the maximum and minimum scenarios are most useful for revealing trends and we use median scenarios to describe effects on an individual operator within the TFS. In terms of fire, we develop a modeled wildfire threat ranking based on Westerling's (forthcoming) forecasts across 240 scenarios from two RCPs, four GCMs, and three LULC scenarios (with 10 stochastic variations each). We base our fire hazard classification of individual pixels in various time periods on the relationship of the median modeled pixel value for a given period to that in our 2000-2020 reference period.

Spatial Trends in Modeled Flooding and Wildfire

Coastal flooding across scenarios and through time is mainly found in low lying, flat, and coastal regions along the California coast, in the San Francisco Bay, in the Sacramento-San Joaquin Delta, and in the Long Beach and Huntington Beach regions in Southern California. The Sacramento - San Joaquin Delta is particularly exposed to flooding in the statewide 50m (~164ft) spatial resolution model due to the Delta's low-lying topography, possible overtopping of the levees, and to some extent because of the coarse spatial resolution of the model (i.e. smooth representation of the topography).

Large (>400 ha) wildfire patterns are expected to vary throughout California over the remainder of the current century. Forested sub-regions of the state are expected to experience a marked increase in exposure to large wildfire over this same period of time. Modifications to current modeled wildfire patterns appear to be largely driven by changes in land cover and wildland fuel stocking levels, as well as by projected fluctuations in local climate conditions over time.

Patterns of TFS Asset Exposure to Flooding and Wildfire

Flooding

The collective of all TFS assets (i.e. refineries, terminals, docks, airports, gas stations, oil fields, pipelines, roadways, and railways) are not greatly exposed to projected coastal flooding statewide, as only a small portion of each asset type is found in flood-prone areas. The exposure pattern can be explained by the assets' locations relative to low-lying coastal zones.

For the five 20-year periods analyzed, on average, about 5% of a TFS asset category are exposed to some level of coastal flooding. Gas stations are the least exposed to coastal flooding (1% on average over the five periods), whereas docks are most exposed (12% on average over the five periods).

In general, our 50m (~164ft) spatial resolution flood modeling demonstrates that the exposure characteristics vary by geography (Northern versus Southern California), asset type and ownership (large versus small operators). For example:

1. Most product pipelines in Northern California exposed to coastal flooding are operated by a single large operator with a significant length of pipeline exposure but affecting only a small fraction of its overall pipeline assets, whereas in Southern California exposure is distributed among several operators with some small operators with large percentages of their assets highly exposed.

2. While we consider the crude oil pipeline system as one statewide network, there are significant differences between the SF Bay/Delta and LA/Long Beach regions. In both areas, the largest crude pipeline operators (in terms of total kilometers of pipeline assets) have the longest length of assets exposed. Similar to the exposure of product pipelines, this exposure represents a small percentage of their total assets, while small operators have higher percentages of their assets exposed. Regionally considered, the LA/Long Beach crude oil pipeline asset exposure is six times that of Northern California (60 km exposed at the median flood scenario in the period 2040-2060).
3. In Northern California, terminals tend to be more clustered around the greater Bay Area refineries – many of which are in shoreline locations. Most of these assets are exposed to coastal flooding, but only in the maximum flood scenario in the 2080-2100 period. For example, the terminals at Martinez (with the exception of the Plains Products Terminals), in the Richmond area (except the IMTT terminal), and the KM SFPP Liquid Petroleum terminal facility at Brisbane, are only exposed under the maximum scenario in the 2080-2100 period (See **Figure C 17(a-c)** in Appendix C). Only a few terminals in the Bay Area are exposed in the minimum flood scenario in the 2080-2100 period, such as the IMTT terminal at Richmond. Kinder Morgan, Inc. Station in Concord is not exposed to any projected coastal flooding.

In Southern California, terminals are more widely scattered throughout the LA/Long-Beach area, many of which are away from coastal locations (**Figure C 18**). In this region, 11 terminals are subject to maximum 2100 flooding and 6 exposed to minimum flooding.

4. Refineries in Northern California are predicted to be flooded as early as the 2020-2040 period. Our scenarios indicate a 176-223 ha, (14-18%) inundation of the Chevron refinery at Richmond occurs by 2040 (min, max scenarios) and by 2100, a 240-697 ha, (20-57%) inundation occurs. At the Andeavor Martinez refinery (min, max scenarios) 0.6 – 2 ha (0.4 - 1%) of inundation occurs during the 2020-2040 period and by 2080-2100, the range increases to 4 – 117 ha (2 - 68%). Together, the area inundated at all other SF Bay/Delta refineries is 10 - 22 ha (1 - 2%) by 2040; and 51 - 204 ha (5-17%) by 2100 (See **Table C 8** in Appendix C).

In the LA/Long Beach region, the only identified refinery exposed to flooding is the Valero Wilmington facility located at the end of the Dominguez Channel in the Los Angeles Harbor. This facility's exposure is significant in terms of area: by 2040, 33-47 ha (40-50%) are inundated and by 2100, 65-84 ha (77-100%) (See **Table C 8** in Appendix C).

Wildfire

Increases, decreases, and relatively insignificant changes in wildfire frequency and magnitude are projected to occur within TFS asset-containing regions of the state. TFS assets located in many of California's mountainous sub-regions are expected to experience a marked increase in exposure to large (>400 ha) wildfires between now and the end of the century. Notably, increases in the likelihood of large wildfires are projected to occur in the Siskiyou Mountains and Klamath region of Northwestern California; at mid- to high elevations of the Sierra Nevada; in the Transverse and Peninsular Ranges running between Santa Barbara and Baja, Mexico; and in the multiple Coastal Ranges that fall between Monterey Bay and Los Angeles. In contrast, TFS assets found in low-lying regions of the Central Valley, the Sierra Foothills, the San

Francisco Bay, Los Angeles County, and San Diego are expected to see little to no change in the likelihood of large wildfires over time.

At the state level, TFS road, rail, and airport asset types are expected to see the greatest increases in exposure to the threat of large wildfires over the course of the five 20-year prediction periods analyzed. Statewide exposure of pipeline and gas station assets are expected to increase slightly from current levels (See **Figure D 21** in Appendix D). TFS terminals and refineries face relatively little, if any, threat from large wildfires during present and future periods.

Uncertainty in Hazard Modeling and Asset Exposure Increase Further in the Future

The uncertainties in future coastal flooding and wildfire from different climate scenarios are relatively small at the beginning of the century (i.e. 2000-2020 period) but become much more pronounced by 2100. Thus, similar uncertainty patterns in TFS asset exposure to coastal flooding and wildfire are also observed. Moreover, given the coarse resolution of the statewide flooding and wildfire modeling, the results are primarily appropriate to interpret at the statewide level. Fine resolution modeling is more appropriate for localized asset exposure analysis.

Wildfire is Presently a Major Threat to TFS Assets

Wildfire may be the biggest immediate threat to TFS assets as short-term severity can damage critical infrastructure. Critical TFS assets are located and currently operate in areas at risk of exposure to wildfires, and in some cases, assets have existed in risky areas for years. One type of critical asset, refined fuel pipelines, crosses regions of California that we conclude are at high risk of wildfire-related disruptions. Moreover, when rainstorms follow fire they can produce dangerous flash floods, slope failures, and debris flows that can destroy infrastructure. Although operators of the TFS have an excellent record of response and repair to damaged infrastructure and have a history of effectively returning to operational mode, chronic disturbances due to climate change will only tax this ability. In addition, given the interconnected nature of the TFS with support infrastructure (electricity, gas, and water), wildfire disruption to one of these interconnected assets may also serve to interrupt the TFS.

5.1.2.2 Fine Resolution Modeling

We find that fine resolution modeling of flooding and wildfire allows for more accurate exposure evaluation for specific TFS assets at a local scale and is more effective for engaging stakeholders in discussions of asset vulnerability. For our fine resolution 5m (~16.4ft) simulations, we employ remotely sensed high spatial resolution information to improve low spatial resolution variables and enhance the detail of our flooding and wildfire modeling. We perform this modeling for selected time periods in specific areas with TFS asset concentration, flooding or wildfire exposure, and interest expressed by TFS stakeholders. For fine spatial resolution flooding, we model both coastal and inland flooding at 5m (~16.4ft), with inland flooding based on rainfall intensities during projected extreme rainfall events. In addition, at such a fine spatial resolution, blocking objects, mostly buildings, impact flooding results, so we alter our input surface models to include them. In terms of wildfire, we introduce an improved land cover classification approach, model wildfire behavior at a spatial resolution of 5m (~16.4ft), and derive output metrics including flame length, fire intensity, and rate of spread. We model future wildfire conditions driven by Fourth Assessment LOCA data representing

future extreme conditions of temperature and relative humidity, while we keep all other conditions (topography and vegetation) the same as present.

The results of our fine spatial resolution modeling are presented in Chapter 3 and Appendices C and D. Key findings from this effort are described below.

Fine Resolution Models Engage TFS Stakeholders

At a fine spatial scale, TFS stakeholders clearly recognize specific components of their assets on the ground in relation to modeled flooding or wildfire conditions and can more effectively consider adaptation and strategic planning. Statewide prediction cell sizes (50m (~164 ft) for flooding and 6.2km (3.9 mile) for wildfire) are too coarse for TFS stakeholders to recognize a threat to their infrastructure assets. While it takes considerably more computer power, the value added of our fine spatial resolution flooding and wildfire modeling is quite important for future strategic planning and response in protecting TFS assets. Importantly, we find that stakeholders can recognize assets, other structures, and complex environmental conditions in areas of interest and thus actively engage in our analysis. We expect the demand by TFS stakeholders for fine spatial resolution flooding and wildfire modeling, with its enhanced utility for real-time operations, to increase in the foreseeable future.

Fine Resolution Modeling More Accurately Represents Localized Asset Exposure

In coastal flooding, the fine spatial resolution 5m (~16.4ft) model refines the results of the coarse resolution 50m (~164ft) model, and therefore better informs stakeholders about their flooding exposure in local sites. In addition, our fine spatial resolution flood model is likely a more accurate estimate of flooding exposure as it incorporates inland flooding, better captures changes in topography, and includes blocking objects such as buildings that determine realistic potential water flow pathways. Similarly, within wildfire prone regions, wildfire hazard to assets vary as different topography and vegetation pose different degrees of asset exposure. For example, assets in forested regions are at high risk because trees burn with the highest heat intensity. However, during a wildfire not all trees necessarily burn. Given this, modeling wildfire behavior at a fine resolution with precise landcover classification allows for more accurate evaluation of asset exposure. After experimenting with existing CalFire wildfire threat assessments, we recognize inherent limitations exist in preserving detailed information even at 30m spatial resolution, and this led us to model and calculate present day wildfire hazard potential at a 5m spatial resolution.

Fine Spatial Resolution Modeling Can Be Effective for Evaluating Impact Mitigation Actions

As part of our fine spatial resolution fire modeling, we analyze our fire behavior results using a fire response characteristic chart (the Hauling Chart) to determine potential wildland firefighter engagement techniques and simulate mitigation procedures by modifying fuels to demonstrate the effect on wildfire behavior (Scott & Burgan, 2005). For example, shrubs burn with high heat intensity and are typically quicker to ignite than trees, so one common method to reduce shrubland wildfire risk is mastication, in which a bulldozer grinds shrubland vegetation. We simulate such mitigation measures by modifying the input fuel surface near TFS assets and find that fuel treatments such as mastication can greatly reduce both the rate of spread for the wildfire and the heat intensity emitted by the fire.

5.1.3 Stakeholder Conclusions

As described in Chapter 4, we engage with TFS stakeholders to document their response to our modeling outputs. We discuss their assessment of our modeled exposure of assets to flooding and/or wildfire, as well as their impressions on the potential for consequences from such exposure. In addition, we ask stakeholders to discuss short- and long-term strategic planning they are currently undertaking or would consider undertaking to increase the resiliency of their assets to these hazards. We find this stakeholder interaction critical to obtaining a more complete picture of asset vulnerability and understanding potential adaptation strategies and mitigation measures.

Stakeholder Interaction is Key to Understanding the Vulnerability of Specific Assets

Understanding the concept of “vulnerability” is more complicated than one might suppose and is key to conceptualizing the significance of any exposure. Knowing only that the wildfire and flooding extent intersect with the spatial location of TFS assets (as we define exposure) might not translate directly to damage or an increase in the vulnerability of the asset. Reviewing and discussing the results of our exposure modeling with stakeholders deepens our understanding of the potential for exposure to actually cause impacts to assets and the implications of those impacts.

For example, stakeholder discussions illuminated the susceptibility of TFS railways to damage caused by the direct exposure to heat generated during a wildfire event or water from flooding, specifically when wooden rail ties are present. Rails are damaged at even relatively low levels of exposure to heat. At 40° Fahrenheit, change in temperature can permanently damage a modern rail system (CORT, Personal Communication, Nov 17, 2017). Stakeholders reveal that only 10cm (~4 inches) of flooding is needed to disrupt rail operations. Nevertheless, rails are not the expensive components of a railway and can be repaired or replaced relatively quickly. On the other hand, wildfires and flooding can pose significant risks to unprotected assets and it can be costly to repair traffic signaling infrastructure.

However, some assets may not be impacted even when they occur at the same location as our modeled flooding or wildfire. Underground assets, such as pipelines, are insulated by both pipeline material and soil, and are thereby protected from heat generated by wildfires or from direct impacts of flooding. Yet, TFS pipeline infrastructure is reliant upon aboveground appurtenances that are susceptible to being damaged during a wildfire or flooding event, specifically pumps and valve vaults.

On the other hand, indirect effects associated with flooding or wildfire also have the potential to impact TFS assets. Stakeholders mention that TFS roadway assets can be temporarily disabled by wildfire smoke reducing driver visibility enough to cause road closures. Similarly, refineries and terminals and their associated equipment generally are not directly exposed to wildfire because they are near water and in urban areas. However, indirect wildfire impacts may occur to these assets, mostly as a result of workforce service disruption due to smoke-related air quality impacts or worker absence associated with personal impacts from the wildfire. Wildfire suppression activity can also pose an indirect threat to some TFS assets. Heavy equipment used during wildfire suppression and management, such as bulldozers, is consistently described by stakeholders as a major threat to underground pipelines due to excavation strikes. While we model potential direct exposure to flooding and wildfire, our modeling does not account for potential indirect impacts associated with these extreme weather-related events.

In some cases, stakeholders also highlight the general cost to their company's resources of coping with impacts to assets. For instance, despite redundancy in the California road network, TFS trucking companies are concerned with additional costs due to increased distances and time associated with rerouting. Additional service costs are also associated with delays in access to fewer fuel terminals which reduces overall supply capacity.

Certain Hazard Model Output Metrics are Most Significant to Stakeholders

Wildfire and flood model outputs vary in their significance to stakeholders in assessing the vulnerability of their assets. During TFS stakeholder discussions, the different hazard model output metrics - flood extent, flood depth, and fire intensity - are most commonly referenced by stakeholders when assessing the vulnerability of their assets. The extent of flooding and wildfire exposures is intuitively the most relevant result. We find that fire intensity metrics are less applicable when referred to in raw BTU units. Instead, stakeholders are more responsive when fire intensity results are translated to firefighting suppression viability, such as describing how firefighters will generally attempt to put out fires when intensity is less than 1000 BTU/sq. ft, but their protocol is to retreat when fire intensity is close to or greater than 1000 BTU/sq. ft.

Occurrence of Extreme Weather Events Stimulate Stakeholder Engagement

Extreme wildfire events and subsequent debris flows in the fall of 2017 stimulated TFS stakeholder engagement with respect to wildfires. Wet El Niño years followed by very wet La Niña years, as in 2016 and 2017, lead to the rapid growth of fuels in the wildland regions of California. The added vegetation growth and periods of dry conditions increase the fuel base and amplifies the risk of increased fire intensity. The severe 2017 fires in both Northern and Southern California stripped the landscape of hillslope stabilizing vegetation and led to hazardous post-fire debris flow conditions. The rainstorms in the fall of 2017 produced dangerous flash floods, slope failures, and debris flows that destroyed buildings as well as infrastructure. These occurrences were widely reported in print and television. This public awareness served to enhance our TFS stakeholder engagement with respect to wildfires.

Stakeholders Are Most Interested in Near-term Periods That Match Investment Cycles

TFS stakeholders are focused on the immediate future and they consistently request higher resolution modeling of the 2020-2040 period, consistent with their near-term investment and asset life-cycles and in recognition of the fact that some of their critical assets are already located in present-day flood and fire risk areas. The time horizons for long-term strategic planning for extreme weather hazards do not correspond to the industries' investment cycles and many stakeholders doubt the competitive capacity of petroleum sourced energy in the transportation fuel market in the mid- to distant- future. After modeling the period 2020-2040 at 5m (~16.4ft) spatial resolution for directed locations in California, we then include results from the period 2080-2100 to show longer-term effects and re-engage with stakeholders. Despite this, we find stakeholders do not immediately respond to modeled scenarios that go beyond the next 10 to 20 years. Better risk management cycles may be needed, but even here nearer term risks over their current planning, investment, and depreciation cycles would be the priority concern.

Stakeholder Discussions and Specific Exposure Analysis Are Key to Obtaining Input

The stakeholder engagement process is key to gathering information on the complexities of the TFS network and for the diffusion of modeling results to interested parties. TAC meetings and workshops are not good venues for gathering significant input from stakeholders possibly due

to market competition and proprietary restrictions within the industry. However, they are suitable for information dissemination about this research and its results. Discussions with individual stakeholder organizations are more productive when examining modeling results specific to key TFS organizations. Even then, an NDA may be required and highly useful. This allows the customization of modeling results to an individual organization's unique requirements, especially in terms of delivering high-resolution models tailored to their assets and obtaining inputs of their existing information management systems, operational graphics, and emergency management data requirements.

Organization-specific exposure analysis, coupled with the high-resolution modeling techniques, allows the incorporation of mitigation and adaptation measures that are already in place (flood walls, levees, fire breaks, fuel treatment, etc.) but are usually less visible when dealing with coarse 30m resolution hazard models and satellite imagery. Our high-resolution modeling approach opens the door for stakeholders to tweak their mitigation measures and check how effectively their response reduces their vulnerability.

Stakeholders Show Interest in Strategic Planning for Flooding and Wildfire

Members of the TFS have traditionally been concerned with and focused on their contributions to emissions of criteria pollutants and toxic air contaminants. Now that clean fuels and efficient vehicles have driven emissions of volatile organic compounds far below their historical baselines and other emissions sources provide more cost-effective opportunities to mitigate ozone and toxic chemicals in many air basins (B. C. McDonald et al., 2018), we find through our workshops and discussions that several members of the TFS are adding to their focus adaptation of infrastructure threatened by climate change.

We find stakeholders are, to varying extents, concerned and interested in strategic planning for flooding and wildfire. The most common strategic measures proposed are directly linked to infrastructure hardening such as floodwalls, increasing structural material quality, and the elevation of critical assets. Other stakeholders with assets near sea level also expressed interest in investment for hardening measures such as reinforcing pipelines, as well as developing specific impact scenarios with cost assessments. As discussed in Sections 4.3.1 and 4.3.2, stakeholders propose resiliency related measures, considered "soft" adaptation measures, such as reinforcing action plans, promoting awareness through working groups and meetings, creating defensible space, and the facilitation of waivers for fuel commodity transactions. Most of the proposed resiliency measures fit a pattern of proactive behavior change that can be linked to emergency response. In some instances, stakeholders argue that they have already implemented hardening or resiliency measures, but they still are interested in accessing new model scenarios and their implications.

From our discussions, it is not possible to assess what are the overarching drivers for currently in-place adaptation measures, nor gauge interest in future implementation of adaptation measures. Current actions understandably take a no-regrets approach where possible, meaning there are multiple reasons to undertake them now or in the near future. Common business preoccupations such as rate of return and correlated operational and managerial upgrades, regulations, and past incidents correlated with natural hazards, are all mentioned as reasons for hardening infrastructure or implementing resiliency measures that can decrease vulnerability to flooding and wildfires among other threats. Nevertheless, it is clear that regulation working towards the implementation of such measures is framed under hazardous material spillage

concerns and not necessarily from the concern of reliably supplying and distributing fuel (critical infrastructure).

5.1.3.1 Conclusions from Engagement with Kinder Morgan, Inc.

Since KM operates the majority of the product pipelines and refined fuel transmission in California, there is little or no redundancy of this class of pipeline asset among the various stakeholders. As a result, we conducted numerous interviews with KM to further examine critical TFS product pipeline exposure. Our engagement focused on flooding exposure in the Northern California area of the Brisbane-Richmond-Concord-Martinez complex and wildfire exposure in Richmond moving southward along the major KM pipelines. The overarching conclusions from our discussions with KM generally mirror and support those of our discussions with other stakeholders.

Regarding wildfires, our interaction with KM revealed that while fires can be a threat to TFS assets – not least of which are equipment plant fires or other mechanical-related fires – a fire taking place at an asset location does not inevitably indicate the asset is vulnerable. The unit of analysis for our research is wildfires, which typically take place outside the perimeter of TFS assets such as refineries or terminals. It is primarily pipelines and pipeline support infrastructure, such as pumps and valves located along the pipeline path, which are located in regions of the state at risk of wildfire. During wildfires, firefighting equipment (e.g., large bulldozers) can damage pipeline assets if equipment operators are unaware of buried pipeline locations and, for example, dig them up while constructing a fireline. Yet, a wildfire taking place at the asset location does not mean it poses a threat to the asset in question. Most notably KM informed us that their flows are by and large maintained when wildfires occur above or adjacent to their underground pipelines. KM pipelines have not sustained notable damage from a wildfire in Northern California and, to our knowledge, KM has not had to shut down or disrupt service indefinitely as the result of wildfires in the State.

Our discussions with KM regarding flooding highlight that inundation can also pose a risk to pipeline system operation. Our coastal flood modeling shows that approximately 6% of the total SFPP pipeline system operated by KM in Northern California is potentially inundated by coastal flooding in the 2040-2060 period (under a median scenario). This low percentage could imply that the system may still be functional in the face of coastal flooding if there are possibilities to reroute product using non-exposed pipelines. However, our interviews with KM representatives, among other TFS stakeholders, identified cases of past inundation and flooding that did pose risks to the operations of individual pipeline systems. In short, no one should conclude that a small percentage of inundated pipeline is not a cause for concern.

One other primary takeaway from our discussions with KM was that long-term strategic planning to the year 2100 for the State's entire transmission pipeline network is unrealistic at this time as the TFS will likely have changed dramatically by then. However, climate-related impacts for the 2020-2040 period could help inform near-term planning.

5.2 Discussion

Our research shows the TFS is extremely complex, both physically and organizationally. The sector functions because of contracts and agreements between all stakeholders. Because of this complexity, no one stakeholder or group that has a comprehensive overview of all of TFS in California or has ability to respond reliably to all exposure risks and uncertainties. This

complexity is also amplified by the fact that the TFS depends on interconnected infrastructure to reliably operate and manage transportation fuel supply and distribution.

According to our modeling, some existing TFS assets are currently exposed to flooding or wildfire. For assets in certain locations, exposure will occur or increase in the future under climate change. However, the TFS stakeholders we engaged with pointed out that modeling of exposure does not give full or detailed information about the actual impact of the exposure to the asset. The impact of flooding or wildfire exposure depends on the asset's physical characteristics such as the asset type and condition. The impact of exposure on the asset also depends on how the asset fits into a larger organizational structure and the institutional framework in the area of the asset to respond to or prevent exposure from leading to long-term negative disruption or damage.

Change over time makes identifying vulnerability and subsequent planning more complex. As the various GCMs and RCPs suggest, climate and weather are projected to change over time; projections suggest that extreme events such as flooding and wildfires will become more frequent, perhaps chronic, rather than occasional. Also, events such as flooding and wildfire may occur simultaneously in different parts of California.

To add to this complexity, the age and remaining operational life of an asset changes with time as will the organizational network in which assets function. New companies emerge, some companies will merge, and assets may be abandoned, sold, or replaced. At the institutional level, complexity is added as markets change, supply and demand change, policies and regulations change, and incentives and funding change.

The uncertainty of what the future holds suggests that, in terms of developing resiliency to future exposure, there should be more coordination within the TFS and with interconnected sectors. According to stakeholders, some coordination already exists, as a result of policy or existing vulnerability of assets, but increased coordination is needed. Adaptation strategies should take into account the present location of assets and subsequent exposure; physical hardening and resilience measures that are possible and feasible and those that are already planned for or required; and funding and incentive strategies available to the stakeholders.

In addition, while this research does not examine directly the effect of flooding and wildfires in an emergency management situation, it is clear from stakeholder discussions that the effect of increased and intense flooding and wildfires, wherever they occur in California, will substantially increase pressure on emergency management infrastructure, which in turn depends on various TFS assets to move and supply fuel.

In summary of the above, the broader policy implications of this research are:

1. Long term planning requires inclusion of scientific and modeling uncertainties and organizational/institutional uncertainties.
2. Multiple extreme weather events have different impacts on TFS assets due to distribution (or lack thereof) throughout the state.
3. Ability to focus at finer spatial resolution allows for better alignment with existing depreciation, investment, and other planning cycles.

4. TFS stakeholders face a certain future where measures to harden or make more resilient their key assets are unavoidable for many different reasons, including climate change.
5. The TFS needs to be viewed as a system that is part of a greater system.

Given the interdependencies and the fact that the TFS is a system that is part of a greater system, stakeholders have indicated that each asset or location should be taken into consideration when making broader decisions around potential implications to the Transportation Fuel Sector as a whole. Making statewide policy that doesn't take the specifics per location, region, or area into account can have an adverse effect on individual locations and on actions already been taken by municipalities, harbors, regions, etc.

5.2.1 Methodological Implications of the Modeling Approach

Specifically, in relation to our modeling approaches, we find the following:

1. Flooding and Wildfire point to different models for vulnerability and/or risk proper.
Example:
 - a. In the flooding scenarios, it is easier to predict the probability and consequences of flooding, given the site of the asset and the specific scenario in question.
 - b. In the wildfire scenarios, where the site of ignition cannot be predicted, it is easier to talk in terms of exposure, vulnerability, and threat (and less so in terms of site-specific probabilities and consequences).
2. The value added of our 5m spatial resolution wildfire modeling beyond the underlying Westerling (forthcoming) coarse predictions is in the added ability to identify where TFS infrastructure is and where assets may be exposed to extreme wildfire behaviors. In addition, we differentiate wildfires with respect to their flame length, fire intensity, and rate of spread. This has very important implications for future planning and response for TFS elements.
 - a. For example, KM's Orange Control Center has developed real-time procedures to deal with wildfires affecting its pipeline operations. However, it may be that any such procedures—including those at other TFS stakeholders' facilities—could be further developed in light of differentiating wildfire responses in terms of their flame length, fire intensity, rate of spread, and understanding what fire suppression strategies are expected during catastrophic fire weather conditions.
 - b. Our statewide modeling focus, however, has the advantage of showing that some TFS elements (e.g., north and south pipeline assets, some refineries) face unavoidable budget and investment tradeoffs as to where to allocate funds and resources to their additional mitigation efforts with respect to the location, nature, and frequency of wildfires.
3. Flood modeling, although starting in 2000, has the virtue of overlapping in its 2020-2040 period with existing, longer-term cycles for TFS stakeholders. For example, findings may have immediate implications for rethinking current investments and/or planned maintenance versus replacement upgrades.

4. It is clear that the relevance of our modeling results to key TFS stakeholders requires working with them in order to customize model results to their unique requirements, especially in terms of each stakeholder's existing information management system, operational graphics, and emergency management data requirements.

5.3 Suggestions for Future Research

Based on our conclusions and their broader implications, this subsection suggests avenues for future research in flood and wildfire modeling, as well as stakeholder engagement.

5.3.1 Flooding

1. Bridge the gap between flood modeling output metrics and damage to TFS assets. More research is needed incorporating information on how flooding exposure will result in damage. With this in hand, one could identify the impact (e.g. if the asset has to be taken offline) on the TFS infrastructure and this approach will help estimate loss related to damage or disruption, as well as further model the cascading impacts throughout the physical and organizational supply-and-distribution networks.
2. Establish an archive of real-time and fine spatial resolution remote sensing images/aerial photos of existing flooding events which can be used to validate the flooding extent simulated by existing models and identify whether new models are needed. In this study, we calibrate our model against recorded water levels at gauging stations during historical events. While this calibration is to some extent satisfactory, it does not directly calibrate the model against its final projections of flooding extent and depth. The inability to conduct such calibration in a systematic manner is due to a lack of long-term, detailed flooding maps of past events. Near real time and fine resolution images would provide an archive of flooding events that have occurred and are happening, which can be used to better calibrate the flooding models. In addition, researchers can use these flooding maps to build statistical and machine-learning models that predict flooding based on environmental conditions such as topography and precipitation. Compared with the process-based, deterministic flooding models (e.g. the model used in this study), the statistical and machine learning models can easily scale up to large study areas and long-time periods, such as California and an assessment to and beyond 2100.
3. Provide SLR and storm surge projections at more locations along the Californian coast and the Sacramento-San Joaquin Delta. This data is needed to produce more localized information about future flooding. In this study, we use hourly sea level projections at nine locations along the coast to drive our statewide 50m (~164ft) resolution simulation and proximate water level information for local tiles in the 5m (~16.4ft) resolution simulation. This statewide to local approximation from nine locations may cause some inaccuracies in the water levels used for the local tiles, and further over or underestimate flooding. In addition, no projection is readily available for the Delta, which limits our ability to conduct accurate simulation in this region.
4. Analyze coastal and inland flooding in one model to estimate the combined inundation of the two. Such analysis would greatly improve exposure estimates. In this study, we model coastal flooding driven by the highest sea levels and inland flooding driven by the highest rainfall intensities as separate phenomena. The sea level and rainfall

projections are time-dependent and their maximums may lag over time and space. Since our model has the capability of modeling these two types of flooding jointly, future research should strive to model them together over a long period of time (e.g. 20 years) and identify a specific time window (e.g. a 72-hour period) that produces the maximum flooding extent and depth.

5.3.2 Wildfire

1. Bridging the gap between wildfire behavior and damage to TFS assets is an area of future research. Our 5m (16.4ft) spatial resolution wildfire research models wildfire behavior, such as heat intensity, but does not indicate if heat intensities will disrupt product flows. This would involve research innovations regarding both asset vulnerability assessments and the development of asset-specific wildfire behavior hazards. Pipeline-specific wildfire behavior hazards research should aim to better understand the relationship between wildfire residency time, heat transfer, and the likelihood of damage to TFS assets located belowground. For example, pipeline vulnerability research should model a spatially variable threshold of fire intensity that would damage a pipeline, varying by pipeline depth and insulation. As with flooding hazards, linking flooding model output metrics to asset-specific damage typologies will help estimate loss related to damage or disruption, as well as further model the cascading impacts throughout the physical and organizational supply-and-distribution networks.
2. High spatial resolution wildfire behavior simulations could be improved with:
 - a. Object-based simulation software, as opposed to the pixel and vector-based software intended for regional scale analyses;
 - b. state-wide data indicating ecoregion specific wildfire fuel models, and corresponding fuel moisture parameter values for these models;
 - c. imagery and LiDAR data flown simultaneously and more frequently to limit land cover classification error and discrepancy between datasets.
3. To improve accuracy and utility of future projections of high-resolution wildfire behaviors, high-resolution vegetation change models driven by climate variability need to be developed and incorporated in wildfire behavior models.
4. Develop process-based wildfire projections, rather than statistical projections based on historical data, to improve accuracy of regional wildfire likelihood estimations.

5.3.3 Stakeholder

1. Model the TFS's exposure beyond the sector's intraconnectivity by including its interconnections to, and interdependencies on, other critical infrastructures. Literature on the vulnerability of critical infrastructures as well as the TFS stakeholder engagement results consistently demand the inclusion of supporting infrastructures that TFS assets depend on (as vital inputs) such as power, telecommunications, water, hydrogen, natural gas, and other factors.

With more detailed information from stakeholders, a network model could be built that enables the modeling of the (cascading) effects of disruptions at individual sites throughout the entire State. More industry cooperation would be needed to identify such connections, to rate significance, to identify alternative pathways, etc.

2. Develop a reporting system of damage and disruption of the different TFS nodes and links identified. Encourage a systemic reporting of such incidents that are not solely dependent on hazardous materials spillage. This will ensure that the variety of organization-specific incident and risk metrics of the TFS are shared with the California regulatory and safety agencies. Furthermore, it is essential for inter-organizational cooperation for procedural and policy improvement.
3. Identify and disseminate a comprehensive review of successes and failures of different TFS core, dependent, and knowledgeable organizations implementing resiliency measures in response to extreme weather hazards (e.g. Meer, Cooper, Warner, Adams-Morales, & Steendam, 2008).
4. Conduct cost-benefit analyses comparing the cost of implementing resilience and adaptation measures to the risk-abating benefits of these investments. For flooding, this could involve evaluating the cost of building levees and the benefits of evading potential damages. For wildfire, this would weigh the potential exposure reducing benefit of mitigation against the cost of mitigation. Quantifying the costs and benefits would lay the foundations for inter-organizational collaboration, which would leverage a combined willingness to pay where multiple organizations have neighboring assets that can benefit from the same risk reducing investment.
5. Expand the stakeholder engagement process with more in-depth discussions and increase the population sample size to obtain a higher coverage of TFS core, dependent, and knowledgeable organizations.

5.4 Value of Our Methods

This subsection highlights the value of the methods employed by the study and how they can be carried further in future research.

5.4.1 Flooding

Our coastal and inland flooding simulation link closely with different time periods and climate scenarios; therefore, our simulation shows what the flooding is like under a specific period and the uncertainty across different climate scenarios. This is particularly applicable in planning that is often associated with specific time frames.

Previous coastal flooding studies (Barnard et al., 2014; Biging, Radke, & Lee, 2012; Knowles, 2009, 2010; Radke et al., 2014) typically produced and adopted flooding maps under different return-interval storms combined with incremental SLR (e.g. every 0.5 m) that did not closely associate with specific climate scenarios or infrastructure planning horizons, which are often decadal time periods. While this incremental approach provides the flexibility to adapt itself to various and emerging climate scenarios, it may not sufficiently show what the flooding is like under a specific scenario and planning horizon, as well as the uncertainties introduced by different scenarios and how the uncertainties change over time. Our simulation by time periods

and climate scenarios overcomes these issues in the incremental approach and better informs planning decisions towards a specific planning horizon.

Our fine spatial resolution simulation provides detailed flooding exposure at the asset level and better informs stakeholders. In coastal flooding, the fine resolution model (5m/~16.4ft), including buildings and other ground objects, refines the results of the 50m (~164ft) resolution model and therefore provides more detail for stakeholders about flooding exposure of their local assets. In addition, the fine spatial resolution model may more accurately estimate flooding as it better captures the changes in topography and potential water flow pathways. Moreover, combined with our fine spatial resolution (5m/~16.4ft) simulation of inland water flows from watersheds based on future predictions of precipitation, our results provide a more complete assessment of asset exposure (from inland and coastal sources).

5.4.2 Wildfire

The Modeled Wildfire Threat Rating system we developed from Westerling's (forthcoming) wildland fire futures can be further used to assess the exposure of the California TFS asset containing regions to hazards and threats associated with large wildfires over the remainder of the twenty-first century.

For TFS asset managers, the benefits of our fine spatial resolution (5m/~16.4ft) analysis of potential wildfire behavior and heat exposure are that this detailed analysis allows them to assess their own vulnerabilities and damage scenarios, develop targeted risk mitigation strategies, and prepare for wildfire events where it will be difficult for firefighting resources to control wildfire around the asset. The model precision also enables asset managers to use the model as a tool to prioritize wildfire risk mitigation investments.

5.4.3 Stakeholder

The stakeholder engagement process is a continuous and cyclical process. The study disseminates information from flood and wildfire models to interested and targeted stakeholder organizations. It also gathers knowledge of ownership and operators of TFS assets, as well as regulators and researchers of this intricate sector, which in turn feeds into the quality and usefulness of the models. Harnessing TFS stakeholders experience and knowledge was a crucial step in this project for three primary reasons:

1. It helps identify the sector's key assets, their modes of connection, and general flow of fuel commodities to create a geo-physical infrastructure network that corresponds to the TFS supply chain. To our knowledge, this is a first-time effort to conceptualize and topologically model the TFS in California.
2. It is necessary to assess stakeholder reactions to our model's results. This is a major step in the engagement process as it promotes:
 - a. Communication and usefulness of the climate science applied in the methods of this project by adapting the modeling results to sector-specific or organization-specific issues.
 - b. A better understanding of the vulnerability of the sector by assessing the damage or disruption propensities of TFS assets when they intersect with flooding and wildfire hazardous projected areas. Exposure does not automatically translate to damage or disruption and the stakeholders responsible for managing the

different parts of the sector have the richest knowledge on how these projected hazards might impact their operations.

- c. Voicing some of the sector's concerns in relation to flooding and wildfire threats in the near- and long-term.

From a long-term perspective, it promotes awareness of flooding and wildfire threats to the industry and pools knowledge and experience from different TFS stakeholders that can induce co-solutions to issues that affect various levels of the industry and society.

6: References

- Acclimatise. (2009). *Oil and gas: Understanding the investment implications of adapting to climate change* (No. USS001/1).
- American Petroleum Institute. (2016). *Oil and Natural Gas Industry Preparedness Handbook* (No. Version 3.0). Washington, D.C. Retrieved from <http://www.americanpetroleuminstitute.net/news-policy-and-issues/safety-and-system-integrity/oil-gas-industry-preparedness-handbook>
- Andrews, P. L., Heinsch, F. A., and Schelvan, L. (2011). *How to Generate and Interpret Fire Characteristics Charts for Surface and Crown Fire Behavior*. Fort Collins, CO: U.S. Department of Agriculture, Forest Service, Rocky Mountain Research Station. Retrieved from <https://www.fs.usda.gov/treearch/pubs/37380>.
- Bahreian, A., Borges, E., Gage, J., McBride, B., Schremp, G., van der Werf, Y., & Yowell, G. (2015). *Staff Draft Report, Transportation Energy Demand Forecast, 2016-2026* (No. CEC-200-2015-008-SD). California Energy Commission.
- Barnard, P. L., Ormond, M. van, Erikson, L. H., Eshleman, J., Hapke, C., Ruggiero, P., ... Foxgrover, A. C. (2014). Development of the Coastal Storm Modeling System (CoSMoS) for predicting the impact of storms on high-energy, active-margin coasts. *Natural Hazards*, 74(2), 1095–1125. <https://doi.org/10.1007/s11069-014-1236-y>
- Beheshtian, A., Donaghy, K. P., Gao, H. O., Safaie, S., & Geddes, R. (2018). Impacts and implications of climatic extremes for resilience planning of transportation energy: A case study of New York city. *Journal of Cleaner Production*, 174, 1299–1313.
- Beheshtian, A., Donaghy, K. P., Geddes, R. R., & Rouhani, O. M. (2017). Planning resilient motor-fuel supply chain. *International Journal of Disaster Risk Reduction*, 24, 312–325.
- Biging, G. S., Radke, J. D., & Lee, J. H. (2012). *Impacts of predicted sea-level rise and extreme storm events on the transportation in the San Francisco Bay Region* (No. CEC - 500 - 2012 - 040). California Energy Commission.
- Caine, N. (1980). The Rainfall Intensity: Duration Control of Shallow Landslides and Debris Flows. *Geografiska Annaler. Series A, Physical Geography*, 62(1/2), 23–27. <https://doi.org/10.2307/520449>
- CAL FIRE. (2017, April). *AB 864 Oil Spill Response: Environmentally And Ecologically Sensitive Areas*. Presented at the Pipeline Safety Conference, Long Beach. Retrieved from <http://osfm.fire.ca.gov/codedevelopment/pdf/title19/Pipeline%20Annual%20Conference%20AB%20864%20presentation.pdf>
- California Department of Fish and Wildlife. (2017a, October 19). History of OSPR. California Department of Fish and Wildlife. Retrieved from <https://www.wildlife.ca.gov/OSPR/About/History>
- California Department of Fish and Wildlife. (2017b, November 7). About OSPR. California Department of Fish and Wildlife. Retrieved from <https://www.wildlife.ca.gov/OSPR/About>

- California Department of Transportation. (2012). *California Military Use Airports*. Retrieved from http://www.dot.ca.gov/hq/tsip/gis/datalibrary/Metadata/Airp_military.html
- California Department of Transportation. (2016a). *California Public Use Airports*. Retrieved from <http://www.dot.ca.gov/hq/tsip/gis/datalibrary/Metadata/Airports.html>
- California Department of Transportation. (2016b). *Truck Network (2016)*. Retrieved from <http://www.dot.ca.gov/hq/tsip/gis/datalibrary/Metadata/Trknet.html>
- California Department of Transportation. (2018). *Caltrans Climate Change Vulnerability Assessments*. District 4 Technical Report, January 2018. Retrieved from http://www.dot.ca.gov/transplanning/ocp/docs/rCT_D4_Technical_Report_VerAL.pdf.
- California Energy Commission. (2016a). *California Oil Refinery History*. Retrieved from http://www.energy.ca.gov/almanac/petroleum_data/refinery_history.html
- California Energy Commission. (2016b). *Crude Oil Imports by Rail 2016*. Retrieved from http://www.energy.ca.gov/almanac/petroleum_data/statistics/2016_crude_by_rail.html
- California Energy Commission. (2017a). *California Retail Fuel Outlet Annual Reporting (CEC-A15) Results*. Retrieved from http://www.energy.ca.gov/almanac/transportation_data/gasoline/piira_retail_survey.html
- California Energy Commission. (2017b). *Oil Supply Sources to California Refineries*. Retrieved from http://www.energy.ca.gov/almanac/petroleum_data/statistics/crude_oil_receipts.html
- California Public Utilities Commission. (2017). *CPUC Fire Safety Rulemaking (R.15-05-006) & Fire Maps*. California Public Utilities Commission. Retrieved from <http://cpuc.ca.gov/general.aspx?id=6442454972>
- Campbell, R. H. (1974). *Soil Slips, Debris Flows, and Rainstorms in the Santa Monica Mountains and Vicinity, Southern California* (USGS Professional Paper No. 851). Reston, VA: U. S. Geological Survey.
- Cannon, S. H., Gartner, J. E., Rupert, M. G., & Michael, J. A. (2004). *Emergency Assessment of Debris-flow Hazards from Basins Burned by the Cedar and Paradise Fires of 2003, Southern California* (USGS Open-File Report No. 04-1011). Reston, VA: U.S. Geological Survey.
- Carlson, C., Goldman, G., & Dahl, K. (2015). *Stormy Seas, Rising Risks: What Investors Should Know About Climate Change Impacts at Oil Refineries*. Union of Concerned Scientists. Retrieved from <https://www.ucsusa.org/sites/default/files/attach/2015/02/stormy-seas-rising-risks-ucs-2015.pdf>
- Castillo, A. (2018, January 9). *Mudslides around Thomas fire burn area exacerbated by 11 months of dry conditions*. *Los Angeles Times*. Retrieved from <http://www.latimes.com/la-me-southern-california-storm-live-mudslides-around-thomas-fire-burn-area-1515541591-htmistory.html>

- Cayan, D. R., Kalansky, J., Iacobellis, S., & Pierce, D. (2016). *Creating Probabilistic Sea Level Rise Projections to support the 4th California Climate Assessment* (No. 16- IEPR-04). California Energy Commission. Retrieved from http://docketpublic.energy.ca.gov/PublicDocuments/16-IEPR-04/TN211806_20160614T101823_Creating_Probabilistic_Sea_Level_Rise_Projections.pdf
- City and County of San Francisco. (2016). *San Francisco Sea Level Rise Action Plan*. Retrieved from http://default.sfplanning.org/plans-and-programs/planning-for-the-city/sea-level-rise/160309_SLRAP_Final_ED.pdf
- Cleveland, G. B. (1973). Fire + rain = mudflows, Big Sur. *California Geology*, 26, 127-135.
- Cragg, C., Burton, A., Feinberg, E., & Schaik, J. (2011). *Energy Fundamentals: Understanding the Oil & Gas Industries*. Energy Intelligence.
- Cruz, A. M. (2012). Challenges in Natech Risk Reduction. *Revista de Ingeniería*, (37), 79-86.
- Cruz, A. M., & Krausmann, E. (2013). Vulnerability of the oil and gas sector to climate change and extreme weather events. *Climatic Change*, 121(1), 41-53. <https://doi.org/10.1007/s10584-013-0891-4>
- Davidson, C., Newes, E., Schwab, A., & Vimmerstedt, L. (2014). An overview of aviation fuel markets for biofuels stakeholders. *National Renewable Energy Laboratory*, Retrieved September, 5, 2014.
- DeBano, L. F. (1989). Effects of fire on chaparral soils in Arizona and California and postfire management implications.
- DeBano, L. F. (2000). The role of fire and soil heating on water repellency in wildland environments: a review. *Journal of Hydrology*, 231, 195-206.
- Division of Oil, Gas, and Geothermal Resources. (2016). Well Count and Production of Oil, Gas, and Water By County - 2016. Retrieved from ftp://ftp.consrv.ca.gov/pub/oil/annual_reports/2016/Wells_and_Production_by_County_2016.pdf
- Division of Oil, Gas, and Geothermal Resources. (2017). *California Oil and Gas Fields* (No. TR10-12). California Department of Conservation. Retrieved from http://www.conservation.ca.gov/dog/pubs_stats/Pages/technical_reports.aspx
- Division of Oil, Gas, and Geothermal Resources. (2018). *All Wells.Shp*. GIS Mapping. California, 2018. Retrieved from <http://www.conservation.ca.gov/dog/maps/Pages/GISMapping2.aspx>.
- Dolan, J. (2018, January 21). Highway 101 in Santa Barbara County Reopens nearly two weeks after a massive mudslide. *Los Angeles Times*. Retrieved from <http://www.latimes.com/local/lanow/la-me-ln-freeway-reopens-20180121-story.html>
- DWR, & CCTAG. (2015). *Perspectives and Guidance for Climate Change Analysis*. California Department of Water Resources (DWR), Climate Change Technical Advisory Group (CCTAG).

- Ebinger, J. O., & Vergara, W. (2011). *Climate impacts on energy systems: key issues for energy sector adaptation*. Washington, D.C: World Bank.
- Energy Intelligence Research. (2011). *Energy Fundamentals: Understanding The Oil & Gas Industries* (No. 5th Edition) (p. 190p). New York.
- Finney, M. A. (2006). An overview of FlamMap fire modeling capabilities.
- Girgin, S., Krausmann, E., European Commission, Joint Research Centre, & Institute for the Protection and the Security of the Citizen. (2015). *Lessons learned from oil pipeline natech accidents and recommendations for natech scenario development: final report*. Luxembourg: Publications Office. Retrieved from <http://bookshop.europa.eu/uri?target=EUB:NOTICE:LBNA26913:EN:HTML>
- Goldthau, A., & Sovacool, B. K. (2012). The uniqueness of the energy security, justice, and governance problem. *Energy Policy*, 41, 232–240. <https://doi.org/10.1016/j.enpol.2011.10.042>
- Gordon. Sea level rise planning: database., Pub. L. No. AB 2516, § 30961, Division 20.6 Public Resources Code (2014). Retrieved from http://leginfo.legislature.ca.gov/faces/billTextClient.xhtml?bill_id=201320140AB2516
- Hagberg, A. A., Schult, D. A., & Swart, P. J. (2008). Exploring network structure, dynamics, and function using NetworkX. In *Proceedings of the 7th Python in Science Conference*, (Pasadena, CA USA), 11–15.
- Haile, A. T., & Rientjes, T. H. M. (2005). Effects of LiDAR DEM resolution in flood modelling: a model sensitivity study for the city of Tegucigalpa, Honduras. *Isprs Wg Iii/3, Iii/4, 3*, 12–14.
- Hamilton, T. M. (2015, May 12). New supply patterns and additional disruptions push California gasoline prices higher. *Today in Energy*. Retrieved from <https://www.eia.gov/todayinenergy/detail.php?id=21192>
- Hanson, J. C. (2009). *Reclamation District 341, Sherman Island five year plan* (No. SH 08-3.0). Retrieved from http://ccrm.berkeley.edu/resin/pdfs_and_other_docs/background-lit/hanson_5yr-plan.pdf
- Herkenhoff, L. (2014a). *A profile of the oil and gas industry: resources, market forces, geopolitics, and technology* (First edition). New York, NY (222 East 46th Street, New York, NY 10017): Business Expert Press.
- Herkenhoff, L. (2014b). *A profile of the oil and gas industry: resources, market forces, geopolitics, and technology* (First edition). New York, NY (222 East 46th Street, New York, NY 10017): Business Expert Press.
- Hilyard, J. (2012). *The Oil & Gas Industry: A Nontechnical Guide*. PennWell Corporation. Retrieved from <http://site.ebrary.com/lib/berkeley/reader.action?docID=10605558&ppg=1>
- Ingebritsen, S. E., Ikehara, M. E., Galloway, D. L., & Jones, D. R. (2000). *Delta subsidence in California; the sinking heart of the state* (No. Fact Sheet 005-00). U.S. Geological Survey. Retrieved from <http://pubs.usgs.gov/fs/2000/fs00500/>

- IPIECA. (2013). *Addressing adaptation in the oil and gas industry*. Retrieved from <http://www.ipieca.org/news/addressing-adaptation-in-the-oil-and-gas-industry/>
- Jacoby, D. (2012). *Optimal Supply Chain Management in Oil, Gas and Power Generation*. PennWell Corporation. Retrieved from <http://site.ebrary.com/lib/berkeley/reader.action?docID=10626936>
- Jakob, M., & Hungr, O. (2005). *Debris-flow hazards and related phenomena*. Berlin ; New York: Springer.
- Jaradat, R. M., & Keating, C. B. (2014). Fragility of oil as a critical infrastructure problem. *International Journal of Critical Infrastructure Protection*, 7(2), 86–99. <https://doi.org/10.1016/j.ijcip.2014.04.005>
- Ju, Y., Hsu, W.-C., Radke, J. D., Fournier, W., Lang, W., Hoes, O., ... Maier, W. (2017). Planning for the Change: Mapping Sea Level Rise and Storm Inundation in Sherman Island Using 3Di Hydrodynamic Model and LiDAR. In P. (Vonu) Thakuria, N. Tilahun, & M. Zellner (Eds.), *Seeing Cities Through Big Data* (pp. 313–329). Springer International Publishing. https://doi.org/10.1007/978-3-319-40902-3_18
- Kazemi, Y., & Szmerekovsky, J. (2015). Modeling downstream petroleum supply chain: The importance of multi-mode transportation to strategic planning. *Transportation Research Part E: Logistics and Transportation Review*, 83, 111–125. <https://doi.org/10.1016/j.tre.2015.09.004>
- Knowles, N. (2009). *Potential inundation due to rising sea levels in the San Francisco Bay region* (California Climate Change Center Report Series No. CEC-500-2009-023-F). California Energy Commission. Retrieved from <http://www.energy.ca.gov/2009publications/CEC-500-2009-023/CEC-500-2009-023-D.PDF>
- Knowles, N. (2010). Potential Inundation Due to Rising Sea Levels in the San Francisco Bay Region. *San Francisco Estuary and Watershed Science*, 8(1). Retrieved from <http://escholarship.org/uc/item/8ck5h3qn>
- Lawrence Livermore National Laboratory. (2014). California Energy Consumption in 2014: ~7059 Trillion BTU. Retrieved from https://flowcharts.llnl.gov/content/assets/images/charts/Energy/Energy_2014_United-States_CA.png
- Lee, J. C., Medina, J., & Parlapiano, A. (2018, January 16). Identifying the Causes of the California Mudslides. Retrieved February 12, 2018, from <https://www.nytimes.com/interactive/2018/01/16/us/map-california-mudslides.html>
- Lindner, C., Burla, P., & Vallée, D. (2018). Graph-Theory-Based Modeling of Cascading Infrastructure Failures. *Journal of Extreme Events*, 1750012. <https://doi.org/10.1142/S2345737617500129>
- Los Angeles Times Staff. (2018, January 17). Who they were: The victims of the Montecito mudslides. *Los Angeles Times*. Retrieved from

<http://www.latimes.com/local/california/la-me-montecito-mudslide-victims-stories-20180112-htlstory.html>

- Lulic, L. (2015). Governance in the Oil and Gas Industry: Past Approaches, New Challenges. In *International OFEL Conference on Governance, Management and Entrepreneurship* (p. 1153). Centar za istrazivanje i razvoj upravljanja doo.
- McDonald, B. C., Gouw, J. A. de, Gilman, J. B., Jathar, S. H., Akherati, A., Cappa, C. D., ... Trainer, M. (2018). Volatile chemical products emerging as largest petrochemical source of urban organic emissions. *Science*, 359(6377), 760–764. <https://doi.org/10.1126/science.aaq0524>
- McDonald, L. (2018). Post-fire mudslide problems aren't new and likely to get worse. *The Conversation*. Retrieved from <https://theconversation.com/post-fire-mudslide-problems-arent-new-and-likely-to-get-worse-90048>
- McGee, T., McFarlane, B., & Tymstra, C. (2015). Chapter 3: Wildfire. A Canadian Perspective. *Wildfire Hazards, Risks, and Disasters*, 35–58. <https://doi.org/10.1016/B978-0-12-410434-1.00003-8>
- Meer, J.W. van der, Cooper, C., Warner, M.J., Adams-Morales, H., and Steendam, G. J. (2008). The Success of Hurricane Protection around Chevron's Refinery at Pascagoula, MS, during Katrina. *Gulf Coast Hurricane Preparedness, Response, Recovery & Rebuilding*.
- Meigs, G. W., Zald, H. S. J., Campbell, J. L., Keeton, W. S., & Kennedy, R. E. (2016). Do insect outbreaks reduce the severity of subsequent forest fires? *Environmental Research Letters*, 11(4), 045008. <https://doi.org/10.1088/1748-9326/11/4/045008>
- Miesner, T., & Leffler, W. (2006). *Oil and Gas Pipelines in Nontechnical Language*. PennWell Corporation. Retrieved from <http://site.ebrary.com/lib/berkeley/reader.action?docID=10201497>
- Miller, R. A. (2009). There's infrastructure and ...critical infrastructure. *International Journal of Critical Infrastructure Protection*, 2(1–2), 3–4. <https://doi.org/10.1016/j.ijcip.2009.02.003>
- Moss, R. H., Edmonds, J. A., Hibbard, K. A., Manning, M. R., Rose, S. K., van Vuuren, D. P., ... Wilbanks, T. J. (2010). The next generation of scenarios for climate change research and assessment. *Nature*, 463(7282), 747–756. <https://doi.org/10.1038/nature08823>
- Mount, J., & Twiss, R. (2005). Subsidence, Sea Level Rise, and Seismicity in the Sacramento–San Joaquin Delta. *San Francisco Estuary and Watershed Science*, 3(1). Retrieved from <http://escholarship.org/uc/item/4k44725p>
- National Academies of Sciences, Engineering, and Medicine. (2017a). *Designing Safety Regulations for High-Hazard Industries*. Washington, D.C.: Transportation Research Board. <https://doi.org/10.17226/24907>
- National Academies of Sciences, Engineering, and Medicine. (2017b). *Safely Transporting Hazardous Liquids and Gases in a Changing U.S. Energy Landscape*. Washington, D.C.: Transportation Research Board. <https://doi.org/10.17226/24923>

- National Academy of Sciences. (2017). State Energy System California. Retrieved October 15, 2017, from <http://needtoknow.nas.edu/energy/interactive/california-energy-system/>
- Neumann, J. E., & Price, J. (2009). *Adapting to Climate Change: The Public Policy Response - Public Infrastructure* (Resources for the Future Report) (p. 43).
- Office of Governor Edmund G. Brown, Jr. (2015, April 29). Governor Brown Establishes Most Ambitious Greenhouse Gas Reduction Target in North America. Retrieved from <https://www.gov.ca.gov/2015/04/29/news18938/>
- Pasteris, P. (2010). Adaptation in the Oil and Gas Industry to Projected Impacts of Climate Change. *SPE International Conference on Health, Safety and Environment in Oil and Gas Exploration and Production*. Retrieved from <https://libproxy.berkeley.edu/login?url=http%3a%2f%2fsearch.ebscohost.com%2flogin.aspx%3fdirect%3dtrue%26db%3dedsonp%26AN%3dedsonp.SPE.126307.MS%26site%3dedsonp>
- Perez, P. (2005, May). *Ethanol in California*. Presented at the Platts Ethanol Finance & Investment Conference, Chicago, Illinois. Retrieved from <http://www.energy.ca.gov/2005publications/CEC-999-2005-014/CEC-999-2005-014.PDF>
- Pierce, D., Cayan, D. R., & Dehann, L. (2016). *Creating Climate projections to support the 4th California Climate Assessment* (No. 16- IEPR-04). California Energy Commission. Retrieved from http://www.energy.ca.gov/2016_energypolicy/documents/2016-06-21_workshop/2016-06-21_documents.php
- Pierce, D. W., Cayan, D. R., & Thrasher, B. L. (2014). Statistical Downscaling Using Localized Constructed Analogs (LOCA). *Journal of Hydrometeorology*, 15(6), 2558–2585. <https://doi.org/10.1175/JHM-D-14-0082.1>
- Pipeline and Hazardous Materials Safety Administration. (2017). National Pipeline Mapping System. Retrieved from <https://www.npms.phmsa.dot.gov/GeneralPublic.aspx>
- Port of Long Beach. (2017). Tesoro Logistics Operations LLS - Pier T. Retrieved from http://www.polb.com/economics/cargotenant/liquid/tesoro_piert.asp
- Radke, J. D., Biging, G. S., Schimdt-Poolman, M., Foster, H., Roe, E., Ju, Y., ... Reeves, I. (2014). *Assessment of Bay Area Gas Pipeline Vulnerability to Climate Change* (No. CEC-500-11-016). California Energy Commission.
- Rinaldi, S. M., Peerenboom, J. P., & Kelly, T. K. (2001). Identifying, understanding and analyzing critical infrastructure interdependencies. *Institute of Electrical and Electronics Engineers Control Systems Magazine*, 21(6), 11–25. <https://doi.org/10.1109/37.969131>
- Rodrigue, J.-P., Comtois, C., & Slack, B. (2017). *The Geography of Transport Systems* (4th ed.). Routledge.
- Sahebi, H., Nickel, S., & Ashayeri, J. (2014). Strategic and tactical mathematical programming models within the crude oil supply chain context – A review. *Computers & Chemical Engineering*, 68, 56–77. <https://doi.org/10.1016/j.compchemeng.2014.05.008>

- Schremp, G. (2014, May). *California Transportation Fuel Overview & Crude Oil Trends*. Presented at the OSPR- Spill Prevention and Response Day, California Maritime Academy, Vallejo, CA.
- Schremp, G. (2016a, September). *Odd-Even Fuel Purchasing and Minimum Fuel Purchases*. Presented at the Western Regional Emergency Fuel Coordination Meeting, "Near-term Actions Intended to Decrease Demand/Diminish Panic-Buying and Hoarding of Transportation Fuels" Session, Sacramento, California. Retrieved from <https://www.naseo.org/event?EventID=1435>
- Schremp, G. (2016b, September). *PADD 5 & California Transportation Fuel Overview*. Presented at the Western Regional Emergency Fuel Coordination Meeting, Sacramento, California. Retrieved from <https://www.naseo.org/Data/Sites/1/schremp-1.pdf>
- Schremp, G. (2017a, June). *California Fuel Overview & Emergency Fuels Set-Aside Program*. Presented at the California Utilities Emergency Association Annual Meeting, Mather, California. Retrieved from <http://cms.capitoltechsolutions.com/ClientData/CUEA/documents/CaliforniaFuelSetAsideProgramGordonSchrempFinal20170621.pdf>
- Schremp, G. (2017b, October). *California Fuel Overview & Emergency Fuels Set-Aside Program*. Presented at the 2017 San Francisco Fleet Week Lifeline Interdependencies - Fuel Session.
- Scott, J. H., & Burgan, R. E. (2005). Standard fire behavior fuel models: a comprehensive set for use with Rothermel's surface fire spread model. *Gen. Tech. Rep. RMRS-GTR-153*. Fort Collins, CO: U.S. Department of Agriculture, Forest Service, Rocky Mountain Research Station. 72 P., 153. <https://doi.org/10.2737/RMRS-GTR-153>
- Shen, S., Feng, X., & Peng, Z. R. (2016). A framework to analyze vulnerability of critical infrastructure to climate change: the case of a coastal community in Florida. *Natural Hazards*, 84(1), 589–609. <https://doi.org/10.1007/s11069-016-2442-6>
- Sleeter, B. M., Wilson, T. S., Sharygin, E., & Sherba, J. T. (2017). Future Scenarios of Land Change Based on Empirical Data and Demographic Trends: LAND USE PROJECTIONS FOR CALIFORNIA. *Earth's Future*. <https://doi.org/10.1002/2017EF000560>
- Stelling, G. S. (2012a). Quadtree flood simulations with sub-grid digital elevation models. *Proceedings of the ICE - Water Management*, 165(10), 567–580. <https://doi.org/10.1680/wama.12.00018>
- Stelling, G. S. (2012b). Quadtree flood simulations with sub-grid digital elevation models. *Proceedings of the ICE - Water Management*, 165(10), 567–580. <https://doi.org/10.1680/wama.12.00018>
- Transportation Research Board, & National Academies of Sciences, E., and Medicine. (2017). *Safely Transporting Hazardous Liquids and Gases in a Changing U.S. Energy Landscape*. Washington, DC: The National Academies Press. <https://doi.org/10.17226/24923>

- U.S. Department of Energy. (2010). *Hardening and Resiliency: U.S. Energy Industry Response to Recent Hurricane Seasons*. Retrieved from <https://www.oe.netl.doe.gov/docs/HR-Report-final-081710.pdf>
- U.S. Department of Energy. (2014). *U.S. Fuels Supply Infrastructure Vulnerabilities to Natural and Physical Threats* (United States Fuel Resiliency No. Volume II) (p. 103). U.S. Department of Energy, Office of Energy Policy and Systems Analysis. Retrieved from <https://energy.gov/sites/prod/files/2015/04/f22/QUER%20Analysis%20-%20United%20States%20Fuel%20Resiliency%20Volume%20II.pdf>
- U.S. Department of Transportation. (2007). *Financing Freight Improvements*. Retrieved from <https://ops.fhwa.dot.gov/freight/publications/freightfinancing/freightfinancing.pdf>
- U.S. Department of Transportation. (2016). *Ports*. Geospatial at the Bureau of Transportation Statistics. Retrieved from http://osav-usdot.opendata.arcgis.com/datasets/490e1e06b54b4a5bb1e58523a5d546a7_0
- U.S. Department of Transportation, F. H. A. (2015). *Climate Change Adaptation Guide for Transportation Systems Management, Operations and Maintenance*.
- U.S. Energy Information Administration. (2013). *Weather and other events can cause disruptions to gasoline infrastructure and supply*. Retrieved from <https://www.eia.gov/todayinenergy/detail.php?id=9811#>
- U.S. Energy Information Administration. (2015a). *West Coast Transportation Fuels Markets, PADD 5* (p. 66). Washington, D.C. Retrieved from https://www.eia.gov/analysis/transportationfuels/padd5/pdf/transportation_fuels.pdf
- U.S. Energy Information Administration. (2015b, September 30). *West Coast Transportation Fuels Markets*. Retrieved from <https://www.eia.gov/analysis/transportationfuels/padd5/>
- U.S. Energy Information Administration. (2016, January 20). *Hydrogen for refineries is increasingly provided by industrial suppliers*. Retrieved from <https://www.eia.gov/todayinenergy/detail.php?id=24612>
- U.S. Energy Information Administration. (2017a). *Refinery Capacity Report* (No. EIA-820). Retrieved from <https://www.eia.gov/petroleum/refinerycapacity/>
- U.S. Energy Information Administration. (2017b). *U.S. Energy Mapping System*.
- U.S. Energy Information Administration. (2017c, October 19). *California State Profile and Energy Estimates*. Retrieved from <https://www.eia.gov/state/analysis.php?sid=CA>
- U.S. Energy Information Administration. (2017d, November 30). *U.S. Crude Oil Imports*. Retrieved December 15, 2017, from https://www.eia.gov/dnav/pet/pet_move_impcus_a2_nus_epc0_im0_mbbldpd_a.htm
- Vermeire, M. (2012). *Everything You Need to Know About Marine Fuels*. Ghent, Belgium: Chevron Global Marine Products. Retrieved from <http://www.chevronmarineproducts.com/content/dam/chevron->

marine/Brochures/Chevron_EverythingYouNeedToKnowAboutFuels_v3_1a_DESKTOP.pdf

- Vuuren, D. P. van, Edmonds, J., Kainuma, M., Riahi, K., Thomson, A., Hibbard, K., ... Rose, S. K. (2011). The representative concentration pathways: an overview. *Climatic Change*, 109(1-2), 5. <https://doi.org/10.1007/s10584-011-0148-z>
- Wells, W. G. (1987). The effects of fire on the generation of debris flows in southern California. In *Reviews in Engineering Geology* (Vol. 7, pp. 105-114). Geological Society of America. <https://doi.org/10.1130/REG7-p105>
- Westerling, A. L. (forthcoming). Wildfire Scenario Projections in California's Fourth Climate Change Assessment. 4th Assessment report or white paper.
- Western States Petroleum Association. (2017, April 5). California Fuel Facts. Retrieved October 6, 2017, from <https://www.wspa.org/resources/california-fuel-facts/>
- Williams. AB-864 Oil spill response: environmentally and ecologically sensitive areas., Pub. L. No. AB 864, § 51013.1 (2015). Retrieved from https://leginfo.ca.gov/faces/billNavClient.xhtml?bill_id=201520160AB86

APPENDIX A: Transportation Fuel Sector

A.1 Introduction: Steps Toward Conceptualization

The TFS conceptual model that this project develops has two functions: 1.) the identification of key oil and transportation assets that we overlay with hazard models to map the exposure of the sector to wildfire and flooding; and, 2.) the identification of key organizations in the sector to guarantee minimum representation of the major players during our stakeholder engagement process.

There is no formal definition of what constitutes the TFS, much less what the TFS represents at the California state level. The main sources driving our conceptualization of the TFS include literature on the oil supply and distribution chain in general and California specific supply and distribution information from our engagement with sector owners, operators, and regulators (Chapter 4; Appendix E).

Section A2 describes the process of building the geophysical TFS dataset which is then used for the exposure modeling. The dataset elements are based on the developed conceptual model, which is validated with input from field specialists. Then we identify Geographic Information System (GIS) datasets that contain the different key TFS assets represented in the conceptual model (Main Report **Figure 2**).

Specifics on this complex supply and demand chain in California are not easily accessible through the literature or open source GIS information. Thus, we obtain California TFS data partially through open-source government GIS datasets and partially through the National Pipeline Mapping System (NPMS) restricted database. This project's stakeholder engagement process is another primary source of information, allowing us to understand the crucial assets in the sector and their connections from experts in the field.

Based on the geophysical TFS assets database, Section A3 describes how this information can then be used to simulate routing possibilities between critical TFS assets. This is done to show how the transport of a commodity could potentially be "re-routed" in case exposure to wildfire and/or flooding deems a certain asset in the TFS unusable. The example given focuses specifically on the effect of flood inundation in the San Francisco Bay Area.

A.2 Data Sources and Discrepancies

The various physical TFS assets can be grouped into two essential categories, links and nodes. Links represent the different modes of transporting product along the network, such as waterways, railways, pipelines and roads. While nodes represent specific locations where loading, shipment, storage or processing of fuel products occur (e.g. refineries and terminals).

To our knowledge, there have never been any attempts to model the TFS in California as an interconnected geospatial network. Thus, we process some of the layers in our analysis to respond to the needs of this project. These alterations included grouping two or more different data sources, filtering data by specific attributes, assessing conflicting information coming from different data sources, and adding or removing features from data sources. We perform most of the alterations to oil infrastructure node datasets because the data collection methods undertaken by the different agency sources were fiscally driven and did not necessarily

translate to the necessities of spatial modeling. The confidential nature of many of these datasets also added to the difficulty of assessing the discrepancies between them.

Another complication associated with building this dataset and compiling information from different sources stemmed from the loose definitions of key elements such as terminals and commodity types. For example, depending on the data source, the distinction between crude oil and petroleum products can be inconsistent. The volatility in ownership and operation of these key oil and transportation infrastructures, also increases the difficulty of maintaining database consistency. Despite these complications, each asset is explained in detail in the next section to provide maximum transparency in terms of what data sources are used to represent the real world interconnected TFS infrastructure for this study.

A.2.1 Nodes: Assets Where Commodities are Processed, Transferred and/or Stored

A.2.1.1 Refineries

The refinery layer in our model is comprised of data from two official sources: the U.S. Energy Information Administration (EIA) and the California Energy Commission (CEC). We processed the data to combine these two datasets and to include new refinery locations that were not spatially described by either of these sources.

The EIA creates an open source GIS database of individual U.S. oil refineries by state. They collect this information based on the Annual Refinery Report (Form EIA-80). We use their GIS shapefile dated January 2016 to identify location and ownership information for 18 operating and idle refineries in California (U.S. Energy Information Administration, 2017a).

The CEC's Transportation Data Unit maintains tables with information on California oil refineries, including location, capacity, historical ownership, status (operational, idle, or closed), and if the operational facilities produce California Air Resource Board (CARB) compliant gasoline or diesel (California Energy Commission, 2016a, 2017b). All this information is collected under the Petroleum Industry Information Reporting Act (PIIRA). According to the CEC, there are a total of 19 operational refinery facilities in the state (out of which 14 produce CARB diesel and/or gasoline), and three idle facilities that produce fuel products. **Table A 1** shows a list of the different refinery facilities in California based on the EIA and CEC data we compile for our TFS database. In total, the database counts 18 geospatial refineries that participate in the fuel production in California, 15 are operable and three are idle. Idle infrastructure is included in our database because according to the EIA, these facilities are not in operation but under active repair and capable of being placed in operation within 30-90 days.

The TFS database includes operational and idle refineries that produce either fuel commodities or intermediary refined crude oil (gasoil) that will be processed into fuel products by their counterpart refineries. Alon USA Energy owns and operates three refinery facilities but are sometimes considered as one unit because they work together to produce fuel (Alon USA, 2017). As this project's goal is to model wildfire and flooding exposure to TFS assets, their spatial characteristic as three separate units is taken into consideration in the final count. In addition, Phillips66 has four operational refineries that work as two units: The "Los Angeles Refineries" has a facility in Carson and in Wilmington, connected by a 5-mile pipeline system. The "San Francisco Refinery" has a facility in Rodeo and in Santa Maria, connected by a 200-mile pipeline system (Phillips 66, 2018).

Table A 1. Refinery count for California TFS database

California Refinery Facilities		Original Sources		Final count
		EIA	CEC	TFS
1	ALON USA Energy, Inc., Bakersfield Refinery*	x	x	x
2	ALON USA Energy, Inc., Long Beach Refinery*		x	x
3	ALON USA Energy, Inc., Paramount Refinery*	x	x	x
4	Chevron USA Inc., El Segundo Refinery	x	x	x
5	Chevron USA Inc., Richmond Refinery	x	x	x
6	DeMenno/Kerdoon, Compton Refinery **	x	x	
7	PBF Energy, Torrance Refinery	x	x	x
8	Greka Energy, Santa Maria Asphalt Refinery**	x	x	
9	Kern Oil & Refining Company, Bakersfield Refinery	x	x	x
10	Lunday Thagard Oil Company (World Oil), South Gate Refinery	x	x	
11	Phillips 66, Carson Refinery ***			x
12	Phillips 66, Rodeo Refinery	x	x	x
13	Phillips 66, Santa Maria Refinery ***		x	x
14	Phillips 66, Wilmington Refinery	x	x	x
15	San Joaquin Refining Company, Bakersfield	x	x	x
16	Shell Oil Products US, Martinez Refinery	x	x	x
17	Tesoro Refining & Marketing Co., Carson Refinery	x	x	x
18	Tesoro Refining & Marketing Co., Golden Eagle Martinez/Avon	x	x	x
19	Tesoro Refining & Marketing Co., Wilmington Refinery	x	x	x
20	Valero Energy, Benicia Refinery	x	x	x
21	Valero Energy, Wilmington Refinery		x	x
22	Valero Asphalt Refinery, Wilmington **	x	x	
23	Valero Asphalt Refinery, Benicia **	x	x	
TOTAL		18	22	18

*Included idle facilities

** Excluded facilities because they don't produce fuel products

***Included facilities because they half-process crude oil for their counterparts to complete the refining process

A.2.1.2 Terminals

The TFS terminal data layer is also composed of a variety of sources such as the EIA, the CEC, the California State Lands Commission (SLC) and the Excise Summary Terminal Activity Reporting System (ExSTAR) from the Internal Revenue Service.¹ A terminal facility may have various meanings or functionalities depending on the organization that works with them. They represent a very complex TFS layer because they are distinct functionally both by the mode involved as well as the commodities that are being transported (Rodrigue et al., 2017). In most

¹ According to the IRS website: "ExSTARS is a fuel reporting system developed with the cooperation of the IRS, U.S. Department of Transportation, States, and Motor Fuel Industry. The system details the movement of any liquid product into or out of an IRS approved terminal. Terminal Operators and Bulk Fuel Carriers are required to file monthly information reports. All receipts and disbursements of liquid products to and from an approved terminal are reportable. This database is renewed yearly at: <https://www.irs.gov/businesses/small-businesses-self-employed/terminal-control-number-tcn-terminal-locations-directory>

cases, the term *terminal* is used for the description of key oil infrastructures without any clear definition of what it really stands for.

The variation on the definition of a terminal is rooted in organization-specific regulation and operation codes, for example, some organizations consider terminals as any fuel storage facility with a distinctive minimum capacity threshold, others consider them more as a transshipment facility independently of the existence of storage infrastructures, some consider only transloading facilities where there are a number of modes of fuel/crude oil transport available, also known as multimodality.

The differences are also related to the fact that a specific terminal for some organization are intermediary transshipment facilities while for others they represent end points of the supply chain.

For this project, we define terminals as: *any facility where liquid bulk transportation fuel commodity originates, terminates or is handled in the supply and distribution process.* Terminals can be transloading points within the same modal system, but in the case of the TFS, this concerns mainly multimodal transshipment facilities. A common characteristic of terminals is that the process of transferring a commodity from one mode of transportation to another usually requires a storage component. Which is why in most cases the TFS terminals are also depicted with storage tanks.

The EIA petroleum product terminal database used for this project defines Terminal facilities as a storage infrastructure with a “bulk shell storage capacity of 50 thousand barrels or more, and/or receives petroleum products by tanker, barge or pipeline” (U.S. Energy Information Administration, 2017a). This means they are mostly tracking very large petroleum products storage facilities, which does not include a series of terminals in California such as most of the Kinder Morgan, Inc. Terminals. According to the EIA (as of May 2016) there are 41 petroleum products bulk terminal facilities in California and these were included in our TFS terminal layer. Nevertheless, the EIA also keeps a Crude Oil Rail Terminal database with six facilities in California (as of November 2014), that were also added to the TFS Terminal database. In this case the terminals are referred as rail transloading facilities. Our stakeholder discussions show inconsistencies between the EIA (2014) rail crude oil terminals database and the operational status of commodities handled in these locations. The only crude oil rail terminal indicated to be in the San Francisco TFS hub area for example, has not been handling crude oil commodities in the last 10 years. It is, however, maintained in our database because it is used to unload other vital inputs to refineries such as ethanol and sulfuric acid. There are also 12 intermodal rail stations included in our TFS terminal database that are not directly transporting fuel commodities but TFS vital inputs (see CH 2.3.) instead. These 12 terminal points were obtained from Caltrans website (2013) and confirmed via our stakeholder discussion sessions.

According to the CEC there are approximately 100 terminals in the state that are represented as points that “receive petroleum and petroleum products by tanker, barge, pipeline, rail or truck.” To keep completing our TFS Terminal layer we added 10 out of 12 California Kinder Morgan Terminals that were not included in the EIA database. These 10 are digitized based on information available on Kinder Morgan, Inc.’s website (Kinder Morgan, Inc., 2017). Another important source of information to our TFS layer comes from the IRS Excerpt; it contained 84 terminals with ownership information with locations that were geocoded.

After cross-referencing these data sources, the TFS terminal layer summed to 111 terminal locations in California (**Table A 2**). There is still some improvement that can be made based on data sources from the SCL for the marine oil terminals and the California Department of Transportation (Caltrans) for the location of the rail intermodal freight terminals that handle biofuels. There is scarce information on bulk plants, which are terminals that are solely linked to roads and are used by trucking companies for the last stretch of the fuel delivery.

Table A 2. Terminal database sources and terminology overlaps

Source	Terminal terminology	Total in CA	TFS Terminal layer
<i>EIA</i>	Petroleum Products Bulk Terminals	41	41
<i>EIA</i>	Crude oil Rail Terminals	6	6
<i>Kinder Morgan</i>	Pipeline Terminals	12	10
<i>CEC</i>	Terminals	~100	N/A
<i>IRS</i>	Terminals	83	42
<i>SLC</i>	Marine Oil Terminal	34	N/A
<i>USDOT</i>	Port (transload fuel commodities)	213	N/A
<i>Caltrans/ CPUC</i>	Intermodal rail terminals (ethanol and other TFS vital inputs/outputs)	?	12
<i>Trucking companies</i>	Bulk plants (road mode fuel terminals)	?	?
Total		N/A	111

A.2.1.3 Ports or Docks

Ports are essential transloading facilities that are added as nodes connecting the maritime and land domains. These points can also be where some fuel commodities terminate, as they represent marine fuel distribution locations for vessels and regular fuel distribution location smaller watercrafts that are propeller-driven by gasoline or diesel for example. This dataset is from the U.S. Department of Transportation (USDOT)/Bureau of Transportation Statistics' National Transportation Atlas Database (U.S. Department of Transportation, 2017). The point locations within the dataset also contain a rich attribute table with information on the commodities that are handled in the different ports. For this project, we altered the original dataset to select only the ports that have commodities describes as petroleum feedstock, petroleum product or biofuels. This resulted in 213 ports in California that transload fuel commodities.

There is still a conceptual and geospatial overlap between our port layer and our and our terminal layer when referred to marine facilities. For instance, the CSL accounts for only 34 marine oil terminals in California, although there has not been found a clear definition on how their regulations frame marine terminals. For now, the assumption is that their regulatory framework is focused on defining engineering safety inspection and maintenance criteria for the prevention of oil spills. Therefore, they are most likely reporting to marine oil terminals with subsistent shell storage capacity and not including facilities where only transshipment is occurring. As for the DOT port database, they include all ports independently of the existence of storage facilities or the volume of commodities being handled, including smaller and/or intermittent fuel transshipment activities that are not of interest to other regulatory agencies.

One of difficulties inherent to the marine terminal and port layer overlap is related to complexity of governance forms or port management structures. These relate to the ownership

and operational responsibilities shared between the Port Authority and the Port holdings. The management structures of ports fluctuate differently from facility to facility between the weight of the private and public sectors. Furthermore, there is clustering of various private organizations in the management structures in ports that adds to the difficulty unifying different governmental datasets.

A.2.1.4 Airports

There are two types of airport location data: California public use airports and military airports both are created by Caltrans. Airports represent the end nodes of the jet fuel commodity subsystem. According to the California Department of Transportation (2016a) there are approximately 200 commercial airport facilities in the state that integrate the National Plan of Integrated Airport Systems and thus are classified for functions that require fuel storage facilities within its premises. Other primary jet fuel end points in the state are the 23 military airports in the state (California Department of Transportation, 2012).

A.2.1.5 Gas Stations

The locations of gas stations in the state of California are acquired through Google Places Application Programming Interface (as of November 2017). The method used for each query is center location plus search radius. Duplicate locations were removed, and the rest is converted to GIS point layer for future analysis and representation purposes.

A.2.1.6 Oil Fields and Oil Wells

The oil fields and oil wells represent one of the origins of the crude oil in the TFS. One third of the oil processed in California is originated from California's own production sources. Over 90% of this production comes from oil fields in Bakersfield. Both the oil fields (polygon layer) and oil wells (point layer) come from the California Department of Conservation, Division of Oil, Gas, and Geothermal Resources (Division of Oil, Gas, and Geothermal Resources, 2017, 2018). The oil fields were digitized from the map index pages contained within the three volumes of the following documents: California Oil & Gas Fields, Volume I - Central California (1998); Volume II - Southern, Central Coastal, Offshore California, (1992); Volume III - Northern California (1982). The original DOGGR oil well layer was filtered to obtain only wells that have an "active", "idle" or "new" status, excluding wells that are buried, plugged, and/or abandoned from our models. The original database does not allow for distinction between wells that produce primarily oil, primarily gas, or a mixture of the two.

A.2.2 Links: Key Transportation Assets Along, Over, or Through Which Commodities are Moved

A.2.2.1 Roadways

The road network dataset created for this project represents the functional road network in California. It was created using source data from ESRI Street Map Premium for ArcGIS. It includes updated road restriction attributes obtained from California Department of Transportation (2016b), related to transporting fuel products, transporting hazardous materials, and trucking in general, allowing for accurate modeling of how fuel delivery trucks travel along the road network.

A.2.2.2 Railways

The railway polyline layer was acquired through ArcGIS Business Analyst (2016). We clipped the dataset to the state boundary to get all the railway line data within California. In addition,

the processed dataset was later filtered by organization name (Union Pacific, Southern Pacific and Burlington Northern Santa Fe or BNSF) to get the freight railways that transport crude oil and ethanol.

A.2.2.3 Pipelines

The pipeline data layer was acquired through the National Pipeline Mapping System (Pipeline and Hazardous Materials Safety Administration, 2017) which is a dataset containing locations of and information about gas transmission and hazardous liquid pipelines and Liquefied Natural Gas (LNG) plants which are under the jurisdiction of the Pipeline and Hazardous Materials Safety Administration (PHMSA). To fit the scope of this research, this dataset was first filtered by selecting pipelines that only carry liquid fuels such as crude oil or jet fuel. Building on this selection, pipelines that are in service or inactive/idle status were filtered and added to the network model.

A.2.2.4 Waterways

The Navigable Waterways dataset is as of March 29, 2017, and is part of the U.S. Department of Transportation (USDOT)/Bureau of Transportation Statistics' (BTS's) National Transportation Atlas Database (NTAD). Since this is a comprehensive dataset, which covers the nation's navigable waterways, it was clipped to the state boundary to select out waterways within California.

A.2.3 Asset Area/ Polygon Information

The nature of the high-resolution hazard models of this project demands a richer spatial information for the key TFS assets. This means that the point data information needs to be transformed into polygon information. By having the boundaries for our TFS nodes and links the quality of the exposure assessment can be increased.

For the linkage assets, we achieve this by applying a buffer for the different right of ways amplitudes, depending on the transport infrastructure the right of ways varies from 15.24 to 45.72 m (50 to 150 ft.). For the node assets, the transformation process is a bit more complicated as the boundaries of these assets would correspond to the tax parcels in which they belong to. There is less homogeneity to what that translates to in terms of point to polygon transformations. The refineries' boundaries were created based on approximation from aerial images and open street maps information. We extract the terminal boundaries from the intersection of our point data with the most recent tax parcel information available for each county. The boundary information for both terminals and refineries present a margin of error that is derived from digitized approximation and variation of management models for different facilities. It is common to find a single tax parcel boundary that holds multiple TFS assets of different operators.

A.2.4 Possibilities for Enriching the TFS Layers

Based on our stakeholder engagement process and literature review the overview of critical assets of the system could be enriched by the addition of some TFS layers as key assets:

- Pipeline pumping and valve stations or any other aboveground appurtenances;
- Control rooms and other buildings hosting crucial system control software such as Supervisory control and data acquisition (SCADA); and
- Offshore/subsea pipeline connections to mainland infrastructure.

These layers are not included in this study because of time constraints to find and process the specific data, or because they are not open-source.

A.2.5 Summary of TFS layers

The above descriptions of the TFS asset data are summarized in **Table A 3**. They are organized according to how we have named them for modeling purposes. We give the type of data, the source of the data and an URL of the source (if applicable) with the date of the data.

Table A 3. Summary table with TFS layers and data sources

Layer name	Data type	Source	Asset numbers	URL	Date
Airports_Caltrans_2012_2016	point	Caltrans	213 (count)	h_x0001_://www.dot.ca.gov/hq/tsip/gis/data/library/Metadata/Airp_military.html/_x0001_x0001_	2012, 2016
Gas_Stations_GOOGLE_2017	point	Google	13,497 (count)	N/A	2017
Oil_fields_DOGGR_1998	polygon	California Department of Conservation, Division of Oil, Gas, and Geothermal Resources	3,570 km ² (1,378 mi ²)	http://www.conservation.ca.gov/dog/pubs_stats/Pages/technical_reports.aspx,	1982,1992,1998
Oil_wells_DOGGR_Mar2018	point	California Department of Conservation, Division of Oil, Gas, and Geothermal Resources	103,569 (count)	http://www.conservation.ca.gov/dog/maps/Pages/GISMapping2.aspx	2018
Pipelines_NPMS_2017	polyline	PHMSA	11,819 km (7344 mi)	Restricted	2017
Ports_Docks_CA_USDOT_2017	point	USDOT	213 (count)	http://osav-usdot.opendata.arcgis.com/datasets?keyword=Water	2017
Railways_BA_2016	polyline	ESRI	7,446 km (4,627 mi)	Business Analyst - Muir	2016
Refineries_2017	point	EIA, CEC, Refineries websites	18 (count)	multisource	2016-2017
Refineries_parcel	polygon	Refineries_2017 layer and OpenStreet Map	5,068 ha (12,523 acres)	multisource	2017
Roadways_Caltrans_2016	polyline	Caltrans	24,087 km (14,966 mi)	http://www.dot.ca.gov/hq/tsip/gis/data/library/Metadata/Trknet.html	2016
Terminals_2017	point	EIA 2016, EIA 2014, Excise Summary Terminal Activity Reporting System 2016-2017; Kinder Morgan website, Caltrans 2013	111 (count)	multisource	2013-2017
Terminals_parcel	polygon	Tax Parcels from 19 counties with terminals	11,519 ha (28,264 acres)	multisource	2017
Waterways_DOT_2017	polyline	USDOT	30,960 km (19,231 mi)	http://osav-usdot.opendata.arcgis.com/datasets?keyword=Water	2017

A.3 TFS Network Model and Flooding Exposure in the San Francisco Bay Area

This section is a description of 1) the purpose of creating a network model for the TFS; 2) the process to create one interconnected, multi-modal TFS network using data layers collected for the purpose of this research; 3) the calculation of network centrality based on graph theory metrics and 4) an example of routing simulations between critical TFS assets across various flood inundation scenarios. The network model presented below is an exercise focused on the TFS located in the San Francisco Bay Area as it has high concentration of TFS assets and high percentage of average flood inundation across all climate scenarios.

A.3.1 Introduction

There is increasing recognition of the need to assess consequences and identify priority risk-based solutions to increase the resilience of California's Transportation Fuel Sector. This infrastructure sector is highly interconnected as a network both functionally and physically and has been under increasing stress from a number of factors, including aging and deteriorating systems and assets located in areas with growing population density and/or collocated with other infrastructure assets. In the context of global and regional climate change, further concerns include the increasing potential for impacts to infrastructure from extreme weather events such as flooding and wildfire. Sea-level rise (SLR), inland flooding, drought, and fire storms are expected to exacerbate these concerns over time and are of particular importance for both coastal and inland locations which may be densely populated, and which may house critical assets.

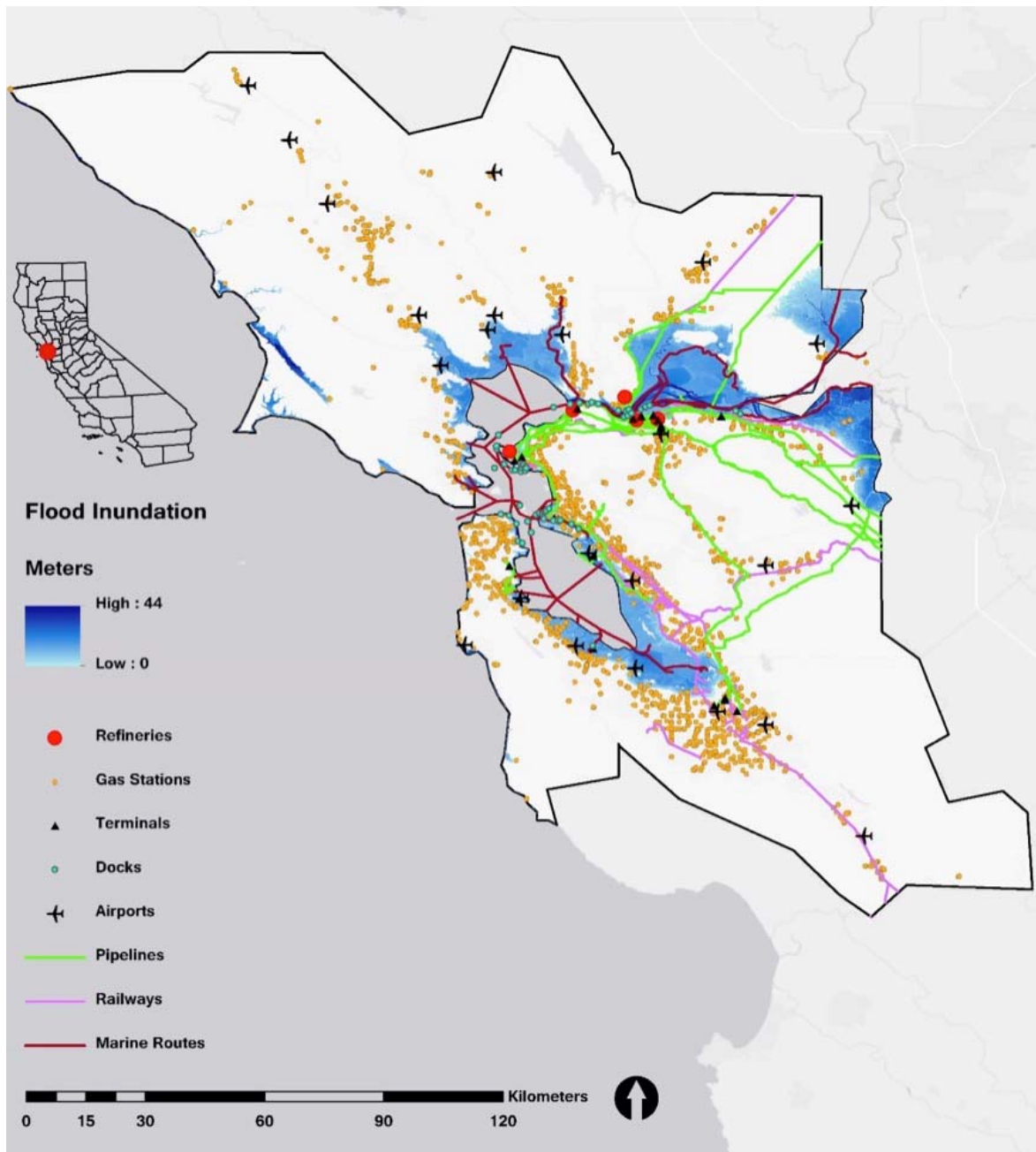

Figure A 1. Flood inundation extent overlapped on TFS assets in the San Francisco Bay area

A.3.1.1 Goal

The purpose of creating a network model for the Transportation Fuel Sector infrastructure in the San Francisco Bay Area is to assess the vulnerability of the TFS as a whole to potential extreme weather hazards. Utilizing GIS, the various physical assets that comprise the transportation fuel supply and distribution chain can be mapped onto the landscape, and specific locations can be identified where these assets may coincide with potential extreme

weather hazards. While this initial step of mapping asset locations helps identify which assets may be directly vulnerable to weather events, it does not allow for measurement of asset network criticality or identification of the indirect effects a weather event may have on the flow between two nodes within the TFS. Since the TFS is highly interconnected both functionally and physically, a data model capable of representing this connectivity is required in order to deeply analyze the impacts of potential extreme weather events such as flooding and wildfire on the sector. Geospatial network modeling facilitates this type of analysis, providing the capacity to identify critical assets within the network, test multiple scenarios of disruptions and measure their outcomes. This will help us better understand the sector from a holistic point of view.

A.3.1.2 Literature Review

Transportation network modeling under disruptions caused by extreme weather events is a growing field of study. The increase in natural disasters in the last few decades and the strong interconnected nature of transportation infrastructure networks have increased the need for transportation network modeling and resiliency studies.

One of the main research fields in transportation resiliency analysis focuses on the resiliency of multimodal networks. Witnessing the adverse impact of abrupt interruptions on the transportation network and their impact on the supply chain, an increasing number of studies have been devoted to addressing disruptions and to improving the supply chain's robustness and resilience (Christopher & Lee, 2004; Ponomarov & Holcomb, 2009; Trkman & McCormack, 2009) In terms of overall framework, Rosenkrantz, Goel, Ravi, & Gangolly (2005) proposed the concept of a "Structure-Based Resilience Matrix" to quantify the resilience of nodes and links in networks. In addition, Ash & Newth (2007) recommend an evolutionary algorithm to optimize network design for better resilience. When it comes to more specific strategies and methodologies, there have been various researchers who published specific papers in understanding network disruptions and resiliency improvement such as agile distribution (Collin & Lorenzin, 2006), quick responsiveness (Klibi, Martel, & Guitouni, 2010), flexibility or redundancy (Naim, Potter, Mason, & Bateman, 2006; Yu, Tang, & Niederhoff, 2011), collaboration, operational integration, and supply chain re-engineering.

A.3.2 TFS Network Modeling Process

A.3.2.1 Definition of a Network

Networks can be represented and understood in various ways. By nature, networks can be defined using graphs, which are mathematical structures used to model pairwise relationships between different elements. They consist of a set of nodes (or vertices) V and corresponding links (or edges) E that connect pairs of vertices. A graph $G = (V, E)$ may be defined either undirected or directed with respect to how the edges connect one vertex to another. In general, graphs can be utilized to represent and analyze many types of relationships and processes in physical, biological, social and information systems. Emphasizing their application to real-world systems, the term network is sometimes defined to mean a graph in which attributes (e.g. names, operators, ownerships etc.) are associated with the nodes and/or edges.

A.3.2.2 TFS as a Network

Continuing from the network model concept described earlier, the various physical TFS assets can be grouped into two essential categories, links and nodes (**Figure A 2**). Links represent the different modes of transporting product along the network, such as maritime, railway, pipelines and roads (**Figure A 3**). While nodes represent specific locations where fuel products can

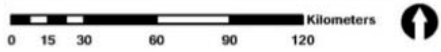
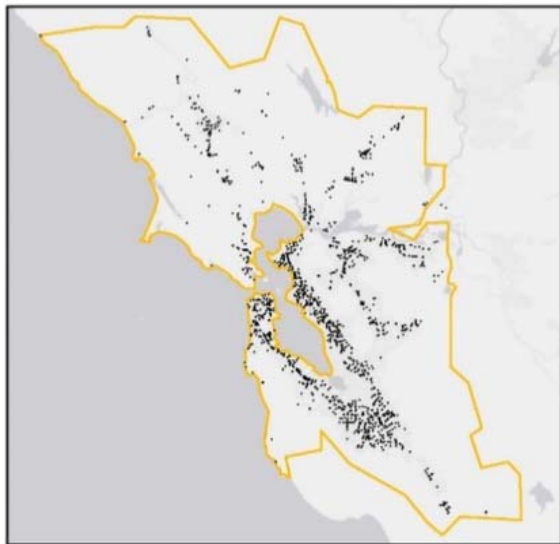

- Gas Station
- Bay Area Boundary

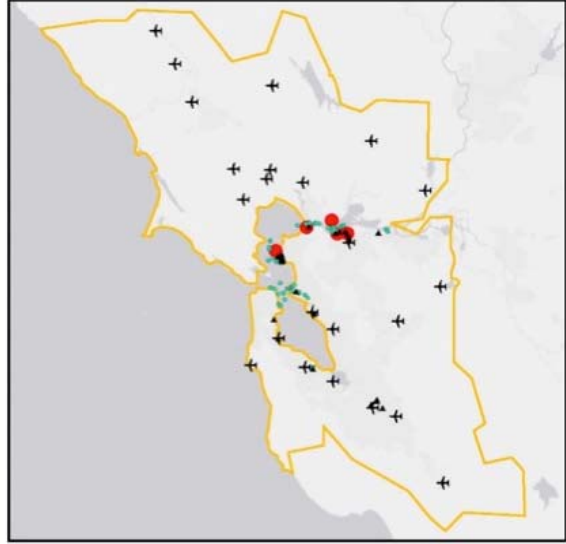

- ▲ Terminal
- Dock
- ✚ Airport
- Refinery
- Bay Area Boundary

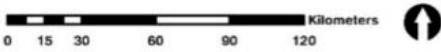
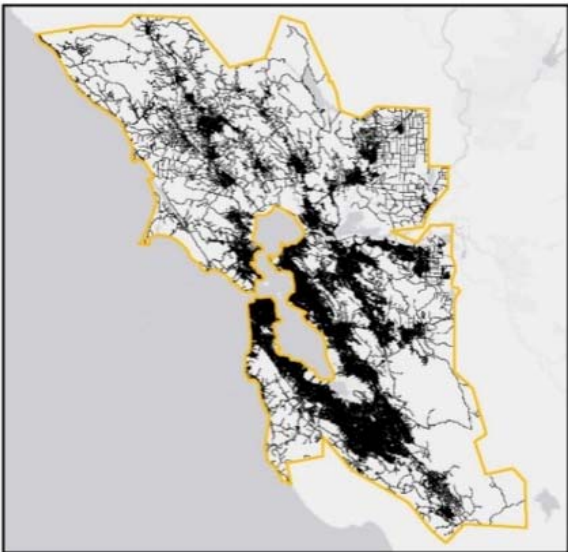

- Roads
- Bay Area Boundary

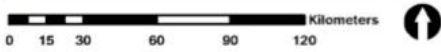
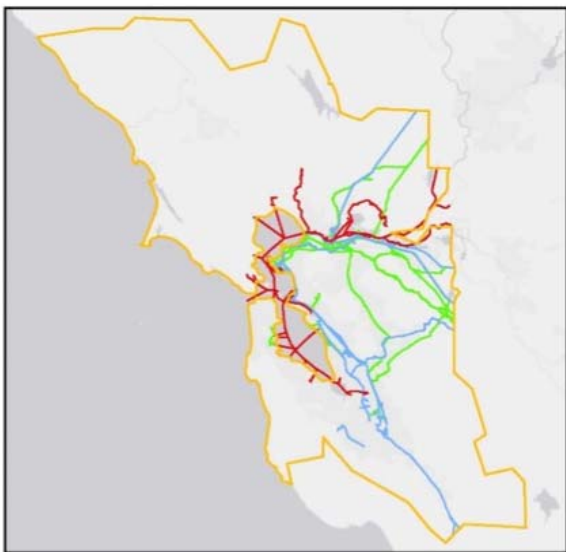

- Marine Route
- Railway
- Pipeline
- Bay Area Boundary

Figure A 3. Illustration of data collected for different types of TFS assets in the San Francisco Bay Area

A.3.3 TFS Network Flooding Exposure Analysis

The analysis framework for this network model is illustrated in the flow diagram below and can be further divided into three steps: the first step is to collect data from public and private sources for all types of TFS assets within the state in order to build them into a comprehensive multimodal network. The process of data collection has been discussed in the first part of Appendix A. Building on this, all types of node and link data are integrated together into a comprehensive multimodal network using NetworkX, a Python language software package for the creation, manipulation, and study of the structure, dynamics, and function of complex networks (Hagberg et al., 2008). Knowledge about the connectivity across different types of assets (see Chapter 2) was utilized in the creation of this multimodal network. The second step is to calculate centrality using metrics from Graph Theory for all types of nodes within the network to identify critical TFS assets in terms of topological connectivity. These nodes are later classified into five different classes based on quantile classification of their centralities. The calculation results are integrated with findings from the stakeholder discussions. From this we identify potential critical origin and destination nodes to do network routing simulations under different hazard scenarios in the final step.

The first 48 out of 120 coastal flooding scenarios, which cover all near-term climate scenarios from 2000 to 2040, are considered in the network model. In this process, 48 different networks are created respectively based on 48 coastal flooding conditions. Routing simulations between 2 selected origin-destination examples from step two are conducted to demonstrate the impact of coastal flooding on TFS infrastructure network.

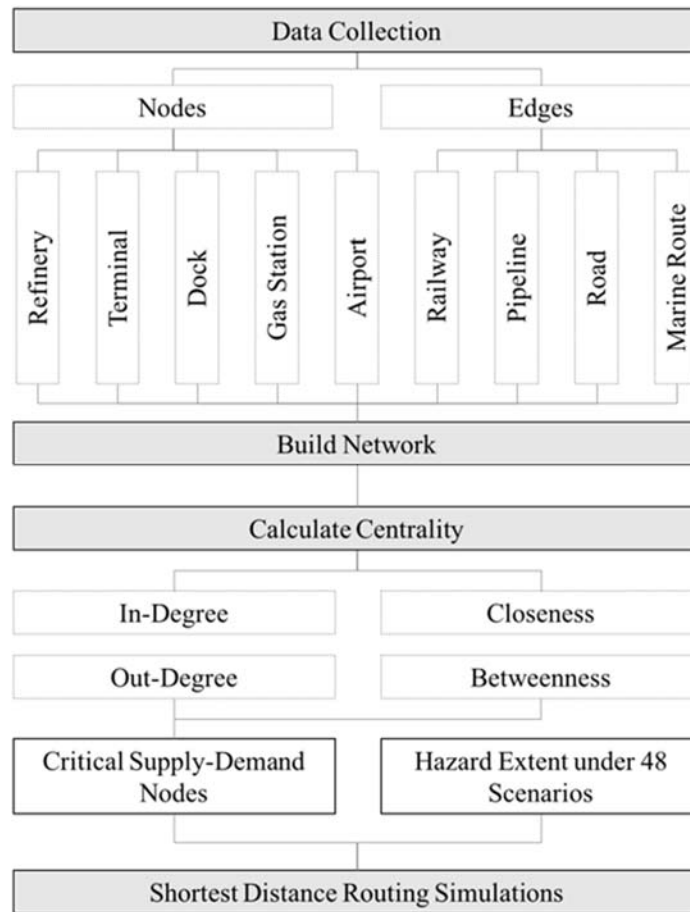

Figure A 4. Diagram of method conceptual framework

A.3.3.1 Centrality Calculation

In graph theory and network analysis, centrality describes how important a node is within a given network. Different types of centrality metrics characterize the importance of a node based on different criteria. In this section, we use five centrality metrics and apply them on the TFS network. Below is a detailed description of those five centrality metrics.

A.3.3.2 Degree Centrality

In the network model, degree centrality describes the number of links a given node is connected to. Nodes with higher degree centrality suggest that they are connected with many other nodes through links. In the case of the TFS network, nodes such as refineries and terminals have higher degree centrality in that they are usually connected to multiple types of links like pipelines, railways, waterways etc. However, degree centrality alone cannot fully describe how critical a node is in terms of topological connectivity, other types of centrality such as in-degree, out-degree, betweenness and closeness centrality can contribute to a better understanding.

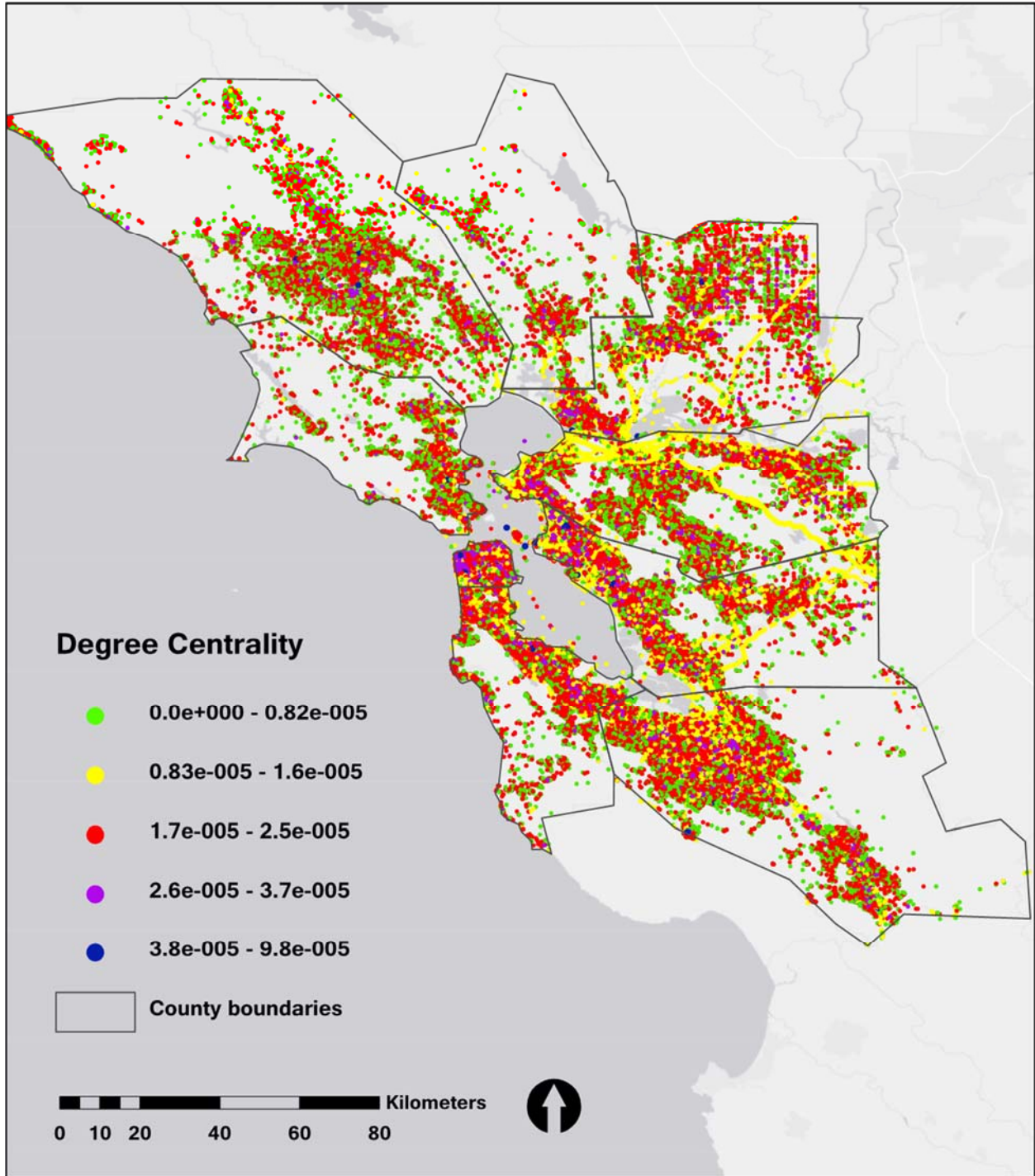

Figure A 5. Map of degree centrality in San Francisco Bay area

A.3.3.3 In-degree Centrality

In-degree centrality of a node measures how many links is going from other nodes to this node. Since all links within the TFS network have directions, i.e. each link connects a 'from node' and a 'to node', we are able to calculate how many links does a node connect to that treats this node as a 'to node' instead of a 'from node'. In-degree centrality is a metric that helps identify critical

destination nodes within the network model. The result is classified into five different classes using quantile classification and nodes with high in-degree centrality are selected as potential destination nodes for routing simulation.

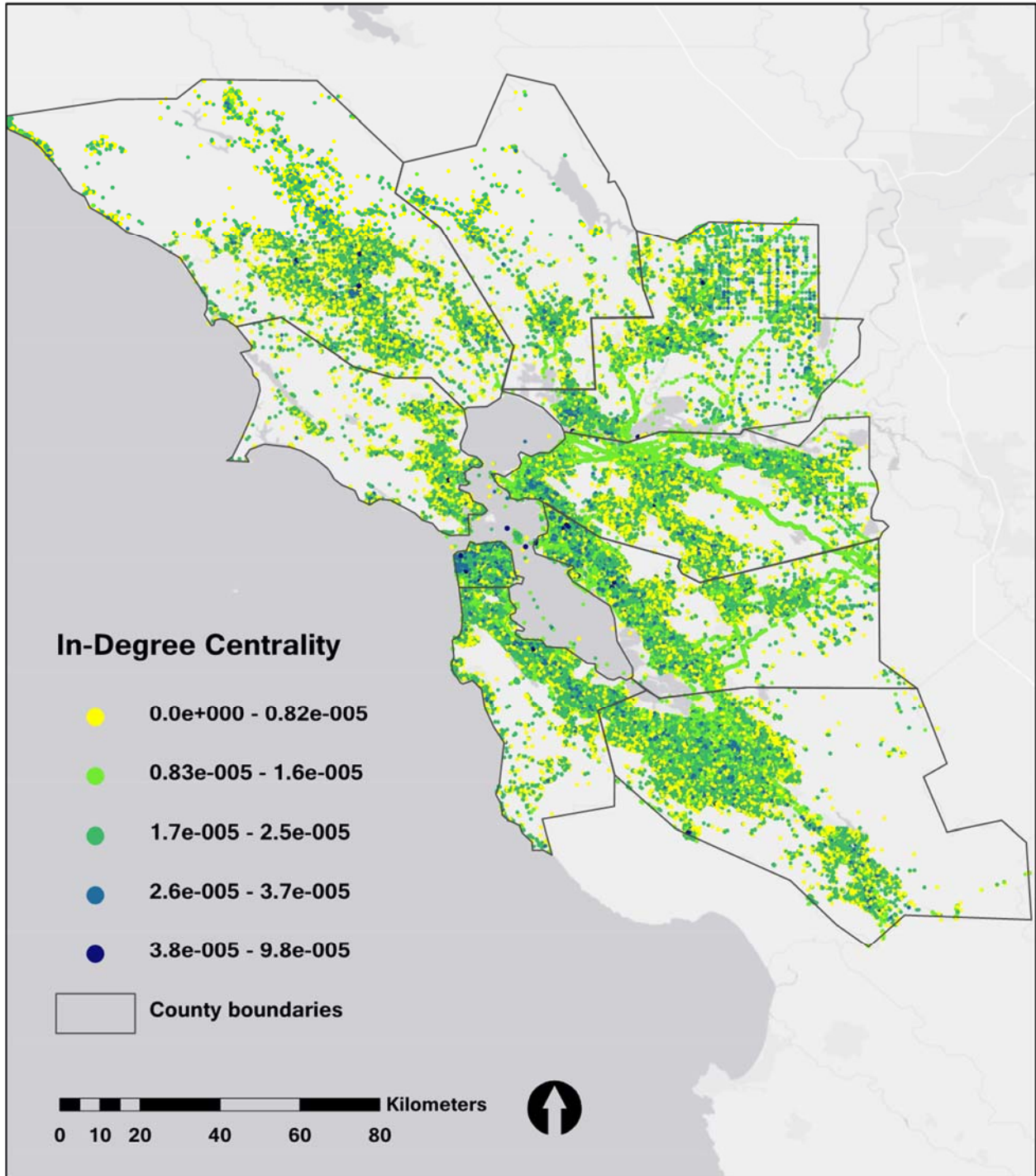

Figure A 6. Map of in-degree centrality in San Francisco Bay area

A.3.3.4 Out-degree Centrality

Similar to in-degree centrality, out-degree centrality measures how many links is going from the node to other nodes. For a particular node within the network, we measure how many times does a node act as a source node, i.e. how many links does a node connect to that treats this node as a 'from node' instead of a 'to node'. This metric is helpful in understanding critical origins within the network for later routing simulations. Quantile classification is also applied to the results of this analysis and the top tier nodes with high out-degree centrality are filtered out as potential origin nodes for routing simulation.

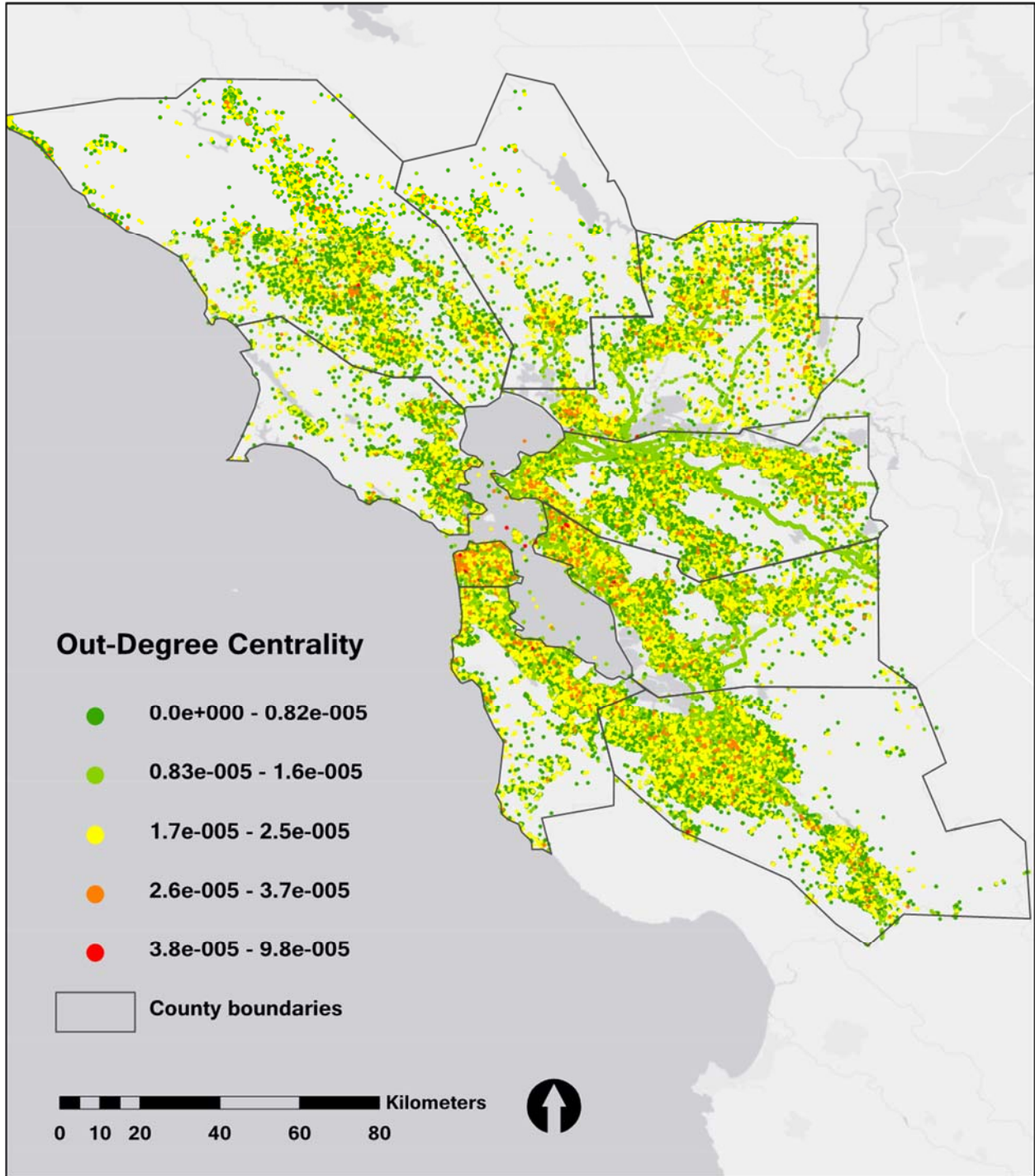

Figure A 7. Map of out-degree centrality in San Francisco Bay area

A.3.3.5 Betweenness Centrality

This metric measure how many times a node acts as a 'bridge' between the shortest path from one node to another based on the network connectivity. To calculate betweenness centrality, we first start with a fully connected network and generate shortest distance routes between all

possible pairs of nodes. We store the names of all intermediate nodes and count how many times a particular node appears. If a node appears many times, then this means that this node is on many shortest distance routes. If this node is removed out of the network (similar to an asset being disrupted due to coastal flooding), then many shortest distance routes within the network will need to be re-routed which might lead to increased cost in time and resource. The analysis results show that a majority of refineries and terminals near the Richmond area have high betweenness centrality in the San Francisco Bay Area. Therefore, in the last step, nodes with high betweenness centrality are chosen as potential origins and destinations for routing simulations under 48 flooding scenarios.

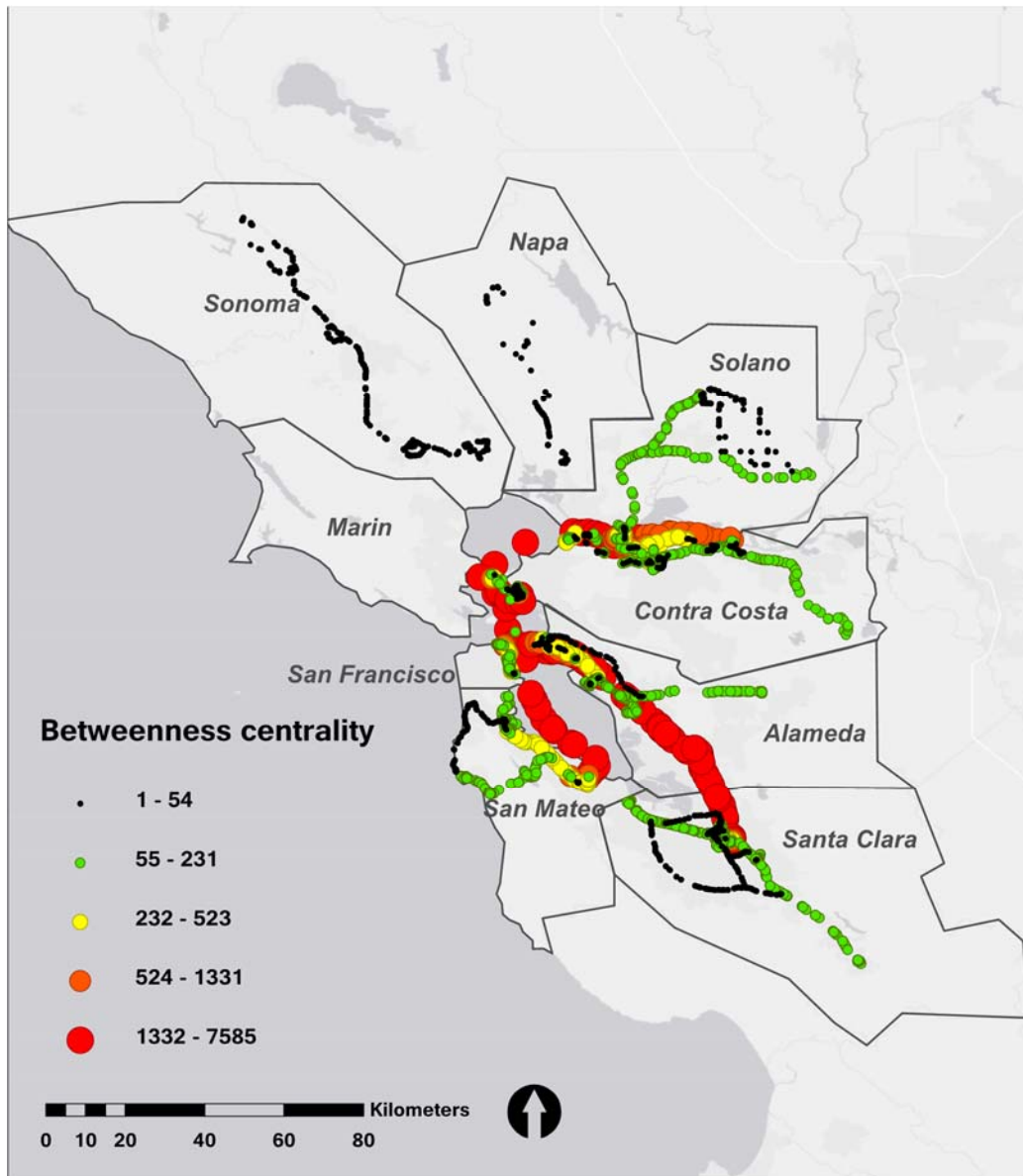

Figure A 8. Map of betweenness centrality in San Francisco Bay area

A.3.3.6 Closeness Centrality

Closeness centrality measures the sum of distances from one node to all other nodes. This metric reflects how far it takes to spread resources within the network and the node's capacity to influence all other nodes in the network. However, the results from this calculation show that many gas stations in Sonoma County have high closeness centrality, which contradicts our expectations because these nodes are situated at the 'edge' of the network and therefore are expected to have small closeness centrality. This contradiction shows that graph theory metrics alone cannot fully explain the criticality of nodes within the network. This is why we incorporated domain knowledge and information gathered from stakeholder engagement in the final step to point to where the critical origins and destinations within the TFS network are located.

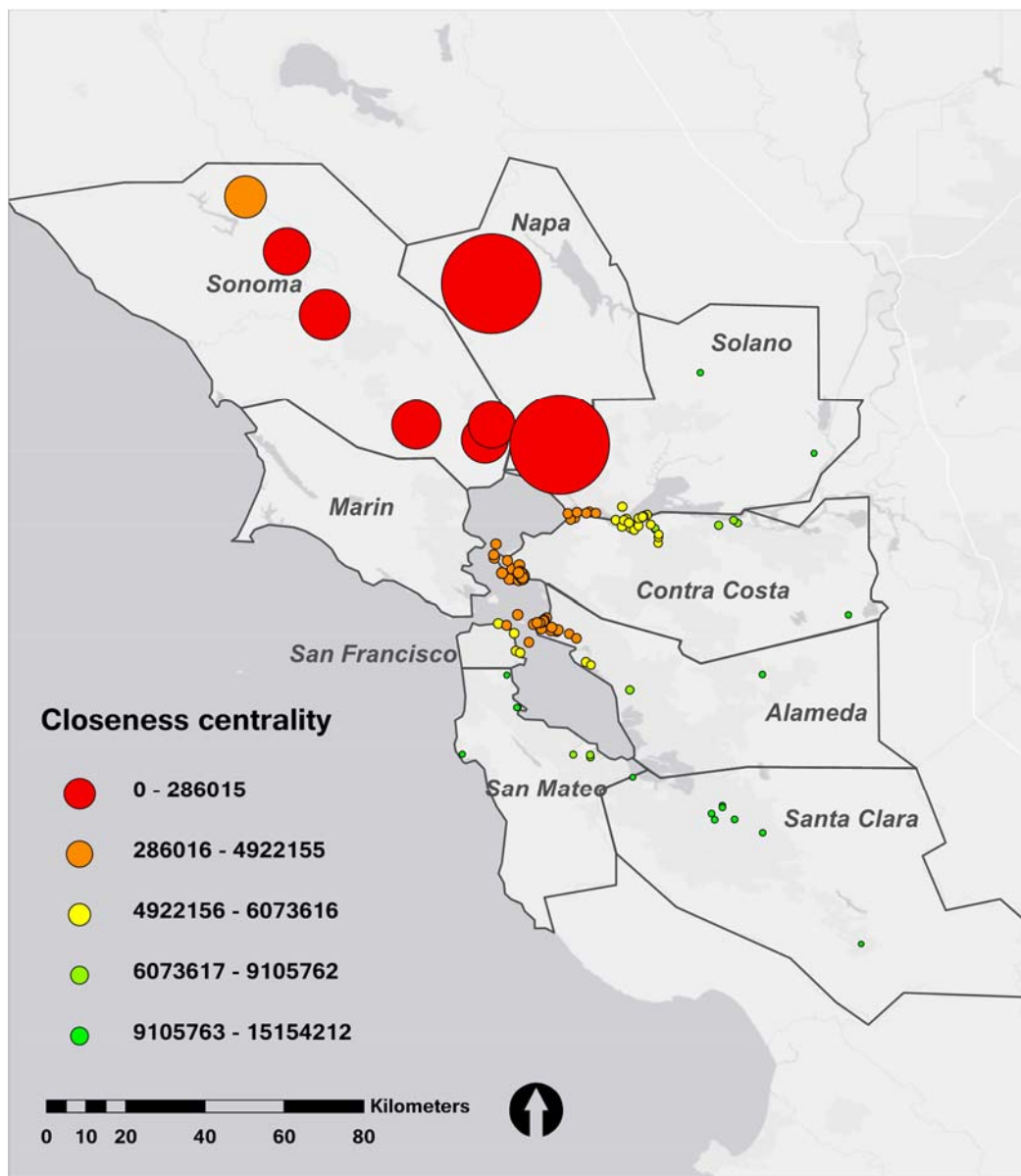

Figure A 9. Map of closeness centrality in San Francisco Bay area

A.3.3.7 Routing Simulation

The final step is to understand the impact of coastal flooding on the TFS by running routing simulations within the network. As is mentioned previously, only 48 scenarios are being considered in this analysis. A total of 48 different networks are created by overlaying different flood rasters on top of nodes and links within the network. Nodes that lie within a raster cell (50 by 50 m; 164 by 164 ft) with a value of more than 1 (water depth in meters) are removed from the network. The six subplots below are histograms of the percentage inundation for different types of nodes over 48 scenarios. Results show that on average 62% of the docks are being inundated across all 48 scenarios, 50% of the gas stations are subject to coastal flood damage. In addition, based on summary statistics, it can be concluded that over 48 scenarios (2000-2040), the impact of coastal flooding on the TFS network in terms of average percentage asset damage has little variation.

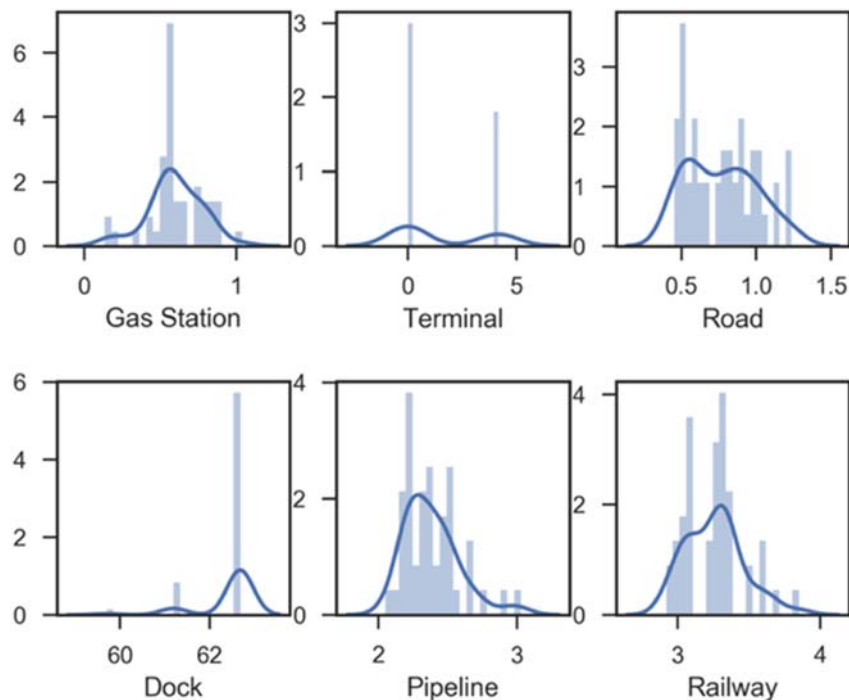

Figure A 10. Diagrams of percentage inundation of nodes by type

One pair of nodes is illustrated here as an example to show the impact of coastal flooding on the petroleum fuel flow from the Chevron Martinez terminal to the Phillips 66 Richmond terminal. On the right is the “new” potential route due to coastal flooding which has mainly flooded the last leg of the route near Richmond. The model indicates that an alternative route could be used to deliver petroleum product first to a marine terminal and then to the destination via an extra marine route. This would mean that, in the future, there could be extra desire to use an already busy marine terminal for oil product transfer. In addition, it would mean that waterways that

are not now being utilized will need to be utilized in future emergency scenarios to successfully complete the oil product transport to the Phillips 66 terminal.

When we run routing simulations between these two nodes across 48 scenarios (2000 - 2040), the results show that over 40 runs generated the same alternative route (in red). This suggests that although the flooding scenarios are different, the impact on the flow between these nodes can be very similar. This also coincides with the summary statistics of average inundation percentage of all types of nodes across 48 scenarios.

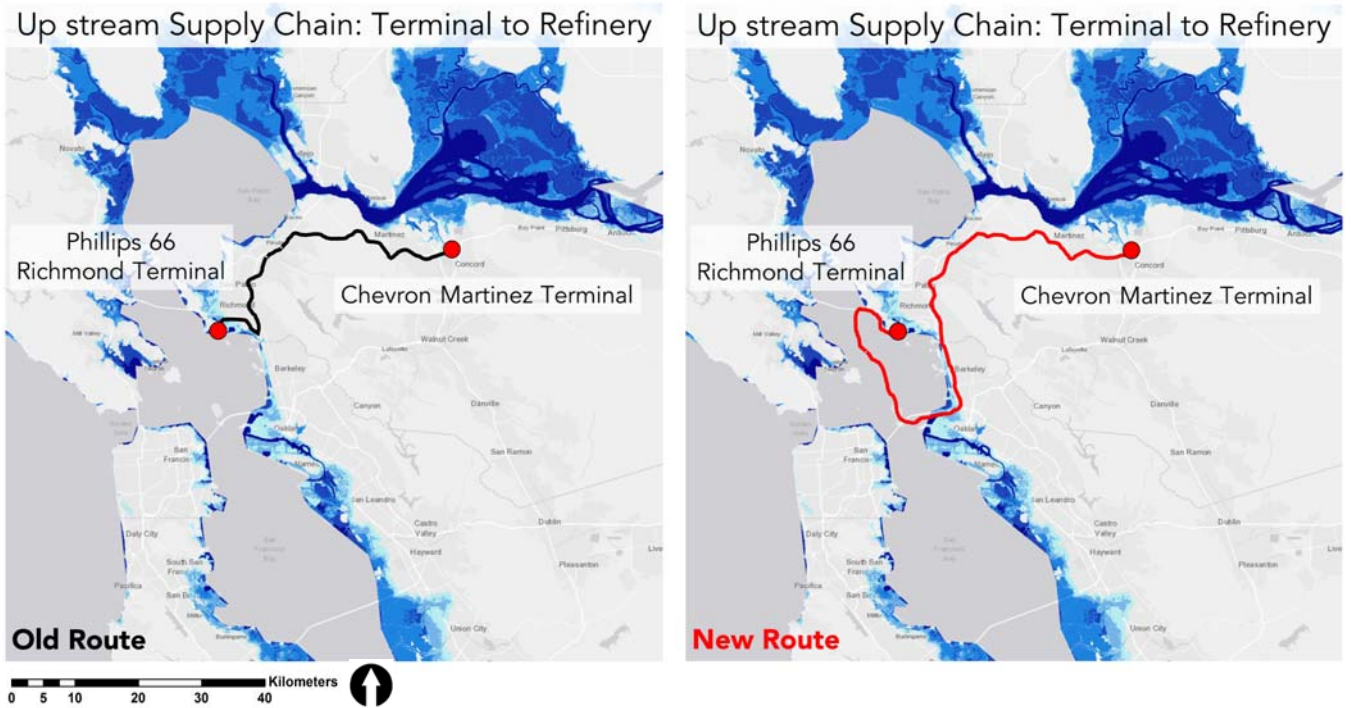

Figure A 11. Routing simulation before-after illustrations

A.4 References

- Alon USA. (2017). California Refineries. Retrieved from <http://www.alonusa.com/refining/california-refineries>
- Ash, J., & Newth, D. (2007). Optimizing complex networks for resilience against cascading failure. *Physica A: Statistical Mechanics and Its Applications*, 380, 673–683. <https://doi.org/10.1016/j.physa.2006.12.058>
- California Department of Transportation. (2012). *California Military Use Airports*. Retrieved from http://www.dot.ca.gov/hq/tsip/gis/datalibrary/Metadata/Airp_military.html
- California Department of Transportation. (2016a). *California Public Use Airports*. Retrieved from <http://www.dot.ca.gov/hq/tsip/gis/datalibrary/Metadata/Airports.html>
- California Department of Transportation. (2016b). *Truck Network (2016)*. Retrieved from <http://www.dot.ca.gov/hq/tsip/gis/datalibrary/Metadata/Trknet.html>
- California Energy Commission. (2016). California Oil Refinery History. Retrieved from http://www.energy.ca.gov/almanac/petroleum_data/refinery_history.html
- California Energy Commission. (2017). California's Oil Refineries. Retrieved from http://www.energy.ca.gov/almanac/petroleum_data/refineries.html
- Christopher, M., & Lee, H. (2004). Mitigating supply chain risk through improved confidence. *International Journal of Physical Distribution & Logistics Management*, 34(5), 388–396. <https://doi.org/10.1108/09600030410545436>
- Collin, J., & Lorenzin, D. (2006). Plan for supply chain agility at Nokia: Lessons from the mobile infrastructure industry. *International Journal of Physical Distribution & Logistics Management*, 36(6), 418–430. <https://doi.org/10.1108/09600030610677375>
- Division of Oil, Gas, and Geothermal Resources. (2017). *California Oil and Gas Fields* (No. TR10-12). California Department of Conservation. Retrieved from http://www.conservation.ca.gov/dog/pubs_stats/Pages/technical_reports.aspx
- Division of Oil, Gas, and Geothermal Resources. (2018). *All Wells.Shp*. GIS Mapping. California, 2018. Retrieved from <http://www.conservation.ca.gov/dog/maps/Pages/GISMapping2.aspx>.
- Hagberg, A. A., Schult, D. A., & Swart, P. J. (2008). Exploring network structure, dynamics, and function using NetworkX. In *Proceedings of the 7th Python in Science Conference*, (Pasadena, CA USA), 11–15.
- Kinder Morgan, Inc. (2017). Concord Station. Retrieved from https://www.kindermorgan.com/pages/business/products_pipelines/concord.aspx
- Klibi, W., Martel, A., & Guitouni, A. (2010). The design of robust value-creating supply chain networks: A critical review. *European Journal of Operational Research*, 203(2), 283–293. <https://doi.org/10.1016/j.ejor.2009.06.011>

- Naim, M. M., Potter, A. T., Mason, R. J., & Bateman, N. (2006). The role of transport flexibility in logistics provision. *The International Journal of Logistics Management*, 17(3), 297–311. <https://doi.org/10.1108/09574090610717491>
- Phillips 66. (2018). Refining. Retrieved from <http://www.phillips66.com/refining>
- Pipeline and Hazardous Materials Safety Administration. (2017). National Pipeline Mapping System. Retrieved from <https://www.npms.phmsa.dot.gov/GeneralPublic.aspx>
- Ponomarov, S. Y., & Holcomb, M. C. (2009). Understanding the concept of supply chain resilience. *The International Journal of Logistics Management*, 20(1), 124–143. <https://doi.org/10.1108/09574090910954873>
- Rodriguez, J.-P., Comtois, C., & Slack, B. (2017). *The Geography of Transport Systems* (4th ed.). Routledge.
- Rosenkrantz, D. J., Goel, S., Ravi, S. S., & Gangolly, J. (2005). *Structure-Based Resilience Metrics for Service-Oriented Networks*. In M. Dal Cin, M. Kaâniche, & A. Pataricza (Eds.), *Dependable Computing - EDCC 5* (Vol. 3463, pp. 345–362). Berlin, Heidelberg: Springer Berlin Heidelberg. https://doi.org/10.1007/11408901_26
- Trkman, P., & McCormack, K. (2009). Supply chain risk in turbulent environments – A conceptual model for managing supply chain network risk. *International Journal of Production Economics*, 119(2), 247–258. <https://doi.org/10.1016/j.ijpe.2009.03.002>
- U.S. Department of Transportation. (2017). *Geospatial at the Bureau of Transportation Statistics*. Retrieved from <http://osav-usdot.opendata.arcgis.com/datasets?keyword=Water>
- U.S. Energy Information Administration. (2017). Layer Information for Interactive State Maps. Retrieved from https://www.eia.gov/maps/layer_info-m.php
- Yu, D. Z., Tang, S. Y., & Niederhoff, J. (2011). On the benefits of operational flexibility in a distribution network with transshipment. *Omega*, 39(3), 350–361. <https://doi.org/10.1016/j.omega.2010.08.004>

APPENDIX B: SELECTION OF SCENARIOS, SITES, AND ANALYSIS PERIODS

B.1 Deriving Estimates of Future Conditions

We obtained various climate and hazard projections from the Fourth Assessment to estimate the exposure and vulnerability of TFS to extreme weather events into the future. These climate and hazard projections were derived based on a range of Representative Concentration Pathways (RCPs), General Circulation Models (GCMs), probabilistic sea level rise (SLR) projections, and changes in Land Use and Land Cover (LULC). The combination of these components formed the scenarios used in this study. This section is intended to explain the components forming the scenarios in this study.

B.1.1 Climate Projections Based on RCPs and GCMs

This study's climate projections, such as precipitation and temperature, are produced globally through RCPs and GCMs. RCPs are scenarios of future climate, which provide inputs for climate models (e.g. GCMs) that generate a range of weather variables such as precipitation and temperature. While there exist four RCPs and many GCMs, the Fourth Assessment recommends research groups use data from four priority GCMs (i.e. CanESM2, CNRM-CM5, HadGEM2, and MIROC5).

RCPs, or representative concentration pathways, are spatially and temporally explicit representations of a broad range of possible future climate scenarios (Bjørnæs, 2013; Moss et al., 2010). The RCPs are the newest set of scenarios used in the Intergovernmental Panel on Climate Change (IPCC) 5th Assessment (Moss et al., 2008), replacing the scenarios in previous IPCC assessments. Scenarios are sound descriptions about how future will be in terms of socioeconomy, technology, greenhouse gases (GHG) emissions, and climate. Scenarios are not to predict the exact future, but to show a wide range of possible futures (Moss et al., 2010). Four types of RCPs, namely RCP 2.6, RCP 4.5, RCP 6.0, and RCP 8.5 (**Table B 1**) were selected through several expert meetings to represent scenarios developed after the IPCC 4th Assessment (Moss et al., 2010). These four RCPs together cover a broad spectrum of GHG concentration and radiative forcing (i.e. additional energy taken up by the Earth due to the greenhouse effect) affecting global mean temperature (Bjørnæs, 2013) reported by the scenarios (**Figure B 1**). For every RCP, a modeling group further developed related data products that were spatially and temporally explicit, providing information such as emission and concentration of greenhouse gases, air pollution, and LULC change (Vuuren et al., 2011). These data products are used as inputs for climate modeling.

A given RCP could be achieved through different socioeconomic and policy interventions (Bjørnæs, 2013; Moss et al., 2010), as different interventions could lead to the same radiative forcing characterizing a RCP. Here we list some assumptions underlying each RCP to show how its future will be like. RCP 8.5 is with high GHG emissions compared to the scenario literature. This RCP generally assumes high population, slow income growth, along with modest improvements in technological change and energy intensity, resulting in high energy demand and GHG emissions under no climate change policies (Riahi et al., 2011). RCP 6 is a climate-policy intervention scenario with intermediate emissions. This RCP could be realized with heavy reliance on fossil fuels, intermediate energy intensity, increased use of croplands

and decreased use of grasslands, stable methane emissions (Bjørnæs, 2013; Masui et al., 2011). RCP 4.5 requires energy systems to shift to electricity and lower emission technologies, and to implement carbon capture and geological storage (Thomson et al., 2011). This RCP also assumes strong reforestation, decreases in croplands and grasslands, and strict climate policies (Bjørnæs, 2013). RCP 2.6 is at the low end of GHG emissions reported in the scenario literature. This RCP represents the scenarios aiming to limit the increase of global mean temperature to 2°C. Achieving such goal requires substantial changes in energy use and emissions of non-CO₂ gases (Vuuren et al., 2011).

Table B 1. The four RCPs (adapted from Moss et al., 2008)

Name	Radiative forcing	Concentration¹	Pathway
RCP 8.5	>8.5Wm ⁻² in 2100	> ~1370 CO ₂ -eq in 2100	Rising
RCP 6.0	~6Wm ⁻² at stabilization after 2100	~850 CO ₂ -eq (at stabilization after 2100)	Stabilization without overshoot
RCP 4.5	~4.5Wm ⁻² at stabilization after 2100	~650 CO ₂ -eq (at stabilization after 2100)	Stabilization without overshoot
RCP 2.6	Peak at ~3Wm ⁻² before 2100 and then declines	peak at ~490 CO ₂ -eq before 2100 and then decline	Peak and decline

¹ Approximate CO₂ equivalent (CO₂-eq) concentrations, which is a simple transformation from radiative forcing.

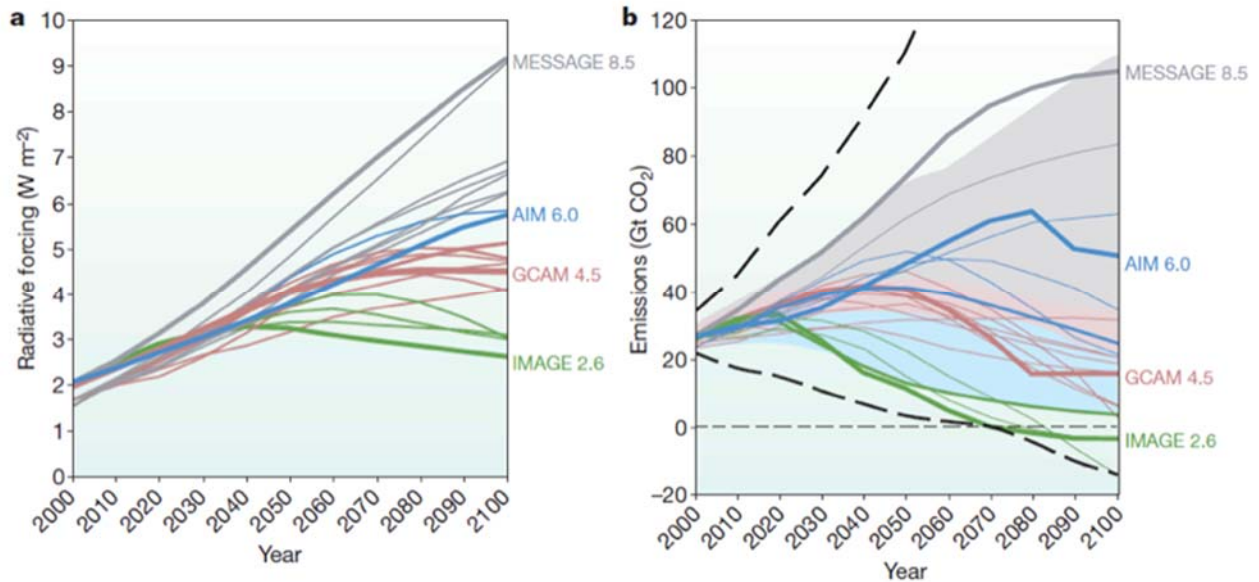

Figure B 1. Representative concentration pathways (Source Moss et al., 2010). a, changes in radiative forcing relative to pre-industrial conditions. Bold colored lines show the four RCPs; thin lines show individual scenarios represented by their respective RCPs. b, energy and industry CO₂ emissions. The range of emissions in scenarios after IPCC 4th Assessment is shown for the maximum and minimum (thick dashed curve) and 10th to 90th percentile (shaded area). Blue shaded area is for mitigation scenarios; grey shaded area is for reference scenarios; pink area is the overlap between mitigation and reference scenarios. MESSAGE 8.5: the model for RCP 8.5 data products, AIM 6.0: the model for RCP 6.0 data products, GCAM: the model for RCP 4.5 products, IMAGE 2.6: the model for RCP 2.6 products.

Four GCMs, namely, CanESM2, CNRM-CM5, HadGEM2, and MIROC5 were recommended by the Fourth Assessment as priority models to obtain climate projections under RCP 4.5 and 8.5. The four priority GCMs were selected from the GMIP5 archive (i.e. Climate Model Intercomparison Projection, version 5, a collection of most recent GCMs), through a three-step screening process developed by (DWR & CCTAG, 2015) and consensus reached by the Climate Action Team Research Working Group (i.e. the steering committee for the Fourth Assessment). The three-step screening process evaluates a GCM's historical performance at the global scale, across the Southwestern United States, and for California's water resource planning (DWR & CCTAG, 2015; D. Pierce et al., 2016). The 32 CMIP5 GCMs providing daily data were selected as the input of this screening process and were reduced to 10 Californian GCMs after the screening. However, the 10 GCMs could still be too much in some cases. Therefore Pierce et al., (2016) applied an additional filter to reduce the 10 GCMs to 4 GCMs representing a 'warm/dry' scenario, a 'average' scenario, a 'cool/wet' scenario, and a 'complementary' scenario (i.e. be most unlike the other three scenarios). This filter used seven metrics to score the GCMs in terms of the climate patterns they generated. The resulting 'warm/dry' GCM tends to simulate higher temperature and less precipitation, which is contrary to the 'cool/wet' GCM. The 'average' GCM tends to give the average climate estimations among the 10 GCMs. The 'complementary' GCM tends to be most unlike the previous three GCMs regarding the seven metrics. Therefore, these four GCMs can have a full spectrum of the 10 Californian model's results. Based on this filtering and consultation with other experts and government agencies, the Fourth Assessment

recommend the following four GCMs as its priorities (**Table B 2**). These GCMs provide daily estimates such as temperature and precipitation.

Table B 2. The four priority GCMs recommended by the Fourth Assessment

Climate pattern	Description	GCM
Warm/dry	Higher temperature and less precipitation	HadGEM2-ES
Cool/wet	Lower temperature and more precipitation	CNRM-CM5
Average	Close to average estimates of the 10 Californian GCMs	CanESM2
Complementary	Most different from the above three GCMs in estimated climate pattern	MIROC5

B.1.2 Bias Correction and Downscaling GCM Projections

Pierce et al., (2016) applied bias correction and downscaling techniques to the GCMs so that the results could be applied to a California-wide analysis. GCMs are meant for global scale estimates of climate, which limits their capabilities to regional level (e.g. California) studies (Pierce et al., 2016). First, GCMs may have bias, such as continuous over/under estimations, in their results for certain geographies around the globe. Second, GCMs’ spatial resolutions are too coarse for regional analysis. Pierce et al., (2016) accounted for the bias issue using a technique called bias correction. Next, they implemented a downscaling procedure, Localize Constructed Analogs (LOCA), to refine bias-corrected GCM results to a 1/16th degree (about 6.2 km) spatial resolution. Their resulting dataset, referred as LOCA in this document, provides a limited set of weather variables such as precipitation, temperature, wind speed, and humidity. Since these variables are limited to meet the needs of some studies, Pierce et al., (2016) used these variables to drive a Variable Infiltration Capacity (VIC) land surface model to obtain additional variables including as rain, runoff, snow cover, soil moisture, etc.

B.1.3 Hourly Sea Level Projections

We obtained hourly sea level projections from Cayan et al. (2016) to model coastal flooding induced by sea level rise and storm surge. The projections are made at nine locations with reliably continuous coastal tide gauge data since before 1984, and provide hourly sea levels that

combinations of long-term SLR and short-term sea level fluctuations under RCP 4.5 and 8.5 and different GCMs (Cayan et al., 2016).

The long-term SLR is projected probabilistically for both RCP 4.5 and 8.5 by Cayan et al. (2016) based on a method of Kopp et al. (2014), with additional SLR contributions from loss of Antarctica ice sheets modeled by DeConto & Pollard (2016). The Kopp et al. (2014) method calculates SLR probabilities using a Latin hyper-cube to sample time-dependent probability distribution of five primary global SLR components including land surface water contributions, contributions from glaciers and ice caps, oceanographic process, and contributions from Greenland ice sheets. Under RCP 8.5, contributions from Antarctica ice sheets projected by DeConto & Pollard (2016) were included as an additional component. After the sampling, 50th percentile, 95th percentile, and 99.9th percentile SLR values under RCP 4.5 and 8.5 respectively were incorporated in the final hourly sea level projections. The short-term sea level fluctuations are resulted from astronomical tides, storm surges, and El Nino Southern Oscillation events (ENSO) (Cayan et al., 2016). Eight selected GCMs, including the four priority models in the Fourth Assessment, were used to provide data for estimating these short-term fluctuations. The short-term fluctuations were then combined with the long-term SLR to obtain the hourly sea level projections.

B.1.4 Land Use and Land Cover Projections

Wildfire futures used in assessments of near and longer wildfire threats posed to TFS asset containing regions included estimates of total area vegetated during each time step evaluated (Westerling, forthcoming). Projections of the vegetated fraction of each area modeled for the 4th Assessment were derived from empirical data, demographic trends, and the outputs of Land Use and Carbon Scenario Simulator (LUCAS) model runs that produced estimates that described how land use and land cover (LULC) conditions were expected to change throughout California and Nevada for the 2001-2100 period (Sleeter et al., 2017). To account for the stochastic nature of land use change in response to population growth over time, 10 Monte Carlo replications of each population growth scenario selected for simulation were run. The LUCAS model runs produced outputs that were based on NLCD land-use/land cover thematic classifications and changes that were likely to occur over time due to these changes (**Figure B 2**). The amounts and types of land cover classification changes expected to take place over the one-hundred-year prediction period were based on historical trends in the rates at which agricultural lands in California have expanded and contracted, the rates of forest harvest have occurred in the state, as well as the process of urbanization that tended to increase the developed fractions of areas modeled.

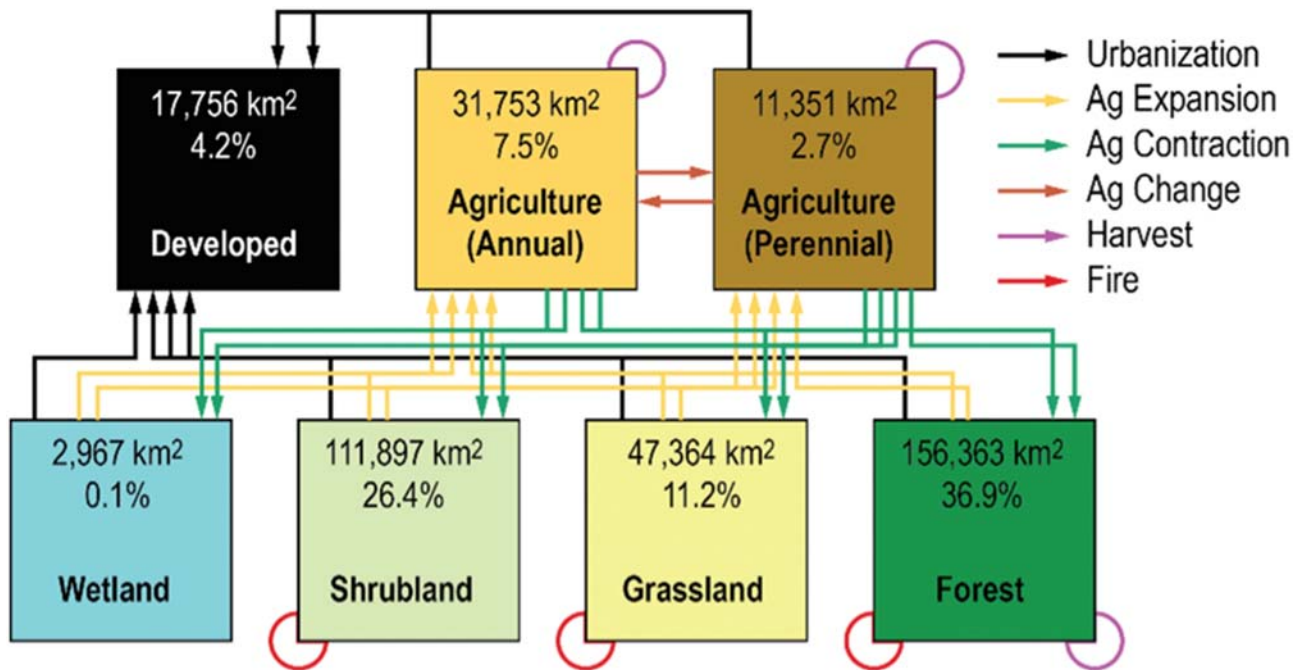

Figure B 2. Example of LUCAS model land use land cover state change pathways and the statewide totals for the NLCD coverage types during the 2001 period in which the models were initiated. Figure reproduced from Sleeter et al. (2017).

Expected rates of urbanization and subsequent future changes in land cover classifications were based on county-scale population growth projections produced by the Demographic Research Unit of the California Department of Finance. The population projections are produced using a variation of the cohort component projection method which incorporated random elements that caused birth and death rates to vary over time, in a probabilistic fashion (Sharygin, 2017). Factors used to determine net migration rates for each cohort had county-level resolutions and the projections of total population changes were based on historical data collected during a period that represented a typical post-demographic-transition society (Lesthaeghe, 2014; Sharygin, 2017). High, central (also referred to as business-as-usual), and low projected demographic change rates were included in the modeling of land cover changes in California and estimates of wildfire futures in the State. In the high growth scenarios, current (2015) birth rates were expected to remain unchanged until the end of the century and life expectancies were predicted to increase throughout most of the state by seven years. Net migration under high population growth scenarios was expected to increase 30% by the end of the period analyzed. Central and low scenarios assumed that total fertility rates declined over the same period while net migration rates decreased by 30% and life expectancy remained either unchanged or increased to a lesser degree than was predicted to occur under the high population growth scenarios (Sleeter et al., 2017).

B.1.5 Defining Scenarios to Model

Since our modeled hazard exposure used the climate, sea level, and LULC projections listed from section B.1.2 to B.1.4, our modeled scenarios were derived based on how these projections were generated. Coastal flooding used the hourly sea level projections by Cayan et al. (2016),

and contained 24 scenarios that were combinations of the two RCPs, four GCMs, and three probabilistic SLR estimates. Inland flooding was driven by rainfall projections from the LOCA-VIC outputs (Pierce et al., 2016), therefore contained eight scenarios produced by the two RCPs and four GCMs. Statewide wildfire exposure by (Westerling, forthcoming) utilized both GCM derived climate projections (Pierce et al., 2016) and LULC projections (Sleeter et al., 2017), therefore contained 240 scenarios by the two RCPs, four GCMs, and three LULC scenarios (each with 10 stochastic variations). The flooding and wildfire scenarios, and how they were generated, are illustrated in **Figure B 3**.

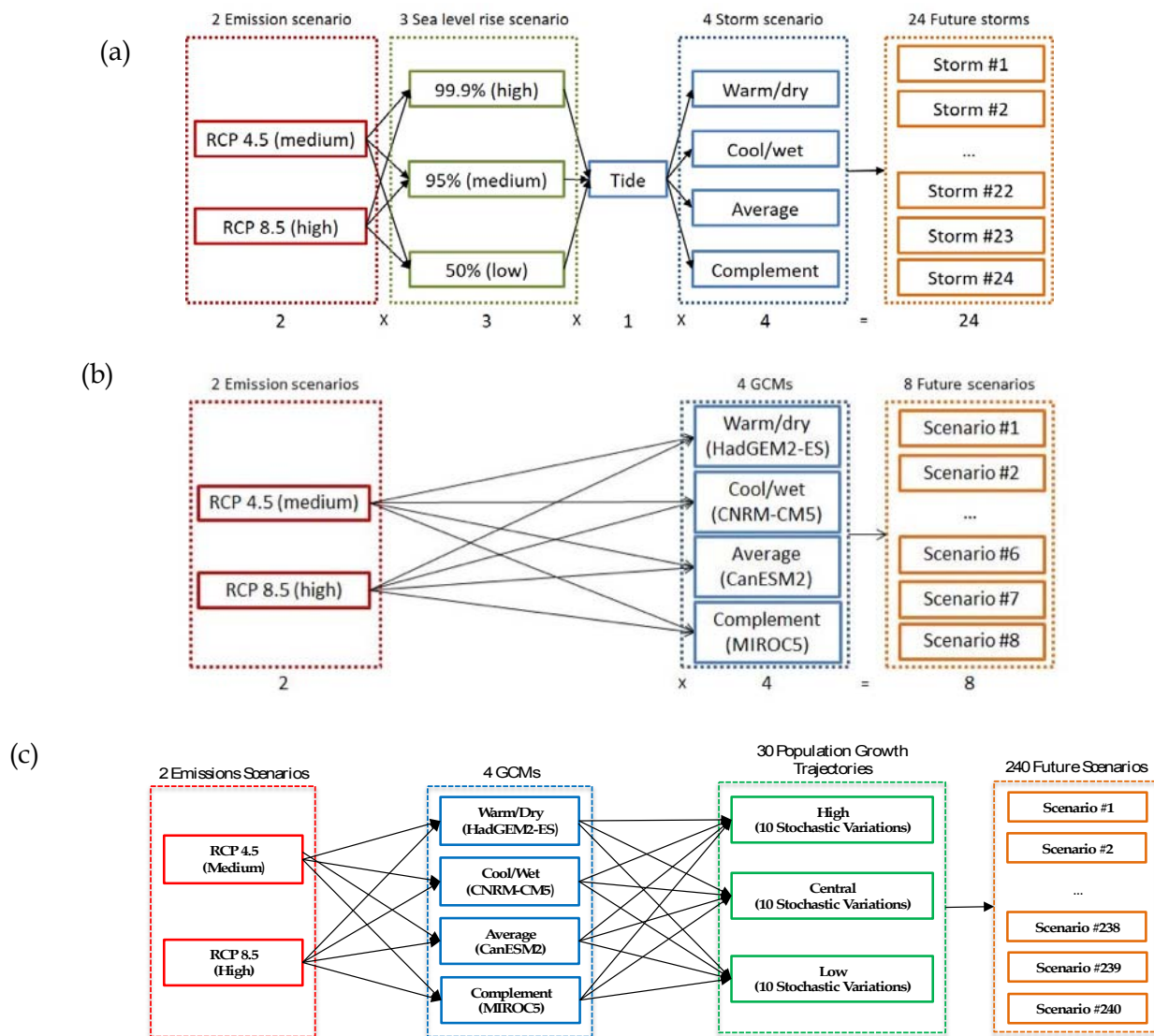

Figure B 3. Scenarios implemented by this study. (a) the 24 coastal flooding scenarios, (b) the eight inland flooding scenarios, (c) the 240 wildfire scenarios.

B.2 Selecting Periods of Analysis

We analyzed flooding and wildfire exposure every 20 years between 2000 and 2100 to fit with different planning and investment circles of TFS stakeholders. All the projections used in our study (i.e. hourly sea level, rainfall intensity, temperature, wildfire exposure) provide hourly to

monthly data from present time to 2100, providing us with the flexibility to select different time periods of analysis to match with TFS stakeholder's needs and to address the longer-term hazard exposure. Given such flexibility, we arbitrarily defined 20-year intervals between 2000 and 2100 (i.e. 2000-2020, 2020-2040, 2040-2060, 2060-2080, 2080-2100) as our periods of analysis for flooding and wildfire models. The 2020-2040 period was recognized by many stakeholders as their near term which drew the most interest. While only few stakeholders involved in discussions were looking beyond 2040, we still included the periods after 2040 to address the long-term exposure to flooding and wildfire.

In addition, near-term assessments of wildfire were also of greater interest to stakeholders than ones further away from the present time. This drove our decision to focus on the current period conditions when modeling wildfire behavior at local scales with fine spatial resolution. While we incorporated long-term trends in wildfire by Westerling (forthcoming) into this study, these trends far out from the present introduced a substantial amount of uncertainty (e.g. changes in fuel complexes and abundances over time) and thus the decision was made to only model potential wildfire behavior using present-day fuel conditions at local scales.

B.3 Selecting Events to Model at Local Scales

We model flooding exposure in extreme events during each period of analysis. In each period, we identified one extreme per scenario (i.e. from the combinations of RCPs, GCMs, and probabilistic SLR). An extreme event for coastal flooding was a 72-hour window with the highest sea level during a 20-year period under a scenario. For a modeled area, a total of 120 events were identified for the 24 coastal flooding scenarios and 5 periods of analysis. We model an extreme event for inland flooding as a day with the highest daily rainfall intensity during a 20-year period under a scenario. For a modeled area, a total of 40 events were identified for the 8 inland flooding scenarios and the 5 periods of analysis.

Local, or asset-scale modeling of wildfire related hazards focused on wildfires that had potential to occur under the most extreme weather conditions. We used observed weather and fuel bed conditions during large, high severity wildfires that had occurred in California in the past. Extreme wildfire weather conditions incorporated into our local-scale modeling included low relative humidities, hot temperatures, fast wind speeds, and, where it was appropriate to do so, foehn wind directions. Live and dead fuel moistures were set to the lowest observed values in different fuel types. The local-scale wildfire modeling did not use the dynamic elements (e.g. hourly sea level) that were incorporated into the inland and coastal flooding models.

B.4 Selecting Regions to Model at Local Scales

While we obtained and modeled flooding and wildfire exposures statewide, we also selected certain areas to model at local scale, mainly based on their hazard exposure and TFS asset concentration, the TFS stakeholders' advice, and fine-resolution data availability. The statewide models were at spatial resolutions between 50 m (164 ft) and 6.2 km (3.85 miles), which were still too coarse for identifying asset level exposure. The local or asset scale models were conducted at 5 m (16.4 ft) spatial resolution, allowing more detailed analysis of flooding and wildfire exposure.

Locally modeled areas for flooding exposure were mainly located in flat areas along the California Coast. We found concentrations of TFS assets, particularly refineries, terminals, and some pipes, along the Coast. The coast was also found exposed to flooding mainly from sea level rise and storm surge. With additional inputs from the TFS stakeholders, we selected areas in Brisbane, Richmond, Concord and Martinez in Northern California, and Port of Long-Beach in Southern California to conduct local-scale modeling for both coastal and inland flooding. Results of these areas are included in Appendix C.

Wildfire events have been well distributed throughout California since times that predate the arrival of Euro-Americans, and this pattern is not expected to change between the present time and 2100. Local scale wildfire model focused on the immediate vicinity of TFS assets that transported and delivered sector inputs and outputs to production, storage, and distribution facilities located throughout the State. Specifically, the model was conducted in asset-containing areas that were identified as critical to the TFS during stakeholder outreach. In addition to the stakeholder identified areas of interest, selected areas were modeled at local scales to demonstrate the range of potential wildfire behaviors in all land cover types in California (i.e. forests, woodlands, shrublands, and grasslands). Results of the local scale wildfire model are included in Appendix D.

B.5 References

- Bjørnæs, C. (2013). *A guide to Representative Concentration Pathways*. CICERO. Center for International Climate and Environmental Research.
- Cayan, D. R., Kalansky, J., Iacobellis, S., & Pierce, D. (2016). *Creating Probabilistic Sea Level Rise Projections to support the 4th California Climate Assessment* (No. 16- IEPR-04). California Energy Commission. Retrieved from http://docketpublic.energy.ca.gov/PublicDocuments/16-IEPR-04/TN211806_20160614T101823_Creating_Probabilistic_Sea_Leve_Rise_Projections.pdf
- DeConto, R. M., & Pollard, D. (2016). Contribution of Antarctica to past and future sea-level rise. *Nature*, 531(7596), 591–597. <https://doi.org/10.1038/nature17145>
- DWR, & CCTAG. (2015). *Perspectives and Guidance for Climate Change Analysis*. California Department of Water Resources (DWR), Climate Change Technical Advisory Group (CCTAG).
- Kopp, R. E., Horton, R. M., Little, C. M., Mitrovica, J. X., Oppenheimer, M., Rasmussen, D. J., ... Tebaldi, C. (2014). Probabilistic 21st and 22nd century sea-level projections at a global network of tide-gauge sites. *Earth's Future*, 2(8), 2014EF000239. <https://doi.org/10.1002/2014EF000239>
- Lesthaeghe, R. (2014). The second demographic transition: A concise overview of its development. *Proceedings of the National Academy of Sciences*, 111(51), 18112–18115.
- Masui, T., Matsumoto, K., Hijioka, Y., Kinoshita, T., Nozawa, T., Ishiwatari, S., ... Kainuma, M. (2011). An emission pathway for stabilization at 6 Wm⁻² radiative forcing. *Climatic Change*, 109(1–2), 59. <https://doi.org/10.1007/s10584-011-0150-5>
- Moss, R. H., Babiker, W., Brinkman, S., Calvo, E., Carter, T., Edmonds, J., ... Hibbard, K. (2008). *Towards New Scenarios for the Analysis of Emissions: Climate Change, Impacts and Response Strategies*. Intergovernmental Panel on Climate Change Secretariat (IPCC).
- Moss, R. H., Edmonds, J. A., Hibbard, K. A., Manning, M. R., Rose, S. K., van Vuuren, D. P., ... Wilbanks, T. J. (2010). The next generation of scenarios for climate change research and assessment. *Nature*, 463(7282), 747–756. <https://doi.org/10.1038/nature08823>
- Pierce, D., Cayan, D. R., & Dehann, L. (2016). *Creating Climate projections to support the 4th California Climate Assessment* (No. 16- IEPR-04). California Energy Commission. Retrieved from http://www.energy.ca.gov/2016_energypolicy/documents/2016-06-21_workshop/2016-06-21_documents.php
- Riahi, K., Rao, S., Krey, V., Cho, C., Chirkov, V., Fischer, G., ... Rafaj, P. (2011). RCP 8.5 – A scenario of comparatively high greenhouse gas emissions. *Climatic Change*, 109(1–2), 33. <https://doi.org/10.1007/s10584-011-0149-y>
- Sharygin, E. (2017). Modeling methodology for the 2016 baseline California population projections.

- Sleeter, B. M., Wilson, T. S., Sharygin, E., & Sherba, J. T. (2017). Future Scenarios of Land Change Based on Empirical Data and Demographic Trends: LAND USE PROJECTIONS FOR CALIFORNIA. *Earth's Future*. <https://doi.org/10.1002/2017EF000560>
- Thomson, A. M., Calvin, K. V., Smith, S. J., Kyle, G. P., Volke, A., Patel, P., ... Edmonds, J. A. (2011). RCP4.5: a pathway for stabilization of radiative forcing by 2100. *Climatic Change*, 109(1-2), 77. <https://doi.org/10.1007/s10584-011-0151-4>
- Vuuren, D. P. van, Edmonds, J., Kainuma, M., Riahi, K., Thomson, A., Hibbard, K., ... Rose, S. K. (2011). The representative concentration pathways: an overview. *Climatic Change*, 109(1-2), 5. <https://doi.org/10.1007/s10584-011-0148-z>
- Westerling, A. L. (forthcoming). Wildfire Scenario Projections in California's Fourth Climate Change Assessment. 4th Assessment report or white paper.

APPENDIX C: FLOODING DATA, METHODS, AND RESULTS

C.1 Introduction

In this study, we modeled flooding induced by climate drivers including sea level rise (SLR), intensified storms, increased precipitation and runoff (**Figure C 1**), and produced maps of inundation extent and depth as our metrics for flooding exposure. Taking the Fourth Assessment sea level and climate projections between 2000 and 2100 as the inputs, we modeled over multiple planning horizons and climate scenarios. First, we modeled every 20 years between 2000 and 2100, allowing our results to inform TFS stakeholders' near-term and long-term planning. Second, the inclusion of multiple climate scenarios, including two emission scenarios (i.e. Representative Concentration Pathways (RCP) 4.5 and RCP 8.5), four General Circulation Models (GCMs, i.e. HadGEM2-ES, CNRM-CM5, CanESM2, MIROC5; see **Table B 2** in Appendix B), and three percentile estimates of SLR (i.e. 50%, 95%, 99.9%), provide the basis to understand the range of long-term climate projections and environmental disaster exposure.

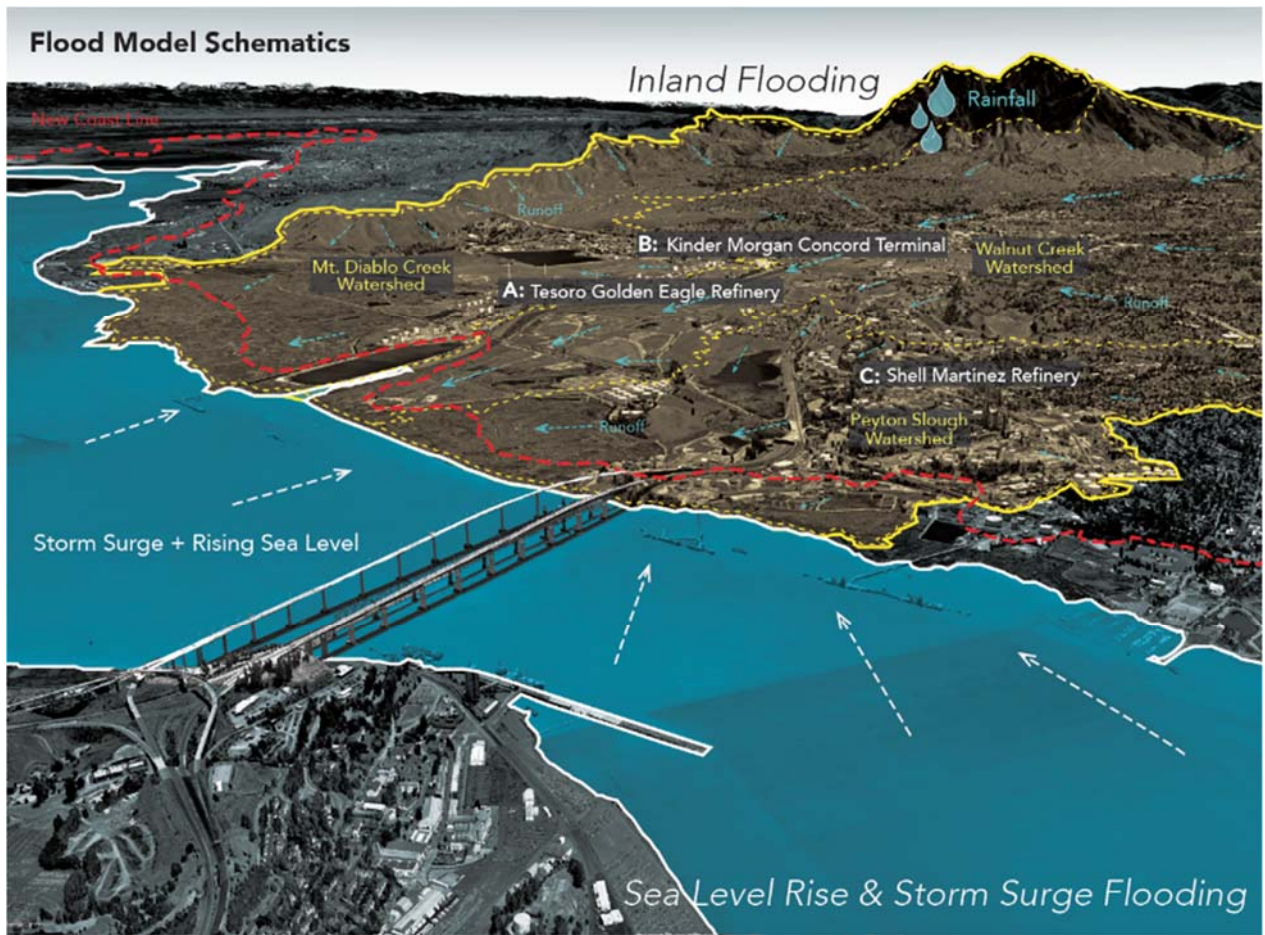

Figure C 1. Flood Model Schematic. We model coastal flooding exposure due to SLR and storm surge, and inland flooding from rainfall and surface runoff. Coarse resolution models were first conducted to assess statewide, long-term, multi-temporal, and multi-scenario flooding exposure, while fine resolution models were only conducted in areas, planning horizons, and climate scenarios with severe flooding exposure and TFS concentration informed from the coarse resolution model.

The overview of the flooding models is illustrated in

Table C 1. We modeled two types of flooding (i.e. coastal and inland) and at two spatial scales (i.e. regional versus local). In each combination of study areas and spatial scales, we identified a suitable approach and specifications that could feasibly and accurately perform the modeling: (1) For the regional coastal model, we employed a process-based, hydrodynamic approach, and modeled flooding during the highest storm events from the hourly sea level projections produced by (Cayan et al., 2016); (2) For local coastal and inland flooding models, we employed the same hydrodynamic approach as for the coarse-resolution coastal model. Due to the high computational cost, the fine resolution model was only conducted in areas with high TFS concentration and severe flood exposure identified from (1).

Table C 1. The overall flood-modeling framework. This table illustrates the areas of interest, model resolution, and the corresponding modeling approach including the model, input, and output.

	Areas of interest	
	Coastal	Inland
Climate drivers	<ul style="list-style-type: none"> • SLR, storm, and tide 	<ul style="list-style-type: none"> • Rainfall and runoff
Regional (coarse) resolution model	<ul style="list-style-type: none"> • Hydrodynamic modeling (3Di, TU Delft); • 50 m spatial resolution; • Iterated over 24 scenarios from a combination of 2 RCPs, 4 GCMs, and 3 percentile SLR projections • For each scenario: <ul style="list-style-type: none"> ○ Modeled coastal flooding during the highest sea level events (i.e. a 72-hour window) every 20 years, between 2000 and 2100; ○ Produced a map of maximum flooding extent and depth during the event. 	(not modeled)
Local (fine) resolution model	<ul style="list-style-type: none"> • Hydrodynamic modeling (3Di, TU Delft) of SLR, storm surge, rainfall, and runoff; • 5 m spatial resolution; • Modeled coastal flooding during the highest sea level events (i.e. 72-hour windows) informed from the regional coastal model, and inland flooding under the highest daily rainfall events (i.e. 24-hour windows) from Localized Constructed Analogs (LOCA). • To reduce computation cost: <ul style="list-style-type: none"> ○ The model was only conducted in selected areas with high TFS infrastructure concentration and flooding exposure. Examples of such areas include Port of Long Beach, Concord-Martinez, Richmond, and Kinder Morgan, Inc. Brisbane terminal; ○ The model was conducted for the period between 2020 and 2040 to measure near-term flooding exposure, and the period between 2080-2100 for the long term; ○ The modeled was iterated over events under high, medium, and low scenarios informed from the regional models. ○ Produced a map of maximum flooding extent and depth during the event. 	

In this appendix we first introduce the datasets, including climate scenarios, topography and bathymetry models, and other environmental datasets used by both coastal and inland flood modeling in section C.2. Section C.3 describes the methods for coastal and inland flood modeling respectively. In section C.4, we show results from coastal and inland models at both regional and local scales. Finally, section C.5 discusses the implications of our results for the TFS sector, uncertainties from multiple climate scenarios, and possible directions for future work.

C.2 Data

Various datasets have been used in this project for different modeling purposes. This section divides the datasets into three categories: (a) climate scenarios including sea level and weather variable projections, (b) topography and bathymetry models, and other environmental datasets including land cover, soil, streams, and (c) historical weather observations.

C.2.1 Climate Scenarios

Projections of sea level and weather variables drive our model to simulate future flooding exposures. These projections were made for multiple climate scenarios derived from combinations of different RCPs, GCMs, and percentiles of SLR.

C.2.1.1 SLR and Coastal Storm Scenarios

To simulate coastal flooding driven by rising sea level, intensified storms, and tides, we modeled high sea level events from the hourly sea level projections by (Cayan et al., 2016). These projections by Cayan et al. (2016) provide hourly sea level continuously between 1950 and 2100 at nine locations with long-term, reliable, and continuous tide gauge data. The nine locations are highlighted with red dots in **Figure C 2**. The hourly sea level projections were generated respectively for 24 climate scenarios that were combinations of two RCPs, three SLR scenarios, and four GCMs (**Figure C 3**). These projections are relative to the stations' mean sea levels measured under the most recent national tidal datum epoch (1983-2001). We made conversions between the mean sea levels and the National Elevation Dataset 88 (NAVD 88) for these projections to make them comparable with other datasets under NAVD 88.

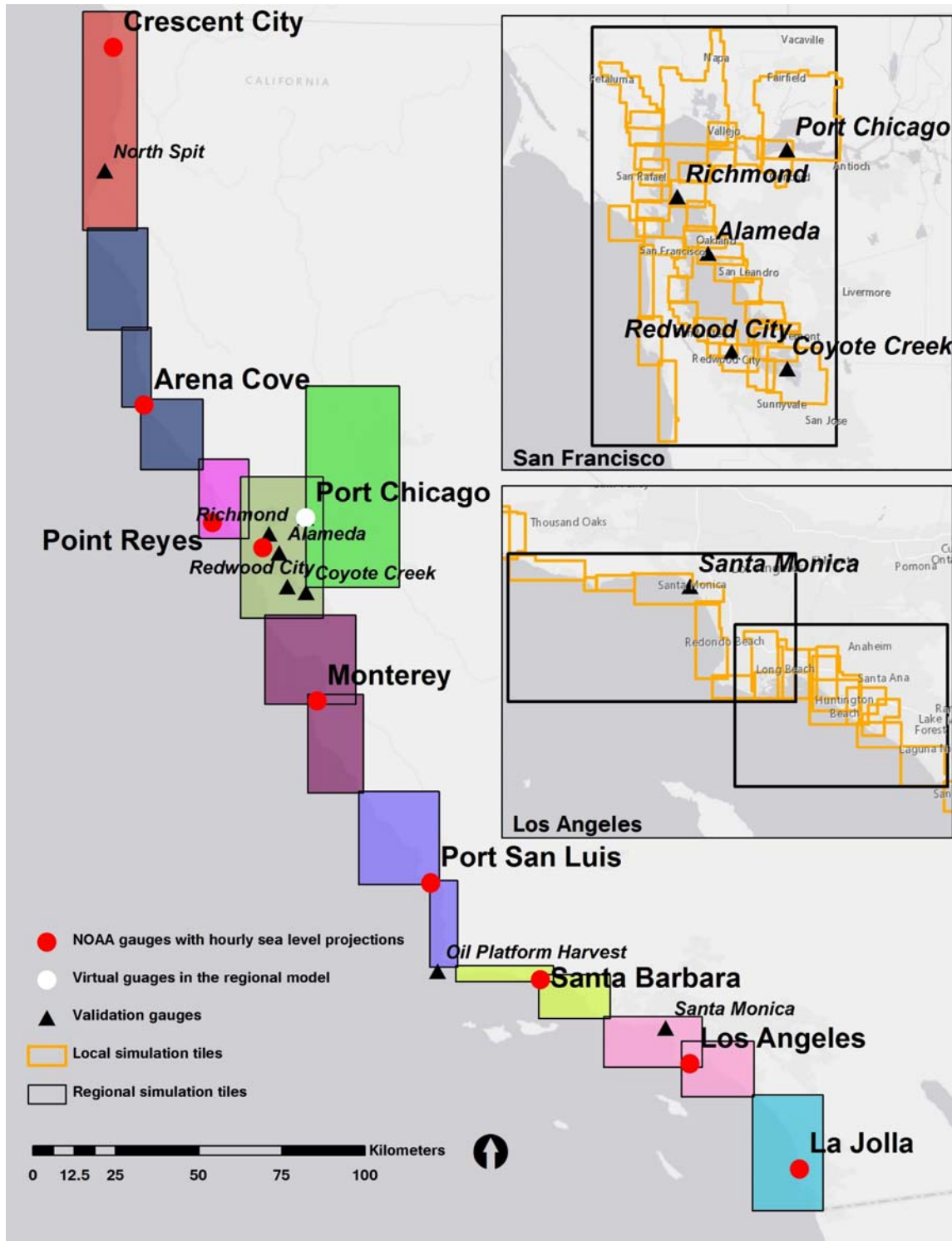

Figure C 2. NOAA tidal gauges with hourly sea level projections, virtual tidal gauges, validation tidal gauges, and regional and local simulation tiles. Most regional tiles take hourly sea level projections from their closest NOAA gauge, while the Sacramento – San Joaquin tile takes hourly sea level recorded at the Port Chicago virtual tidal gauge during the San Francisco Bay tile simulation. Validation gauges were used to validate the model with historical flooding events. The regional tiles are outlined in black and the color fill shows the adjacent tiles taking inputs from the same NOAA/virtual gauge. The zoom-in maps show the local simulation tiles within the regional tiles.

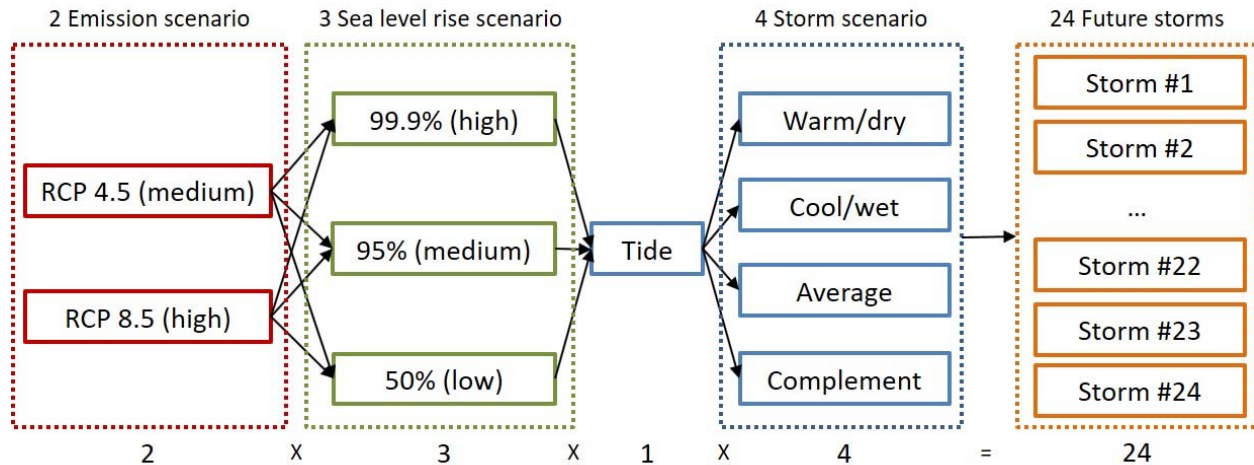

Figure C 3. SLR and coastal storm scenarios used in this study

The hourly sea level projections are combinations of short-term sea level fluctuations and long-term SLR (Cayan et al., 2016). The long-term SLR is projected probabilistically by Cayan et al. (2016) based on a method proposed by Kopp et al. (2014) with additional SLR contributions from loss of Antarctica ice sheets modeled by DeConto & Pollard (2016). The Kopp et al. (2014) method uses the Latin hyper-cube to sample time-dependent probability distribution of five primary global SLR components including land surface water contributions, contributions from glaciers and ice caps, oceanographic process, and contributions from Greenland ice sheets. Under RCP 8.5, contributions from Antarctica ice sheets projected by DeConto & Pollard (2016) were included as an additional component. After the sampling, 50th percentile, 95th percentile, and 99.9th percentile SLR projections were incorporated in the final hourly sea level projections for the Fourth Assessment. The SLR projections are relative to the year 2000 sea level. In addition to the long-term SLR, Cayan et al. (2016) combined tide, El Nino Southern Oscillation (ENSO) influence, and climate and weather inputs from the four GCMs to produce the short-term fluctuations. Finally, Cayan et al. (2016) added the short-term fluctuations to the long-term SLR to create the hourly sea level projections.

C.2.1.2 Rainfall Scenarios

We modeled inland flooding using rainfall estimates from the climate projections by Pierce, Cayan, & Dehann (2016). The projections provide daily, 1/16-degree (about 6.2-km or 3.85-mile) spatial resolution estimates of various climate variables over the entire state of California. These projections were made daily under both RCP 4.5 and RCP 8.5, for each of the 32 GCMs selected from the Climate Model Intercomparison Projection, version 5 (CMIP5) archive. We used rainfall projections from the four priority GCMs recommended by the 4th Assessment. For each variable, we obtained the values in eight scenarios that were combinations of the four GCMs and the two RCPs to represent future weather and climate conditions Figure C 4.

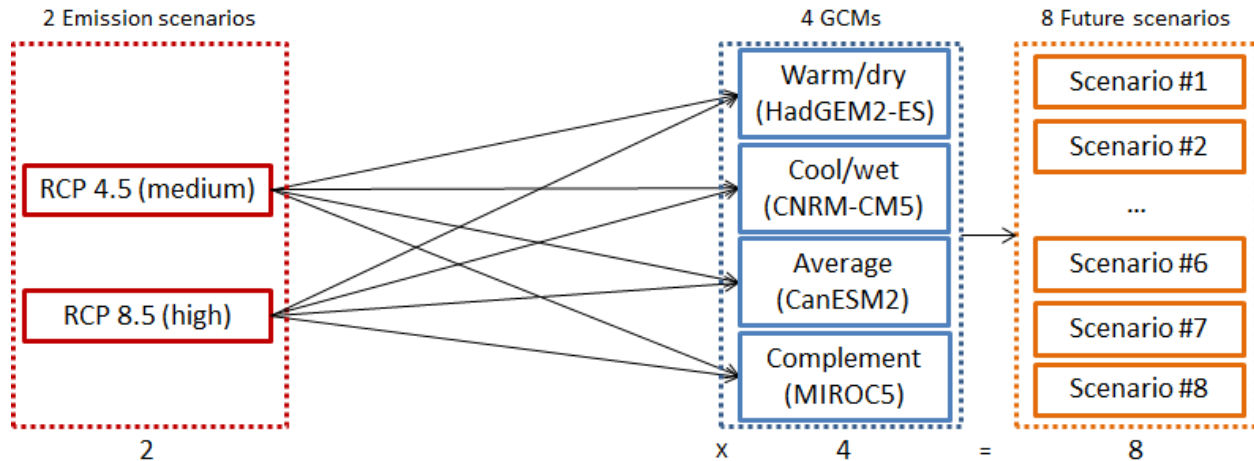

Figure C 4. Rainfall scenarios used in this study

The climate projections by Pierce et al. (2016) utilize two models. The first is a downscaling and bias correction model, LOCA, which transforms the GCM's projections from the global scale to the regional scale. While the GCMs provide fundamental information about the future global climate, they cannot be used directly for the state of California due to their systematic errors (i.e. bias, or systematic over/under-estimations for a particular geography such as California) and coarse spatial resolutions. Therefore, Pierce et al. (2016) applied the LOCA method to correct the bias and to refine the spatial resolution to 1/16 degree. However, GCMs and their outputs through the LOCA only provide a limited set of meteorological variables, including precipitation, daily maximum temperature, and daily minimum temperature, which are insufficient for some impact studies. Therefore, Pierce et al. (2016) used the LOCA outputs to drive a second model, Variable Infiltration Capacity (VIC) land surface model, to simulate additional climate variable such as rain, runoff, snow cover, soil moisture, etc. In this study, we used rainfall from the VIC outputs.

C.2.2 Topography and Bathymetry Data

Topography and bathymetry data were used as primary inputs for flood models. In this project, we used several topography and bathymetry models to build a continuous surface from the ocean to the inland. Finer-resolution datasets were used wherever they were available, and coarser-resolution datasets were used where fine-resolution datasets were absent. Depending on the spatial resolutions of the regional and local models, the fine and coarse resolution datasets were aggregated or resampled to achieve the target resolution.

Topography and bathymetry models in this project are listed in Table C 2, and their spatial coverages are illustrated in Figure C 5. The fine-resolution topography datasets are derived from Lidar (Light Detection and Ranging, which uses laser beams to scan the topography). The Lidar datasets cover the coastal landscape of the San Francisco Bay Area (i.e. USGS South Bay Lidar and NOAA North Bay Lidar), the majority of the Sacramento-San Joaquin Delta (i.e. DWR Sacramento - San Joaquin Delta Lidar), and the entire Californian coast (i.e. Coastal Conservancy Lidar and NOAA coastal topobathy merge that uses the Coastal Conservancy Lidar for the topography). We also included several fine resolution bathymetry datasets,

including DWR Bay-Delta bathymetry for the San Francisco Bay and the Sacramento – San Joaquin Delta, and NOAA coastal topobathy merge covering the near-coast bathymetry for the Californian coast. In addition, we included several coarser resolution datasets to fill the gaps in the finer resolution datasets. We used 10-m (33-ft) National Elevation Dataset and 90-m (295-ft) SRTM datasets as supplementary topography datasets, and a 200-m (656-ft) CDFW bathymetry as the supplementary bathymetry dataset.

Table C 2. Topographic and bathymetric datasets used in this study

Data	Use in this project	Spatial resolution	Source
USGS South Bay Lidar	Fine resolution building heights and DEM in the coastal Bay Area	1 m	USGS California Coastal LiDAR Project
NOAA North Bay Lidar	Fine resolution building heights and DEM in the coastal Bay Area	1 m	NOAA California Coastal LiDAR Project
DWR Sacramento - San Joaquin Delta Lidar	Fine resolution building heights, DEM, and bathymetry, in the Delta	1 m	California Department of Water Resources
DWR Bay-Delta bathymetry	Fine resolution bathymetry for the Bay and the Delta	2 m - local 10 m - regional	California Department of Water Resources
NOAA coastal topobathy merge	Fine resolution DEM and bathymetry mosaic along the Coast	1 m	2013 NOAA Coastal California TopoBathy Merge Project Digital Elevation Model (DEM)
Coastal Conservancy Lidar	Fine resolution building heights along the Coast	1 m	2009-2011 CA Coastal Conservancy Lidar Project
National Elevation Dataset (NED)	Supplement dataset where finer resolution DEM not present	10 m	USGS National Elevation Dataset
SRTM elevation data	Alternative dataset to NED	90 m	The Shuttle Radar Topography Mission (SRTM) digital elevation dataset
CDFW bathymetry	Supplement dataset where finer resolution bathymetry not present	200 m	California Department of Fish and Wildlife (CDFW) Marine GIS Unit (2007) bathymetry

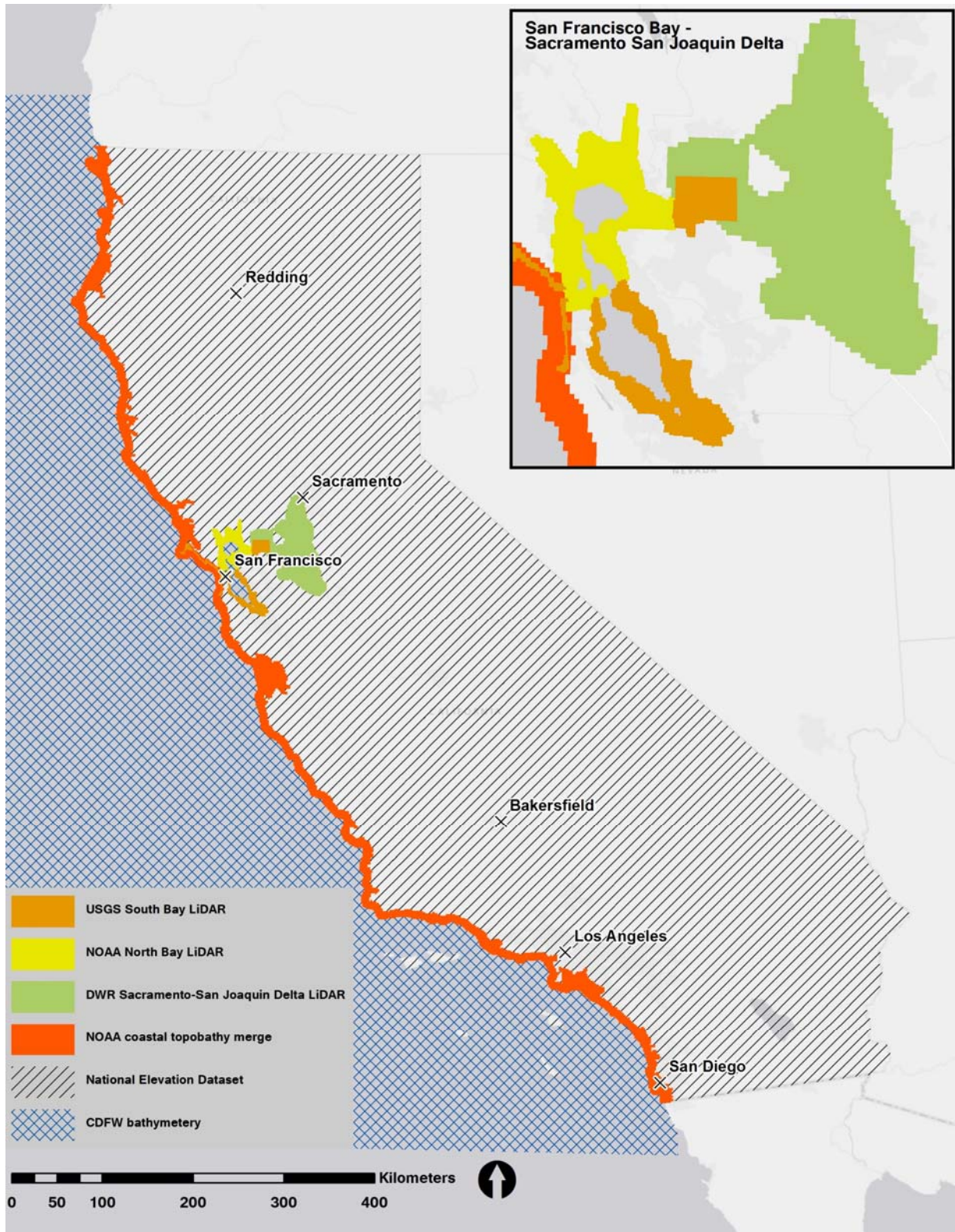

Figure C 5. Map of various topographic and bathymetric data used in this study

We generated continuous surfaces containing bathymetry and topography at 5 m (16.4 ft) and 50 m (164 ft) spatial resolutions. The 5-m (16.4-ft) surface contains bare ground elevations (i.e. digital elevation model, DEM), bathymetry, and aboveground object elevations (i.e. built structures such as buildings). The 50-m (164-ft) surface is like the 1-m (3.3-ft) surface, except that the 50-m (164-ft) surface doesn't include building objects. We excluded buildings as they could be too granular to be represented in a 50-m (164-ft) surface. However, flooding prevention features such as levees were preserved in the 50-m (164-ft) surface. Before building these two surfaces, we mosaic fine resolution topography and bathymetry data in the San Francisco Bay Area and Sacramento- San Joaquin Delta to generate a 1-m (3.3-ft) Bay-Delta topobathy merge that was equivalent to the 1-m (3.3-ft) NOAA coastal topobathy merge. The workflow for generating the 5-m (16.4-ft) and 50-m (164-ft) surfaces is illustrated in Figure C 6

Figure C 6 and described in the subsequent paragraphs.

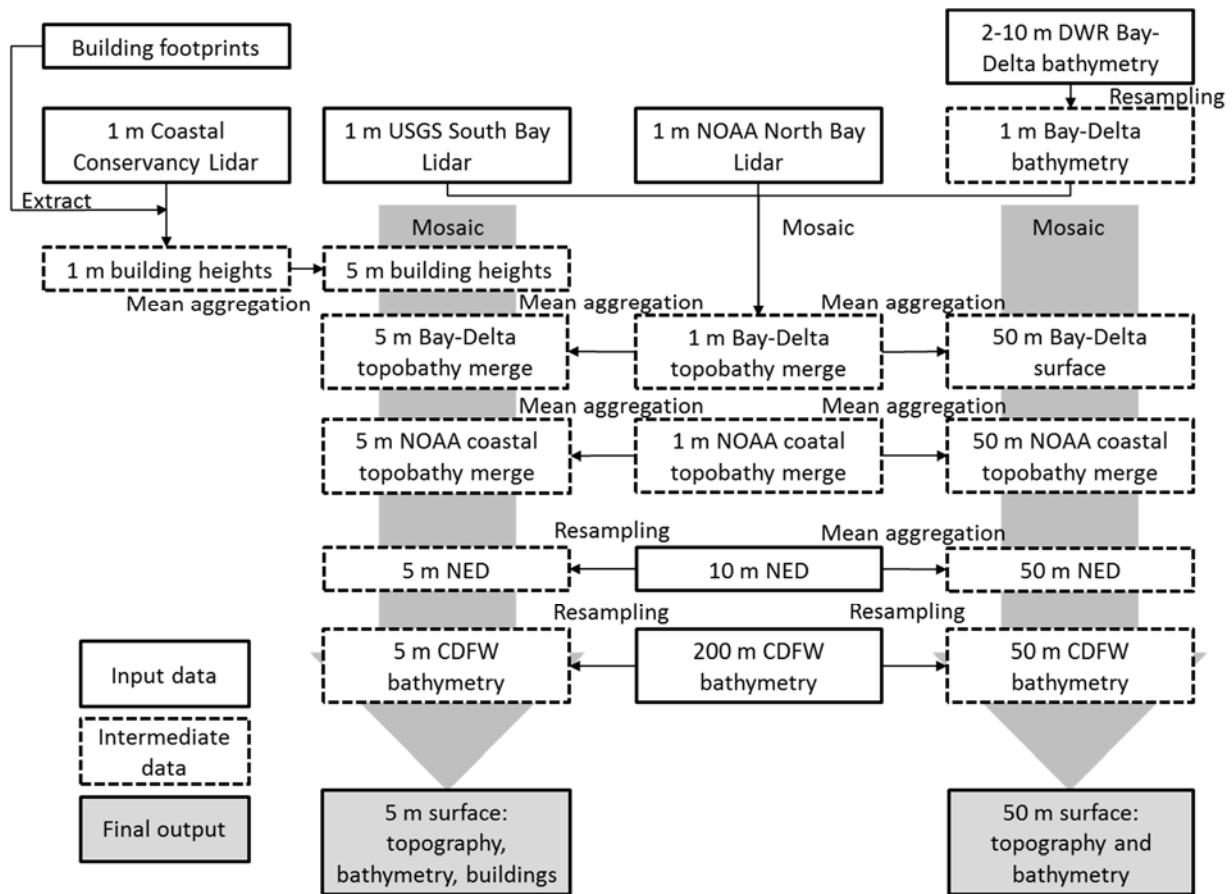

Figure C 6. The workflow to generate fine (5-m; 16.4-ft) and coarse (50-m; 164-ft) topography-bathymetry surfaces in this study

To build the 50-m (164-ft) surface, we aggregated the two 1-m (3.3-ft) topobathy merge and 10-m (33-ft) National Elevation Dataset individually using a mean aggregation and resampled the 200-m (656-ft) CDFW bathymetry using a cubic resampling to bring these surfaces to the same

50-m (164-ft) resolution. These aggregated and resampled surfaces were combined based on their original spatial resolutions where finer resolution surfaces were placed on top of coarser resolution ones. In this way, we ensured better quality data in terms of their resolution and accuracy were preserved in the final surface.

To build the 5-m (16.4-ft) surface, we first resampled the coarser resolution datasets including 10-m (33-ft) National Elevation Dataset and 200-m (656-ft) CDFW bathymetry to 5-m (16.4-ft) resolution. We then aggregated the two 1-m (33-ft) topobathy merge to 5-m (16.4-ft) resolution using the mean aggregation. Finally, we put the aggregated topobathy on top of the resampled Nation Elevation Data and CDFW bathymetry and produced a continuous 5-m (16.4-ft) surface. In addition, we added building elevations to the 5-m (16.4-ft) surface as we considered these objects would affect water flow in the flooding simulation.

Building elevations were extracted using LiDAR data from a dataset of building footprints that we developed. We defined low-lying watershed areas within which we needed to produce building footprints by using the flooding extent of the coarse resolution flood modeling. For certain areas within this extent, local municipal authorities provided building footprints to us. For other areas building footprints were not readily available and we had to extract them from survey data, such as imagery, raster elevation models, and LiDAR scans. We delineated some building footprints by digital image processing, by hand, or by a combination of both. We produced most of building footprints in areas not covered by local municipal datasets by extracting them from lidar scans using a parameter-based tool called "Feature Extractor."

Within a given extent where we sought to produce building footprints, applicable 1m (3.3-ft) Lidar data acquired for the project (**Table C 2**) was imported into the Feature Extractor along with a configuration file containing pre-set parameters. Shapes of the buildings were extracted from the lidar point cloud based on the parameter specifications given to the tool. These parameters included smoothness of the building roof, maximum and minimum angles that building walls can assume, how much of the building edges could tolerate overhanging trees, as well as several optional parameters such as minimum and maximum building height, or the building's area. To create object polygons most accurately represented the true shape and form of the buildings represented, we adjusted these parameters and applied one set of parameters for urban areas and a separate set for residential areas. We separated these types of regions and assigned specific parameter values to each because these areas tend to have buildings with very different characteristics from one another. The primary individual parameters that differed between the parameter sets used for these two types of regions included the slope of building roof and degree to which a vertical edge could extend without changing its slope value.

Using the specified parameters and based on the characteristics of the input Lidar points, the Feature Extractor program then generated a shapefile of extracted building footprint polygons, which could be loaded into geographic information system software. The resultant building footprint polygons were close approximations of the actual building outlines. They did not match the exact footprint of the building, however (**Figure C 7**). These object polygons were then combined with a DEM to extract the height of each building. Finally, the building elevations were incorporated into a digital surface model (DSM) of the analysis area for input as topography into the fine resolution inundation modeling. Generating building footprints for the necessary flooded extent along entire coast of California took approximately ten weeks to complete.

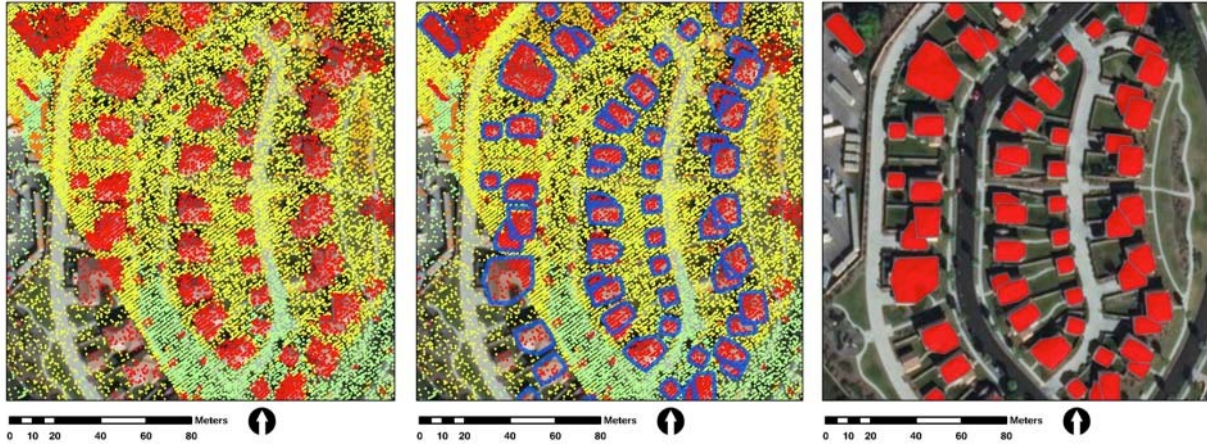

Figure C 7. Building footprints generated by “Feature Extractor” from LiDAR data. LiDAR points alone are shown over an aerial image in the left figure; building footprints generated by the feature extractor from the LiDAR points are shown in blue outline in the middle figure; and the footprints are shown over the aerial image alone in the right figure.

C.2.3 Other Environmental Datasets

In addition to the climate scenarios and topography-bathymetry datasets above, we acquired datasets describing land cover, soil texture, and watershed boundaries for the entire state of California, which are summarized in Table C 3.

Table C 3. Other environmental datasets used in this study

Dataset	Description	Source
Land cover	Physical material that covers the earth surface, including grass, tress, bare earth, development, water, etc. The dataset was used to derive other variables such as infiltration rate and Manning’s roughness coefficient.	National Land Cover Database 2011, United States Geological Survey (Homer et al., 2015)
Hydrological soil group	Assigns soils into groups based on runoff and infiltration potential.	SSURGO database, National Cooperative Soil Survey, United States Department of Agriculture (Soil Survey Staff, n.d.)
Hydrological units code, 12 digits (HUC-12)	Sub watershed boundaries	Natural Resource Conservation Service, United Sates Department of Agriculture (Natural Resource Conservation Service, 2017)

C.3 Methods

C.3.1 Regional-scale Coastal Flooding Model

C.3.1.1 Models for SLR and Storm Flooding

Several models have been developed to simulate inundation from SLR, storm surge, and coastal flooding. These models can be generally divided into two categories: static and hydrodynamic. Earlier models tend to be static, which treat the inundation as a snapshot produced by a certain water surface that does not vary by time. The static models are computationally feasible, therefore can be easily applied to large scales and with fine resolution datasets. However, these models ignore the temporal dynamics where water level changes over time due to storms and tides. One popular static model is the ‘bathtub’ model that simply finds areas below the projected water surface (Dasgupta, Laplante, Meisner, Wheeler, & Yan, 2008). Often, projected water levels from gauges are used to interpolate this water surface. However, this ‘bathtub’ model tends to overestimate the inundation, as the model considers no hydrologic connectivity and may cause some low-lying but isolated (i.e. not connected to any water body) areas be inundated. A further step from the ‘bathtub’ model is the ‘pathway’ model that uses connectivity rules to identify water flow pathways and then corrects for the low-lying but isolated areas (Poulter & Halpin, 2008). Several studies, such as NOAA’s SLR Viewer (Marcy et al., 2011), Climate Central’s tidally adjusted SLR and flooding map (Strauss, Ziemiński, Weiss, & Overpeck, 2012), Climate Central’s tidally adjusted SLR and flooding map (Biging et al., 2012), have adopted the ‘pathway’ model.

More recent research has employed process-based, hydrodynamic, 2-dimensional (2D) models that simulate flooding during storm events combined with SLR. However, 2D hydrodynamic models are computationally expensive and therefore difficult to be implemented at regional scales. Two studies have conducted 2D hydrodynamic models for the State of California. The Coastal Storm Modeling System (CoSMoS) (Barnard et al., 2009, 2014) use a combination of 1D X-Beach model and 2D Delft3D model to simulate flooding from incremental SLR every 0.5 m (1.64 ft) between 0 (0 ft) and 5 m (16.4 ft) combined with different return-interval storms and King tides. The CalFloD-3D model, by Radke et al. (2014), used a hydrodynamic model 3Di (Stelling, 2012a) to simulate a near 100-year storm combined with 0 m (0 ft), 0.5 m (1.64 ft), 1.0 m (3.28 ft), and 1.41 m (4.63 ft) SLR. While these efforts have provided valuable information on SLR and coastal flooding, their incremental SLR scenarios do not exactly match with the Fourth Assessment scenarios characterized by specific time horizons, RCPs, GCMs, and percentile SLR.

In this study, we modeled SLR and coastal flooding mainly based on the CalFloD-3D model by Radke et al. (2014), but updated the model with the Fourth Assessment scenarios. Particularly, we modeled extreme events from the hourly sea level projections by Cayan et al. (2016) over the 24 SLR and coastal storm scenarios described in section C.2.1. We iterated the 24 scenarios over five planning horizons (i.e. 2000-2020, 2020-2040, 2040-2060, 2060-2080, and 2080-2100). For each iteration defined by planning horizons and climate scenarios, we produced a composite surface of maximum flooding depth and extent during the event as the output. The ensemble of these surfaces from different events and scenarios shows the potential flooding exposure in Californian coast due to climate changes.

Since the entire Californian coast is too vast to be hydrodynamically modeled with the 3Di in a single simulation, we employed a ‘two-stage, tile-by-tile’ modeling approach. The ‘tile-by-tile’ reference captures the fact that the modeling was conducted by tiles, and ‘two-stage’ refers to

the fact that we used a regional model and a local model. We delineated the tiles to cover low elevation coastal areas, with additional considerations on watershed boundaries, model resolution, tile size, and computational time. In the regional model (i.e. the first stage), we defined 16 tiles (outlined in black in **Figure C 2**) along the coast, with 15 of them taking the extreme events from the nearest gauges with the Fourth Assessment's hourly sea level projections (outlined as red dots in **Figure C 2**). The 16th tile covering the Sacramento – San Joaquin Delta took water levels recorded at a Port Chicago virtual gauge (outlined as a white dot in **Figure C 2**) during the San Francisco Bay tile simulation. We used separate tiles for the Bay and the Delta as the combined region was too large even for the regional model. In the local model (i.e. the second stage), we defined local simulation tiles within the regional tiles (examples are outlined in orange for the San Francisco Bay and Los Angeles tile in **Figure C 2**). The regional model simulated the extreme event water levels for the local model tiles. Section C.3.1.2 documents the regional model, while section C.3.2 documents the local model.

C.3.1.2 Regional Coastal Flooding Model with 3Di

We used the 3Di model (Stelling, 2012a), the core model in the CalFloD-3D (Radke et al., 2014), to simulate both regional and local scale coastal flooding. The 3Di model is a hydrodynamic model developed in the Netherlands by Delft University of Technology, Deltares, with Nelen & Schuurmans Consultants, and it dynamically simulates the movement of tides and flood events over digital representations of low-lying land surfaces. Model inputs mainly include time-series water levels as boundary forcing, and surface data containing land surface elevation, bathymetry, and/or aboveground objects elevations. The model can simulate a storm event, in a series of time steps, the flow direction, velocity and water depth as the event progresses. The user defines the time step of the outputs and post-processing to combine the results. In this study, we defined an hourly time step and combined the output from each time step to generate the maximum extent and depth composite map as flooding exposure during the event.

Extreme Storm Events as Boundary Forcing

For every 20 years between 2000 and 2100, we modeled extreme storm events from the hourly sea level projections by Cayan et al. (2016) in each of the 24 climate scenarios (i.e. combinations of 2 RCPs, 4 GCMs, and 3 percentile SLR, as identified in section C.2.1). We used these 20-year planning horizons to match with TFS sector's planning and investment circles. An extreme event is a 72-hour period containing the highest sea level during a 20-year interval in a climate scenario. We identified for every gauge in **Figure C 2**, 120 events for the 24 climate scenarios and 5 planning horizons. The highest sea levels vary between different climate scenarios, as illustrated with the example for the San Francisco gauge (**Figure C 8**). At the San Francisco gauge, the highest sea levels under RCP 8.5 tend to be higher than those under RCP 4.5, which were likely due to stronger emissions under RCP 8.5. The range of the highest sea levels between different events also increases with time. For example, under RCP 8.5, the range between the highest and lowest estimates is 0.14 m or 0.46 ft (i.e. 2.63 m (8.63 ft) versus 2.49 m (8.17 ft)) during the 2000-2020 horizon, and the range increases to 1.72 m or 5.64 ft (5.50 m (18.04 ft) versus 3.78 m (12.40 ft)) between 2080 and 2100. A supplementary table is attached to see the range of the highest sea levels being modeled in this study.

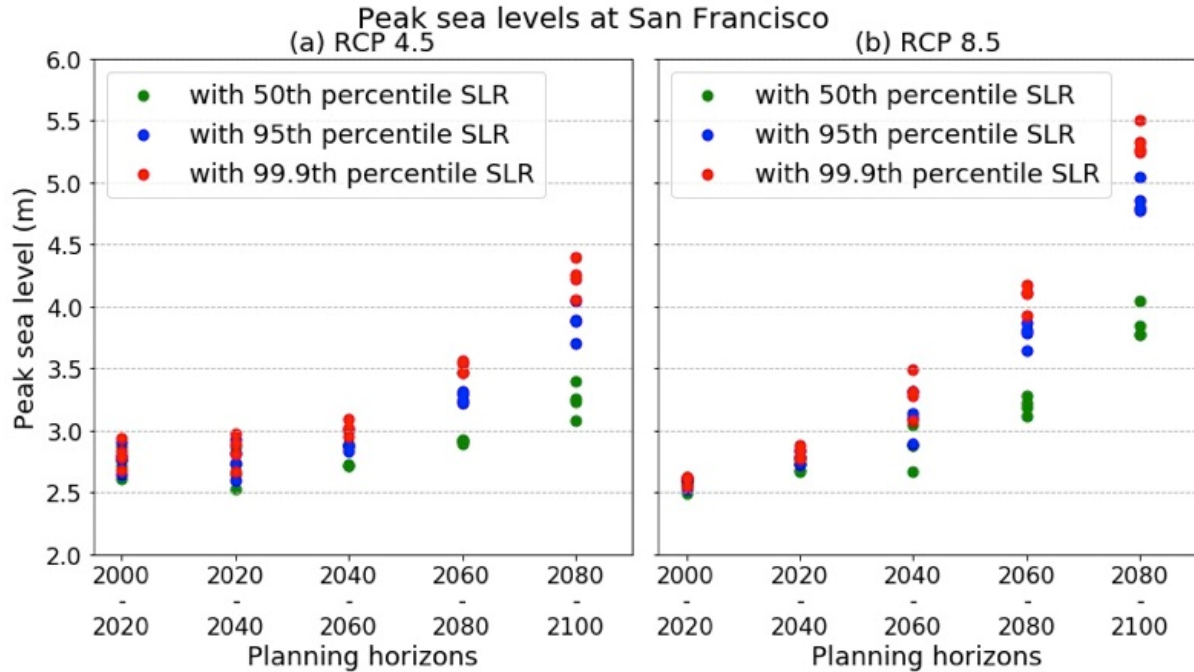

Figure C 8. Peak sea levels projected at the San Francisco gauge. Each dot represents the peak sea level by a RCP, GCM, and percentile SLR (shown by color) during a planning horizon. (a) shows peak sea levels under the RCP 4.5 scenario. (b) shows peak sea levels under the RCP 8.5 scenario.

To model the regional tiles along the Californian coast, we would ideally obtain the extreme event water levels for each tile’s boundaries. However, water level projections are only available at the nine NOAA gauges. Therefore, we assigned most tiles to their nearest gauge (the assignment is shown by color in **Figure C 2**) to simply approximate each tile’s water levels during the events. The Sacramento-San Joaquin Delta tile, however, was assigned to the Port Chicago virtual gauge, which recorded water levels during the adjacent San Francisco Bay tile simulation. In this way, we separated the Bay and the Delta into two tiles as we considered the combined Bay-Delta region was too large for the regional model. To estimate the uncertainties from this simple approximation, we first modeled historical events and validated the model by comparing simulated water levels against tidal gauges’ observations. These validation tidal gauges are outlined as squares in **Figure C 2**. The validation (**Figure C 9**) showed that the approximation and model setup could in general accurately simulate water level during historical events, with the correlation (calculated as equation (2)) between simulation and observation no less than 0.79 and root mean square error (RMSE, calculated as equation (2)) no greater than 0.69. We also noticed the differences between simulated and observed water levels were likely to increase when moving to inland areas. For example, in the San Francisco Bay Area, the difference between simulated and observed water levels were smaller for the near coast Alameda gauge (correlation = 0.92, RMSE = 0.31) than the ones further inland, such as Port Chicago gauge (correlation = 0.81, RMSE=0.57) and Coyote Creek gauge (correlation = 0.82, RMSE = 0.69). We also noticed time lags between the simulation and the observation, as it required a certain amount of time for the simulated high sea levels to pass through the gauges. When a 30-min lag was added, the differences between the simulation and the observation were reduced for most locations, and the lowest correlation increased from 0.79 (without lag) to 0.84

(with 30-min lag) and the highest RMSE decreased from 0.69 (without lag) to 0.54 (with 30-min lag).

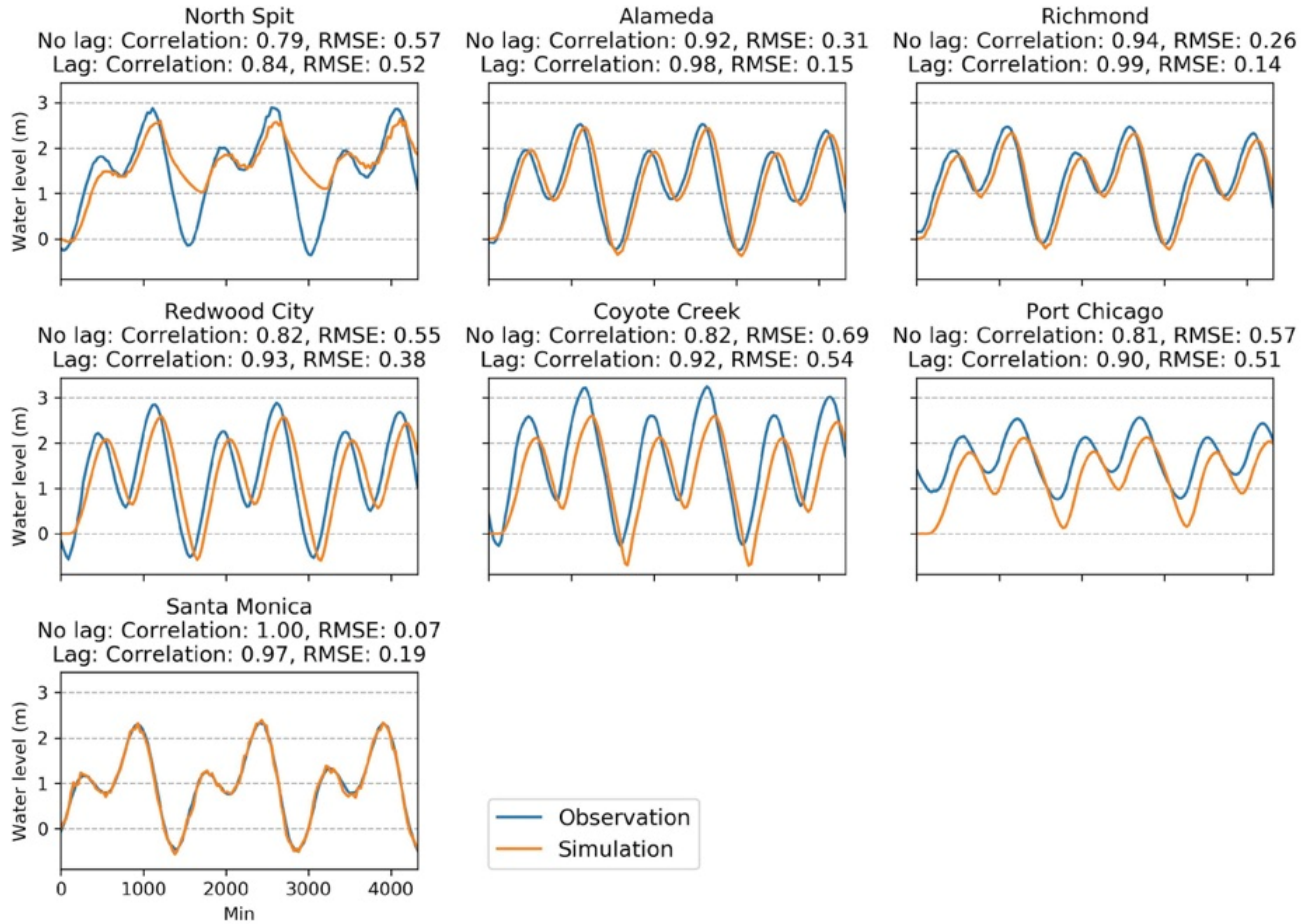

Figure C 9. Observed and simulated water levels during historical flooding events. Observation and simulation were compared using correlation and root mean square error (RMSE). Correlation and RMSE were calculated with and without a 30-min time lag.

$$r = \frac{\sum_{t=1}^n (x_t - \bar{X})(\hat{x}_t - \bar{\hat{X}})}{\sqrt{\sum_{t=1}^n (x_t - \bar{X})^2} \sqrt{\sum_{t=1}^n (\hat{x}_t - \bar{\hat{X}})^2}} \quad (1)$$

$$RMSE = \sqrt{\frac{\sum_{t=1}^n (\hat{x}_t - x_t)^2}{n}} \quad (2)$$

where x_t is the observed value at time step t , and \hat{x}_t is the simulated value, \bar{X} is the average value of the observations, $\bar{\hat{X}}$ is the average value of the simulations, n is the total number of time steps.

Surface Model

We used the 50-m (164-ft) surface described in Section C.2.2 as the surface data input. The 50-m (164-ft) surface incorporated both topography and bathymetry data but did not include aboveground objects such as buildings (shown in **Figure C 10**(c) where the buildings were

omitted) as they were often too granular to be represented at 50-m (164-ft) resolution. The 50-m (164-ft) surface might also sometimes insufficiently identify levees (shown in **Figure C 10(f)** where some levee segments seem ‘broken’), particularly in areas where a levee segment and its surroundings had very contrasting elevations. Since the 50-m (164-ft) surface used the mean aggregation that took mean values in a series of 50 by 50 m (164 by 164 ft) moving windows across the finer resolution elevation surfaces, the lower elevation surroundings could bring down the levee segment’s elevation in the final surface. One area with high concentration of such issue was the Sacramento-San Joaquin Delta, which had extensive levee structures protecting the low-lying land. In this region, we noticed some levee segments disappeared in the 50-m (164-ft) surface and created water flow pathways in the modeling.

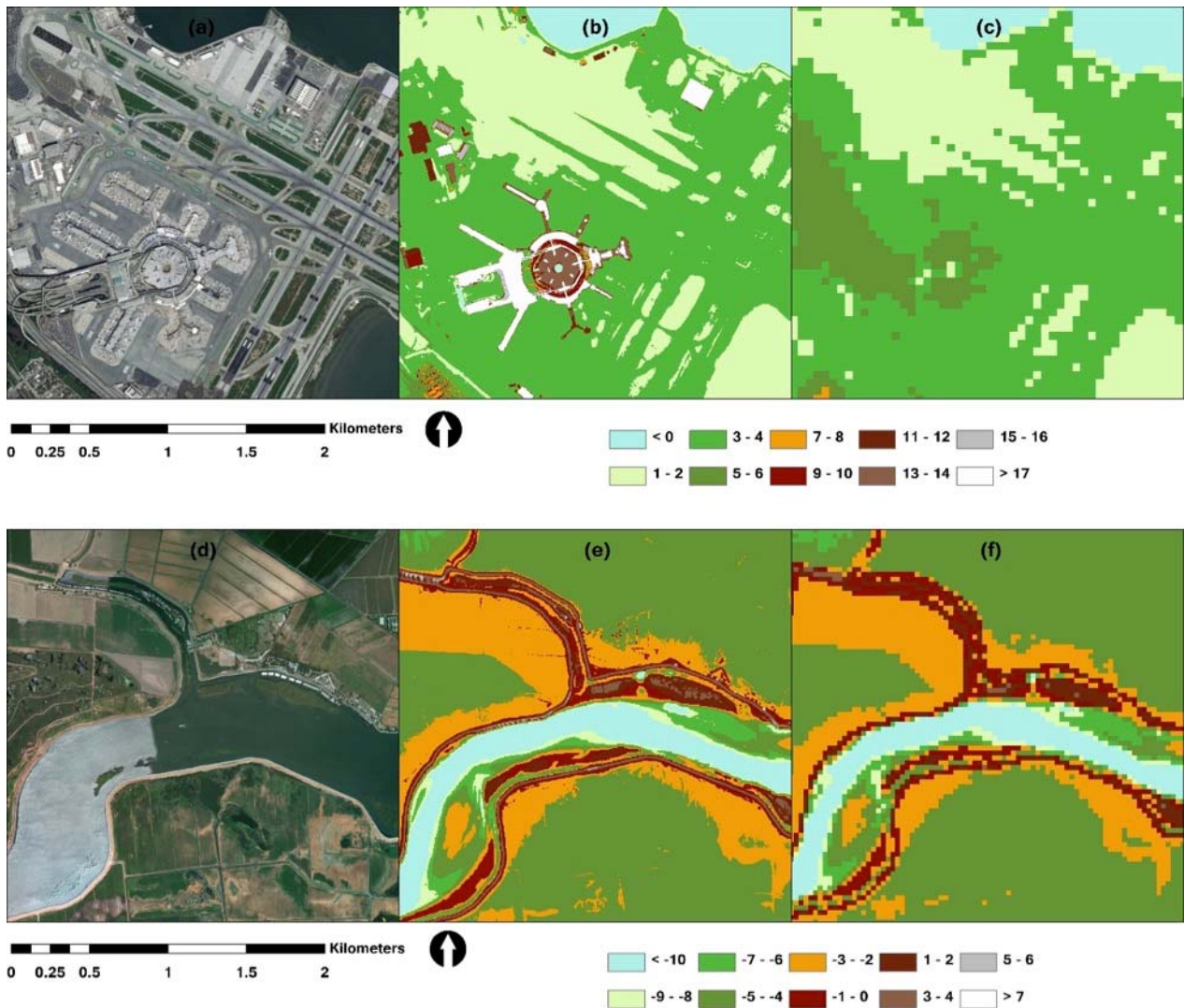

Figure C 10. Coarse and fine resolution elevation surfaces used in this study. (a) – (c) zoom to an urban area, whereas (d) – (f) zoom to a natural/rural area. (a) and (d) show the aerial images, (b) and (e) show the fine resolution, 5 m surfaces that include both land surface elevation, bathymetry, and aboveground objects such as buildings. (c) and (f) show the coarse resolution, 50 m surfaces that include only land surface elevation and bathymetry.

Parallel Processing

One run using the 3Di software produces results for a small spatial region. This analysis required many runs of 3Di to cover the extent of the State involved. Due to many such runs, it would be unnecessarily tedious and error-prone if the input data for each run were prepared by hand. To reduce human error and to handle launching multiple runs in parallel, we used a system called "Compute Farm." This system can maintain a group ("farm") of computers, assemble input data, perform pre-run checks and dispatch simulation runs to be executed on several computers at the same time.

Compute Farm can be operated from a web-based interface via the Internet. A computer that is recruited to be part of the Compute Farm communicates with the rest of the system in short sessions and, therefore, does not require network connectivity all the time. When a 3Di simulation is dispatched to a computer for execution, all necessary parts of the 3Di software, as well as all input data and other required files, are sent to that computer during the initial session. During the execution of a 3Di run, the computer can be queried for the status, progress, screenshots, available resources and so on. Once the execution is completed, the computer will send the results to a designated location, which may be a location on any other participating computer.

Depending on the input data, the 3Di simulation of one tile could take between several hours to several days. To meet our schedule, we built computers that have powerful CPUs with multiple cores. This allows us to run as many as 16 simulations on a single computer at the same time. Since the 3Di software runs are CPU-intensive and utilize multiple threads of execution per process (one simulation), the overall performance can be severely impacted by the wasteful context switches between multiple threads. To combat this problem, we had to achieve a balance between the physical processor cores and the number of threads in a 3Di process.

When started manually, a 3Di process will spawn as many threads as the number of cores available on a given computer. For this reason, if more than one 3Di process is started this way, several worker threads will compete for the same physical CPU core and will incur unwanted context switches. The Compute Farm system solves this problem by adjusting a process thread affinity before the process has had a chance to execute and decide regarding the number of threads to spawn. As a result, we were able to achieve nearly one to one ratio between the number of worker threads and CPU cores, thereby significantly improving performance and resource utilization. To set up a Compute Farm group of computers, we simply copied one executable file, a private key and a certificate to every participating Windows computer. Our choice of Windows as an operating system was imposed by the 3Di software requirements. In addition to Windows computers, we recruited several Unix/Linux computers, whose role was to host input data or receive simulation results. Compute Farm can take advantage of additional computers and use them as a fallback destination when a primary destination computer is not available.

Many of our computers were virtual machines. Due to a limited number of the Internet IP addresses, we set up a fast local network and created an access to individual computers via the network address translation (NAT). By doing this we could achieve a fully operational system, with the exception that when a fast local network link is available between two computers, the traffic still had to go through the gateways and the NAT system. This happened because every participating computer is known to the system by a unique IP address and that address is

different when a given computer is accessed from within a local network as opposed to accessing it from the Internet.

To prepare 3Di input data for every run of simulation, we wrote scripts that produced a comma-separated values (CSV) file that contains a set of file names and input parameters for one 3Di run per CSV file record. Creating the input data programmatically allowed us to achieve consistency and reduce human error as well as tedious work. Compute Farm can accept CSV files from its web-based interface and load them into a small built-in database. We used this database to automatically generate 3Di runs (we call them "tasks") and queue them for execution in the park of participating computers.

Model output

The model produced hourly flooding extents and depths during the 72-hour extreme events. We then combined the 72 hourly outputs from one extreme event to make a maximum flooding extent and depth composite. The composites from different events were then grouped by planning horizon, RCP, GCM, and percentile SLR to represent coastal flooding exposure in different time periods and climate scenarios.

We obtained from the regional model a second output that is the simulated water levels at the local tile boundaries. The water levels were used to represent local water levels during the extreme events and used as boundary forcing for the local model in section C.3.1.3. As previously discussed, the San Francisco regional model also simulated water level at the Port Chicago virtual tidal gauge, providing boundary forcing for the Sacramento-San Joaquin Delta regional tile's simulation.

C.3.2 Local-scale Models

We conducted local-scale models at 5-m (16.4-ft) spatial resolution only in certain areas of interest. We determined these areas by considering TFS assets concentration, flooding exposure in the regional-scale models, and suggestions from TFS stakeholders. The local models contained a coastal flooding model and an inland flooding model. Like the regional-scale coastal flooding model described in section C.0, both local-scale models (i.e. coastal and inland) used the 3Di (Stelling, 2012a) to dynamically simulate hourly flooding extents and depths during extreme events. Extreme events in the local-scale coastal flooding model were driven by SLR, storm, and tide, whereas the events in the inland flooding model were driven by daily rainfall. For each event, we made one maximum flooding extent and depth composite map from the hourly results to represent the flooding exposure.

C.3.2.1 Coastal Flooding Model

The local-scale coastal flooding model is similar to the regional-scale model (section C.3.1.2), as both models simulate extreme SLR and storm events over a continuous surface using the 3Di hydrodynamic model. For an area of interest, we identified the local tile (examples outlined in Figure C 2) where the area of interest is located and then conducted the simulation. Unlike the regional-scale model, the local-scale model used the 5-m (16.4-ft) surface model containing topography, bathymetry, and buildings as the continuous surface. This 5-m (16.4-ft) surface more accurately depicted the surface condition than the 50-m (164-ft) surface used by the regional-scale model. The differences between the two surfaces are illustrated in Figure C 10. However, the 5-m (16.4-ft) surface required more computation and therefore was only implemented in certain areas of interest. In addition, the local-scale model took water levels simulated by the regional-scale model during the extreme events as the local boundary forcing.

C.3.2.2 Inland Flooding Model

Delineating the Watersheds for Analysis

We modeled inland flooding in watersheds that overlapped with an area of interest, to capture the complete rainfall-runoff process draining to that area. Both Streamstats (<https://streamstats.usgs.gov/ss/>) and ArcGIS hydrology analysis (ESRI, 2016) were used for initial watershed delineations. Based on the initial delineations, we chose sub watershed from the Hydrologic Unit Code-12 (HUC-12) dataset to define the final watershed boundaries for modeling.

We defined the final watershed boundaries for areas of interest using the following steps. We first identified the main rivers and streams, as well as their discharge points, in that area. Since most of our areas of interest were located on the coast, the discharge points were mainly where the rivers/streams met the ocean. Second, we generated watersheds (or drainage areas) from the discharge points using both Streamstats and ArcGIS hydrological analysis and compared between them and HUC-12 sub-watersheds. In most cases, the two generated watersheds and HUC-12 sub-watersheds were consistent with each other, but their boundaries did not match exactly. Such mismatch could result from different input data and specifications used by the three data products. Since HUC has been used as a standard data product for many applications, we used the HUC-12 sub-watersheds as the final watershed boundaries.

Extreme Rainfall Events as Boundary Forcing

We retrieved extreme daily rainfall events from the LOCA projections (D. Pierce et al., 2016) as the model forcing in each of the watersheds identified above. For every climate scenario (i.e. one of the eight combinations of two RCPs and four GCMs) and 20-year interval (i.e. every 20 years between 2000 and 2100), we intersected the corresponding LOCA daily rainfall intensity projection surface with a watershed to calculate average rainfall daily intensity in that watershed. The highest average daily rainfall intensity was then used as the extreme event to feed the inland flooding model.

Surface Model

In addition to the 5-m (16.4-ft) topography, bathymetry, and aboveground objects surface used in the local-scale coastal flooding model, we incorporated detailed layers describing surface roughness and infiltration rate that could affect the rainfall-runoff process. We used Manning's coefficient to account for changes in surface roughness in the model. Manning's coefficient measures the amount of frictional resistance water experiences when passing over land and channel features (Vieux, 2001), and the coefficient's value is often assigned by land cover types. We used the land cover dataset from National Land Cover Database 2011 (USGS, 2014), and assigned Manning's coefficient accordingly. Table C 4 shows Manning's Coefficients for the land cover types in this study.

Table C 4. Manning’s Coefficients based on land cover types

Land cover type	Manning’s Coefficient	Land cover type	Manning’s Coefficient
Open water	0.0250	Evergreen forest	0.3200
Developed, open space	0.0404	Mixed forest	0.4000
Developed, low intensity	0.0678	Shrub/scrub	0.4000
Developed, medium intensity	0.0678	Grassland/herbaceous	0.3680
Developed, high intensity	0.0404	Pasture/Hay	0.3250
Barren land	0.0113	Woody wetlands	0.0860
Deciduous forest	0.3600	Emergent herbaceous wetlands	0.1825

Infiltration rate surfaces were also used to describe the velocity at which water entered the soil. In non-developed areas, infiltration rate is dependent on soil texture (% sand, silt, and clay) and clay mineralogy. We assigned infiltration rates based on the U.S. Department of Agriculture’s (USDA’s) hydrological soil groups. However, impervious materials with low infiltration rate mainly cover developed areas. Therefore, using land cover data from NLCD 2011, we assigned a separate set of infiltration rates to developed areas based on their development intensity. Finally, we merged infiltration rates from developed and non-developed areas to get a continuous layer as the model’s input. **Table C 5** shows the infiltration rates used in the study for developed and non-developed areas.

Table C 5. Infiltration rate based on hydrological soil group and developed land covers

Non-developed areas	Infiltration Rate (mm/day)	Developed areas	Infiltration Rate (mm/day)
Hydrologic Soil Group A	243.80	Developed, open space	106.68
Hydrologic Soil Group B	137.20	Developed, low intensity	64.01
Hydrologic Soil Group C	61.00	Developed, medium intensity	34.48
Hydrologic Soil Group D	15.20	Developed, high intensity	21.34

C.4 Flooding Exposure Analysis

In addition to the exposure analysis in Section 3.1.1 in the main report and supplementary table 2 and 3 in this appendix, we conducted a more detailed analysis of TFS’s exposure to flooding and demonstrated the uncertainties in the exposure introduced by the various climate

projections. To assess the impact of future coastal flooding associated with climate change, we overlaid the TFS assets with the flood depth layers generated by our flood models and calculated flooding exposure (lengths or areas of flooded assets) for the 20-year periods between 2000 and 2100. One distinction is to be made immediately: what we were analyzing here was the potential exposure of infrastructure to flooding, which was only the starting point of a risk assessment. A risk assessment would require the further analysis of probabilities and consequences (cost) of such flooding, which is affected by yet-to-be-determined management responses such as changes in operation, flood hardening, re-routing, or abandonment. Thus, this analysis was an evolutionary first step towards a better understanding of future flood risks.

C.4.1 Selection of Scenarios for Detailed Analysis

The coarse-scale model output for each of the climate scenarios analyzed (i.e. combinations of 2 RCPs, 4 GCMs, and 3 percentile SLR, as identified in section C.2.1.1) was an inundation depth surface for each 20-year period. These surfaces had 50-m (164-ft) spatial resolution, with each pixel having an elevation (Z) value of the maximum flooding depth in meters. We choose flood scenario inundation surfaces for subsequent more detailed exposure analysis by considering the range of flood severity effects produced by the 24 different model runs (corresponding to the 24 different climate scenarios) in a given 20-year time period between 2000 and 2100. Depending upon the purpose of the analysis, we selected minimum, median or maximum flood simulations as measured by the highest tidal heights produced by each of the 24 runs for the period. A simple sorting by predicted maximum tidal heights (**Table C 6**) allows us to identify the maximum, median, and minimum output flood surfaces for subsequent overlay with the transportation fuels infrastructure.

Table C 6. Example for the San Francisco Bay Area, 2080-2100: Sorted maximum tidal heights from all 3Di model runs.

RCP	GCM	SLR percentiles	Peak sea level (m)	Mean sea level (m) of the event	Time of the peak (start of the event)	End of the event	Scenario Rank
8.5	CanESM2	99.9	5.505	3.923	2098-02-14 18:00:00	2098-02-17 17:00:00	Max. Scenario
8.5	MIROC5	99.9	5.331	4.066	2099-02-10 11:00:00	2099-02-13 10:00:00	
8.5	CNRM-CM5	99.9	5.268	3.936	2099-01-07 19:00:00	2099-01-10 18:00:00	
8.5	HadGEM2-ES	99.9	5.243	4.211	2099-02-17 17:00:00	2099-02-20 16:00:00	
8.5	CanESM2	95.0	5.045	3.464	2098-02-14 18:00:00	2098-02-17 17:00:00	
8.5	MIROC5	95.0	4.862	3.597	2099-02-10 11:00:00	2099-02-13 10:00:00	
8.5	CNRM-CM5	95.0	4.800	3.469	2099-01-07 19:00:00	2099-01-10 18:00:00	
8.5	HadGEM2-ES	95.0	4.774	3.742	2099-02-17 17:00:00	2099-02-20 16:00:00	
4.5	MIROC5	99.9	4.401	3.026	2098-02-01 19:00:00	2098-02-04 18:00:00	
4.5	CanESM2	99.9	4.259	2.953	2099-02-04 18:00:00	2099-02-07 17:00:00	
4.5	CNRM-CM5	99.9	4.221	3.051	2096-01-24 18:00:00	2096-01-27 17:00:00	
4.5	HadGEM2-ES	99.9	4.061	2.886	2097-01-25 17:00:00	2097-01-28 16:00:00	Median Scenario
8.5	CanESM2	50.0	4.048	2.467	2098-02-14 18:00:00	2098-02-17 17:00:00	
4.5	MIROC5	95.0	4.044	2.668	2098-02-01 19:00:00	2098-02-04 18:00:00	
4.5	CanESM2	95.0	3.895	2.589	2099-02-04 18:00:00	2099-02-07 17:00:00	
4.5	CNRM-CM5	95.0	3.876	2.707	2096-01-24 18:00:00	2096-01-27 17:00:00	
8.5	MIROC5	50.0	3.841	2.577	2099-02-10 11:00:00	2099-02-13 10:00:00	
8.5	CNRM-CM5	50.0	3.781	2.450	2099-01-07 19:00:00	2099-01-10 18:00:00	
8.5	HadGEM2-ES	50.0	3.778	2.427	2096-01-08 18:00:00	2096-01-11 17:00:00	
4.5	HadGEM2-ES	95.0	3.710	2.535	2097-01-25 17:00:00	2097-01-28 16:00:00	
4.5	MIROC5	50.0	3.402	2.026	2098-02-01 19:00:00	2098-02-04 18:00:00	
4.5	CNRM-CM5	50.0	3.264	2.095	2096-01-24 18:00:00	2096-01-27 17:00:00	
4.5	CanESM2	50.0	3.238	1.932	2099-02-04 18:00:00	2099-02-07 17:00:00	
4.5	HadGEM2-ES	50.0	3.083	1.908	2097-01-25 17:00:00	2097-01-28 16:00:00	Min. Scenario

From tables like **Table C 6**, we select scenarios for subsequent infrastructure exposure calculation for each region and two-decade period. To effectively illustrate the range of flood predictions and to offer a vivid picture of uncertainty in the flood model outcomes, we use the minimum (Min), median and maximum (Max) scenarios selected by their “peak_SL_navd” values (peak sea level tide heights) from the table (e.g. **Table C 6**). In some cases when we want to describe more typical scenarios, particularly for individual operator infrastructures, we may use Median scenarios.

C.4.2 Calculating Exposure

We used the output raster datasets of predicted inundation depths for the Min, Median, and Max scenarios for each region and the bi-decadal period for overlay analysis with the TFS infrastructure. With the raster inundation layers, we first classified inundation depths into discrete groups. The overlay of the classified raster with infrastructure, for example, liquid product terminals, produced a table of operators, inundation depth classes, and areas of pipeline exposed to coastal flooding at various depths of inundation (**Table C 9**).

C.4.3 Flooding Exposure by Asset Operator and Geography

In terms of assets of interest, we focused on product pipelines, crude oil pipelines, refineries, and terminals in our detailed analysis.

C.4.3.1 Product Pipelines and Crude Oil Pipelines

In California, product pipelines are clustered in two geographic areas, Northern California (NorCal) around the San Francisco Bay Area and Sacramento-San Joaquin Delta, with one segment extending to Reno, NV; and Southern California (SoCal), around the Los Angeles area with segments extending to Nevada and Arizona (**Figure C 11**). We calculated inundated pipelines relative to assets in the northern or southern pipeline areas separately because two pipeline clusters did not connect. The two geographic areas had some similarities and some distinct inundation exposure characteristics according to our results.

When we charted product pipeline inundation exposure totals for each scenario (i.e. Min, Median or Max) over the two-decade periods between 2020 and 2100, the differences between the Min and Max scenarios in terms of total inundated pipelines, were similar in Northern and Southern California. For example, the Min-Max differences were relatively small in the near future for Northern California (e.g. 2020-2040) but diverged sharply in the later decades. For Southern California, the rate differences were similar even though inundation totals overall were significantly less than in Northern California (see **Figure C 19**).



Figure C 11. Product and crude-oil pipelines have different geographic footprints. Fuel product pipelines tend to cluster at refineries and radiate outwards (note that the two fuel product pipeline clusters do not connect) while crude oil pipelines tend to connect crude source to refinery locations.

Product pipelines were mainly exposed to flooding in the San Francisco Bay Area and Sacramento-San Joaquin Delta in the north, and in Long Beach Harbor Area in the south.

Exposed product pipeline length in the north was about twice the length of that in the south under the median scenario high sea level event from the 24 scenarios covering RCP 4.5 and 8.5 (Figure C 12 (a) and (b)). One northern operator, Kinder Morgan, Inc. (KM) has a pipeline system referred to as SFPP, which is the most exposed (Figure C 12 (a)), suffering approximately twice as much inundation as the sum of all the other SF Bay operators. Such

extensive exposure is because Kinder Morgan has very long pipelines along the Bay and Delta margins. The exposure is more distributed among southern operators, with five operators owning more than 65% of the exposed product pipelines (Figure C 12 (b)). The exposed pipeline is only a small percent (i.e. about 6% on average over the five periods) of the entire SFPP pipeline system in the north (Figure C 12 (c)), whereas many small operators in the south have much larger proportions of their pipelines exposed (e.g. Pennzoil: 68.12% on average over the five periods, Petro-Diamond: 29.86 %, Ultramar Inc.: 39.72%, Vopak: 28.54%, Figure C 12 (d)).

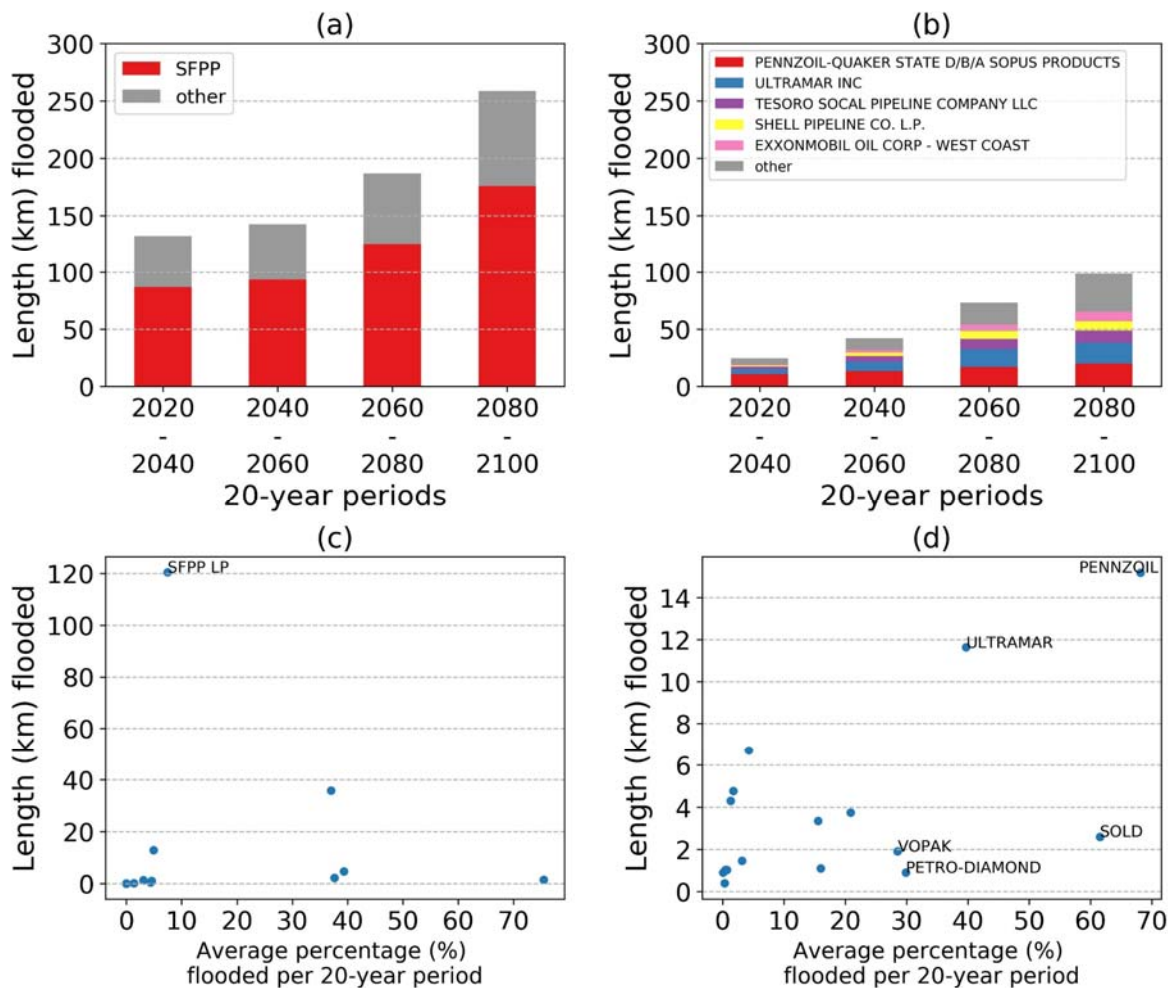

Figure C 12. Patterns of product pipeline's exposure to coastal flooding, divided by geographic regions and operators. (a) and (b) contrasted the most exposed operators to other exposed operators in Northern California and Southern California respectively. (c) and (d) highlighted the relationship between the absolute exposure (i.e. length of pipeline exposed) and relative exposure (i.e. % pipeline exposed) by each operator in Northern California and Southern California respectively.

Unlike the disjoint product pipeline systems, California crude oil pipelines are an integrated statewide system, thus our analysis considered crude oil pipelines as a statewide and not regional system (Figure C 11). However, there were distinct differences in inundation exposure between Northern California and Southern California crude pipeline operators. In both regions,

the largest operators in terms of total kilometers of assets had the longest length of assets exposed, but this exposure represented a small percentage of total assets while small operators had higher percentages of asset exposed. However, regionally considered, crude oil pipelines in the south had much more exposure than that of Northern California pipelines (e.g. 60 km versus 10 km, under the median scenario during the 2040-2060 period **Table C 7**). In addition, in LA, the two largest players were affected (i.e. Crimson and Phillips66). **Figure C 13** and **Figure C 14** show the differing exposure of crude pipeline operators in the LA/Long Beach Harbor Area and SF Bay Area Martinez region.

Table C 7. Crude pipeline exposure under the median scenario high sea level event, 2040-2060

Region		Operator	Pipelines exposed (km)	% of the total crude pipelines
North		Chevron Pipe Line Co.	3.1	>0.1
		Tesoro Logistics Golden Eagle	3.8	59
		Shell Pipeline Co.	1.8	>0.1
		Valero Ref. Co.	0.8	5
South		Crimson Pipeline	15.7	2
		Paramount Petroleum	9.1	4
		Phillips66 Pipeline	6.2	1
		Tesoro SOCAL Pipeline	1.4	4
		Chemoil Terminals	5.6	12
		Plains Marketing	4.8	2

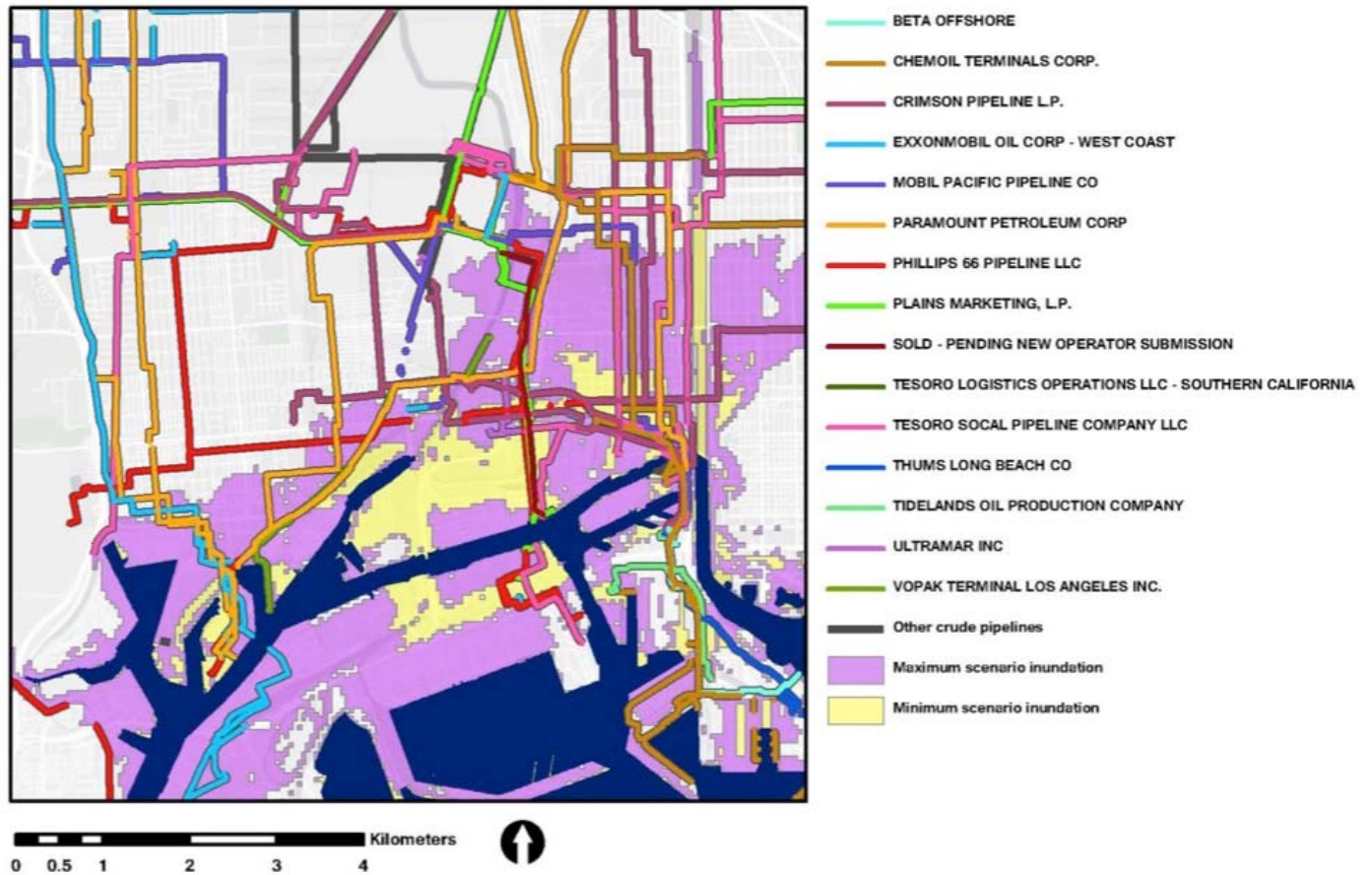

Figure C 13. Exposed crude oil pipeline operators at LA/Long Beach Harbor (2100 Max and Min flooding scenarios).

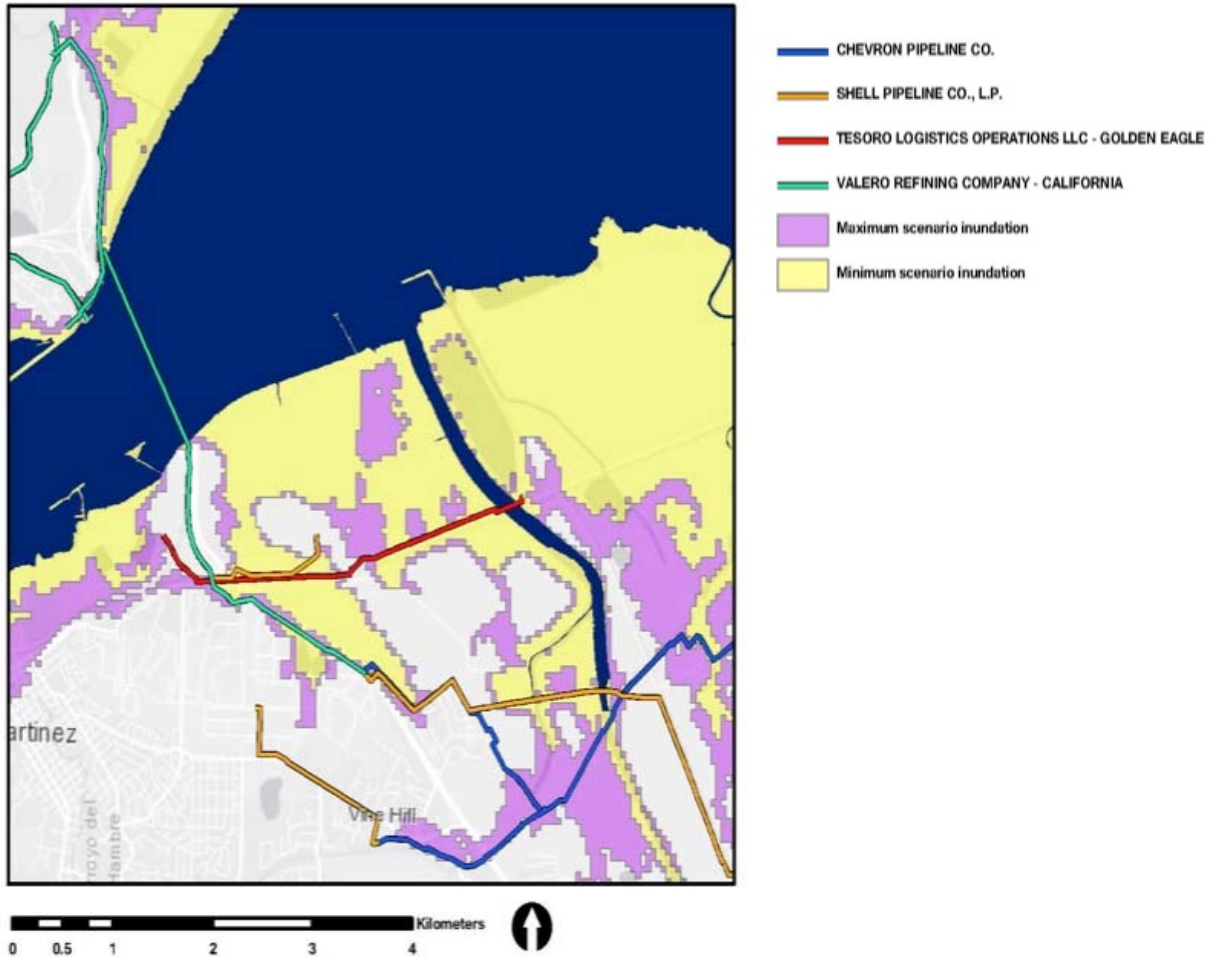

Figure C 14. Exposed crude oil pipeline operators at Martinez, SF Bay Area region (2100 Max and Min flooding scenarios).

C.4.3.2 Refineries

Refineries are located near sources of crude oil: crude from wells (e.g., in Bakersfield which is not exposed to coastal flooding) or from ocean-going tankers, as is the case along the shores of the San Francisco Bay and Delta and in the harbor areas of southern Los Angeles. In the north and south, from an inundation perspective, refinery exposure was dominated by one refinery in each locale. In the north, Chevron-Richmond was the most affected refinery with the Martinez facilities becoming exposed only in the more extreme scenarios. In Southern California, the Valero Energy-Wilmington was the most exposed, with other refineries only marginally exposed in the later, maximum scenarios.

It should be noted that our analysis was a tabulation of the flooded area of refinery facility footprints only. We made no attempt to identify affected infrastructure facilities. This distinction is particularly important as in the SF Bay area, where refinery areas tend to be existing wetlands, while in the Los Angeles Harbor region refineries are in more built-up areas.

Table C 8 summarizes refinery footprint exposure. In the north, approximately 14-18% of the Chevron Richmond refinery area could be inundated by 2040, and 20-57% by 2100. In

comparison, all other Bay Area Region refineries were far less exposed in total, 1-2% by 2040 but only by 2100 did the Martinez refineries, particularly Shell and Tesoro, become exposed depending upon scenario (4-21% by 2100). In Southern California, in the 2020-2040 scenarios, 14 to 18% of the Valero Energy Corp Wilmington refinery footprint was exposed and no other refinery was impacted. By the year 2100, 77 to 100% of Valero was exposed and under the Max scenario, Tesoro Wilmington had 42% of its facility area exposed (**Table C 8** and **Figure C 15**).

Table C 8. Refinery exposure under the maximum and minimum scenario high sea level event, 2020-2040 and 2080-2100.

SF Bay Region	Min Scenario		Max scenario	
	Hectares	%	Hectares	%
2020-2040				
Chevron, Richmond	175.6	14.3%	222.6	18.1%
Andeavor, Martinez	0.6	0.4%	2.2	1.3%
All others	10.2	1.0%	22.3	2.1%
2080-2100				
Chevron, Richmond	240.4	19.5%	697.1	56.6%
Andeavor, Martinez	3.9	2.2%	117.1	68.2%
All others	51.2	4.9%	204.0	17.1%
LA Region				
2020-2040				
Valero, Wilmington	33.5	40%	47.2	56%
2080-2100				
Valero, Wilmington	64.6	77%	83.9	100%
Andeavor, Wilmington	0.0	0.0%	97.1	42%

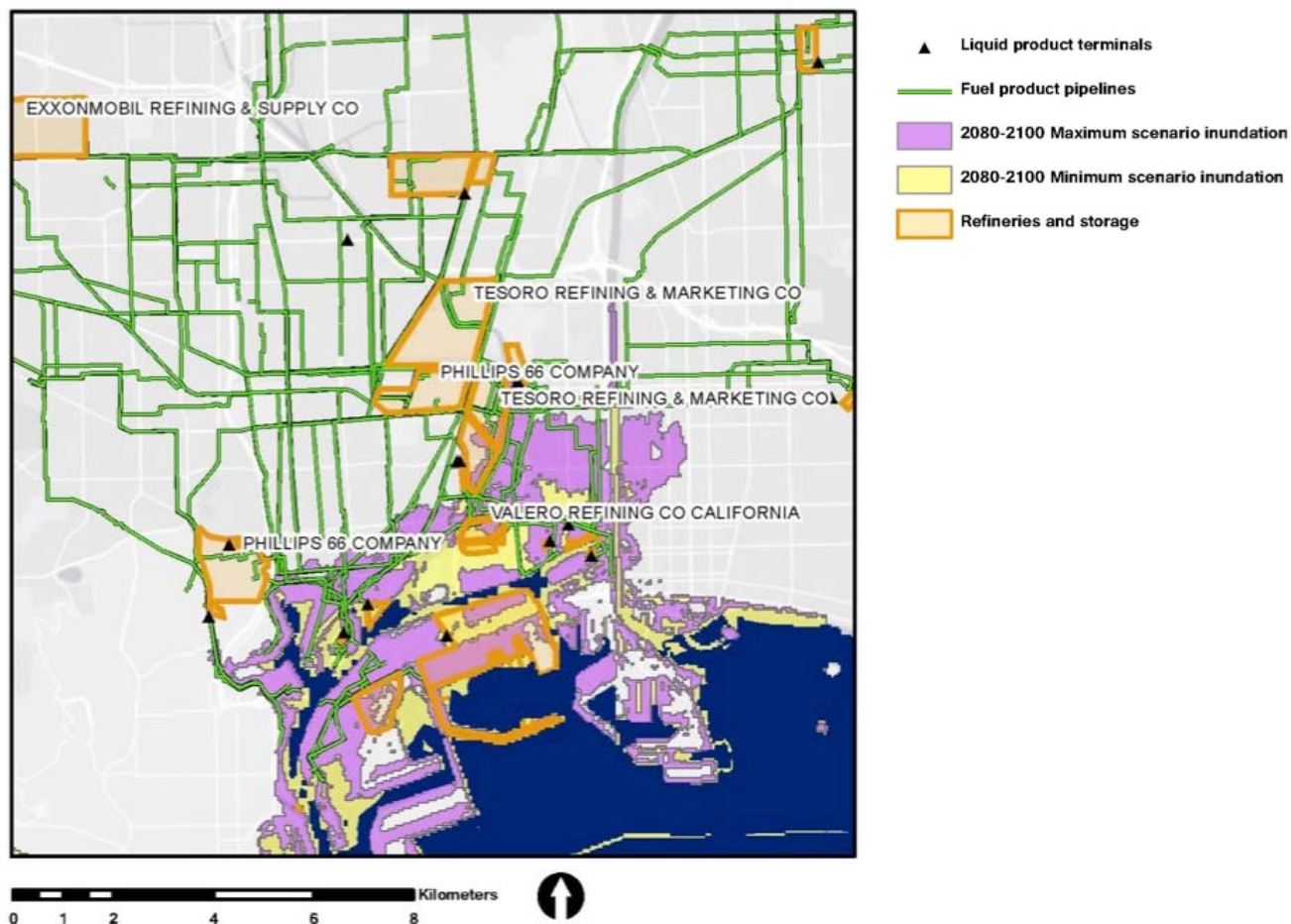

Figure C 15. Southern California Refineries in the harbor area where coastal flooding can occur.

C.4.3.3 Terminals

As explained in Appendix A, terminals can be any facility where there is a transfer of oil or fuel products from one transport system to another, often with local onsite storage. Some notable facilities illustrating the variation of terminal types:

- Tesoro (now Andeavor) Long Beach Terminal 1/Berth 121, this single marine terminal offloads crude from marine tankers and supplies 80% (~500,000 barrels / day) of the crude to Southern California (Figure C 16);
- BNSF Richmond, a rail terminal for ethanol and other vital inputs;
- Kinder Morgan, Inc. Concord Station, primarily a pumping station for movement of fuel products in pipelines;
- Aircraft Service International Inc., which is a jet fuel distribution system within the San Francisco International Airport (SFO).

In Northern California, our results showed that there were many relatively small potentially exposed terminals clustered around Richmond and Martinez and one airport serving facility,

SFPP LP in Brisbane serving SFO. Within the airports, there are fuel distribution systems, Aircraft Service International (at SFO) and Swissport Fueling Inc. (at Oakland International Airport). In Southern California, as with other facilities, the LA/Long Beach Harbor area dominated terminal inundation exposure.

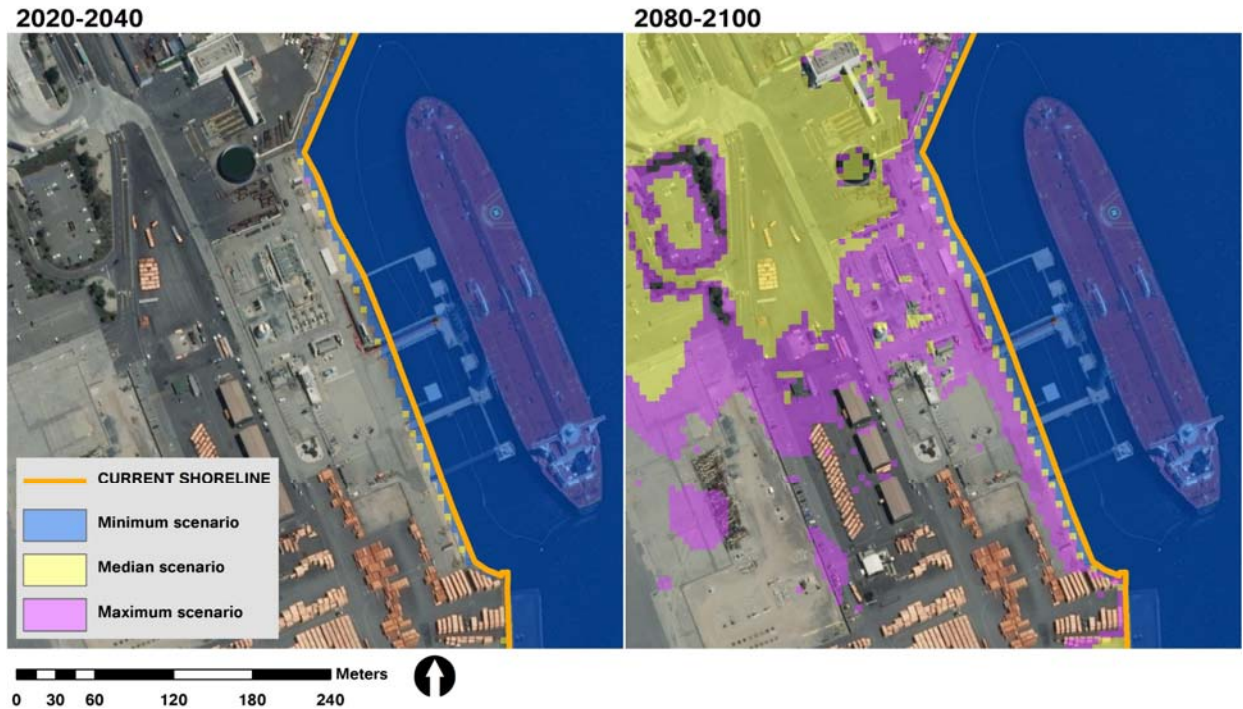

Figure C 16. The Andeavor Long Beach Terminal 1/Berth 121

We analyzed terminal exposure but should note that while the Northern California terminal data was sufficient for a quantitative analysis of inundation exposure, the Southern terminal data was not. For the entire state, we had point (centroid) terminal location data, but when we used point data to identify inundated parcels (e.g., the 2040-2060 Median scenario flood footprint), we got 10 inundated terminals out of 100 statewide terminals. Such centroid inundation was a biased estimate of inundation exposure as typically something like the center of an area must be flooded before it was counted as exposed to inundation.

In the north, with the exception of Plains Products, Martinez area terminals were only exposed in the maximum scenario and the Kinder Morgan Concord Station was not exposed to coastal flooding at all (**Figure C 17(a)**). A similar pattern follows at Richmond (**Figure C 17(b)**); in

Table C 9 the exposure of the Richmond Harbor facilities is overstated due to shoreline edge effects in the 50m raster). At Brisbane, the SFPP LP facility (Kinder Morgan, Inc.) is only exposed in the maximum 2100 scenario (**Figure C 17(c)**).

Table C 9. Coastal flooding exposure for Northern California liquid product terminals under the 2040-2060 Median scenario. Note that Central California (Sacramento, Stockton) and North Coast (Eureka) terminals are affected. The relatively coarse 50m raster inundation data interacting with the small size of many terminals and shoreline locations limits the accuracy of these results.

Operator	Area (m ²) by inundation depth (m)														Total area (m ²)	Inundated (m ²)	Inundated (%)
	Existing water	none	0-0.5	0.5-1	1-1.5	1.5-2	2-3	3-4	4-5	5-6	6-7	7-8	8-9	>9			
PLAINS PRODUCTS TERMINALS LLC MARTINEZ	0	450487	48603	24013	24058	11446	0	0	0	0	0	0	0	0	558608	108121	19.36
IMTT - RICHMOND - CA RICHMOND	0	65393	26478	0	940	840	0	0	0	0	0	0	0	0	93651	28259	30.17
Kinder Morgan Liquids Terminals LLC	1239	72553	2046	0	0	2500	0	2500	2500	0	2500	291	5000	2500	93628	19837	21.19
BP LUBRICANTS USA INC RICHMOND	1937	5882	4822	1932	0	0	2494	0	0	0	128	0	1857	980	20032	12213	60.97
Phillips 66 PL - Richmond	798	128380	1506	1971	3909	0	0	1213	0	0	0	0	0	0	137777	8599	6.24
CHEVRON USA INC EUREKA CA	0	11806	42	1642	2500	3037	0	0	0	0	0	0	0	0	19027	7221	37.95
Tesoro Logistics Operations LLC *	0	1913628	5567	566	434	178	0	0	0	0	0	0	0	0	1920372	6744	0.35
NUSTAR ENERGY LP PITTSBURGH ASPHALT	0	74925	4919	63	0	0	0	0	0	0	0	0	0	0	79906	4981	6.23
TESORO LOGISTICS OPERATION S LLC STOCKTON	0	240440	1621	0	0	0	0	0	0	0	0	0	0	0	242061	1621	0.67
Shell Oil Products US - W Sacramento	0	23609	0	0	387	334	0	0	0	0	0	0	0	0	24330	721	2.96
CHEVRON USA INC MARTINEZ CA	0	550364	17	0	0	0	0	0	0	0	0	0	0	0	550381	17	0.00

* Includes a Southern California terminal

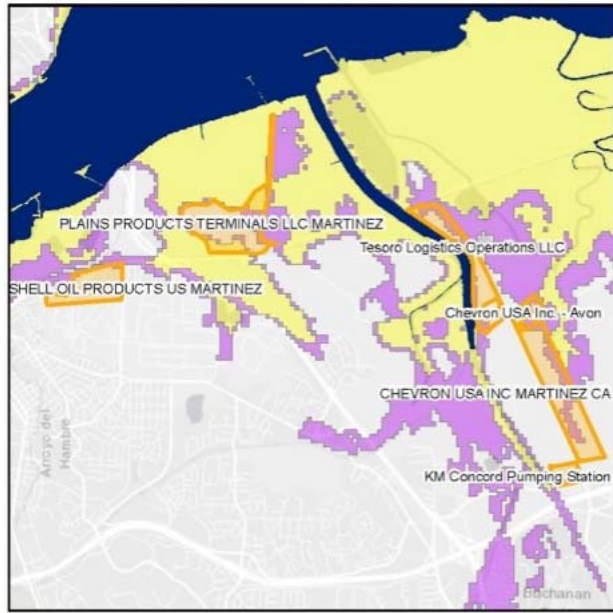

(a)

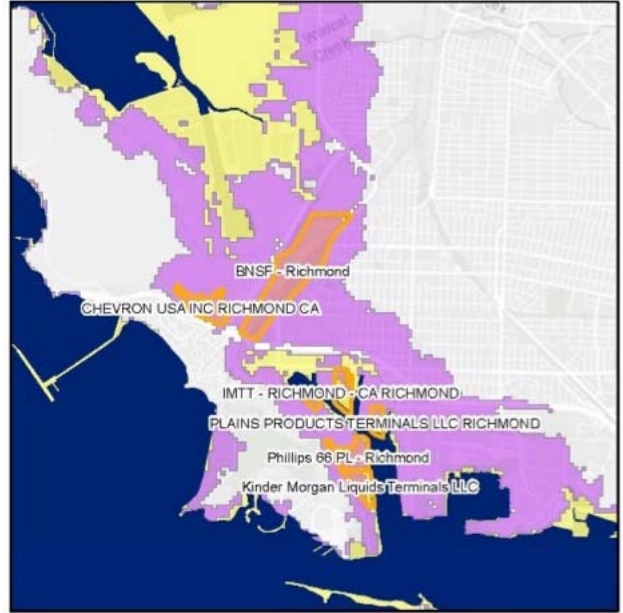

(b)

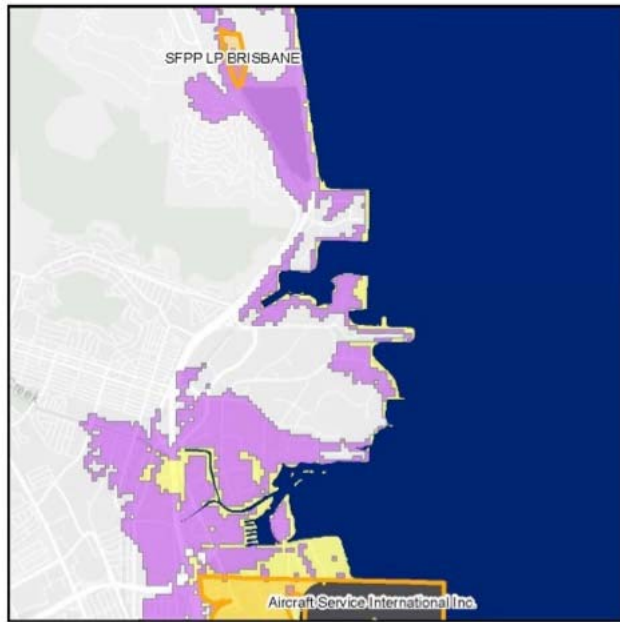

(c)

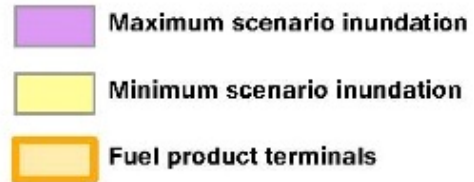

Figure C 17. Northern California liquid product terminals inundation under the 2080-2100 Min and Max scenarios. (a) Martinez area; (b) Richmond area; and (c) Brisbane area.

In the south, the Paktank, NuStar Energy, and Vopak terminals were exposed even at the minimum scenario 2100 levels (the year 2080-2100 minimum inundation was similar to 2040-2060 median scenario inundation). Terminal Island represents a complex situation as the whole island was exposed, but minimum scenario 2100 inundation (i.e., at a higher flooding potential) only occurred in the northwest area, the site of Vopak Terminal Long Beach and the NRG Long Beach Power facility (**Figure C 18**).

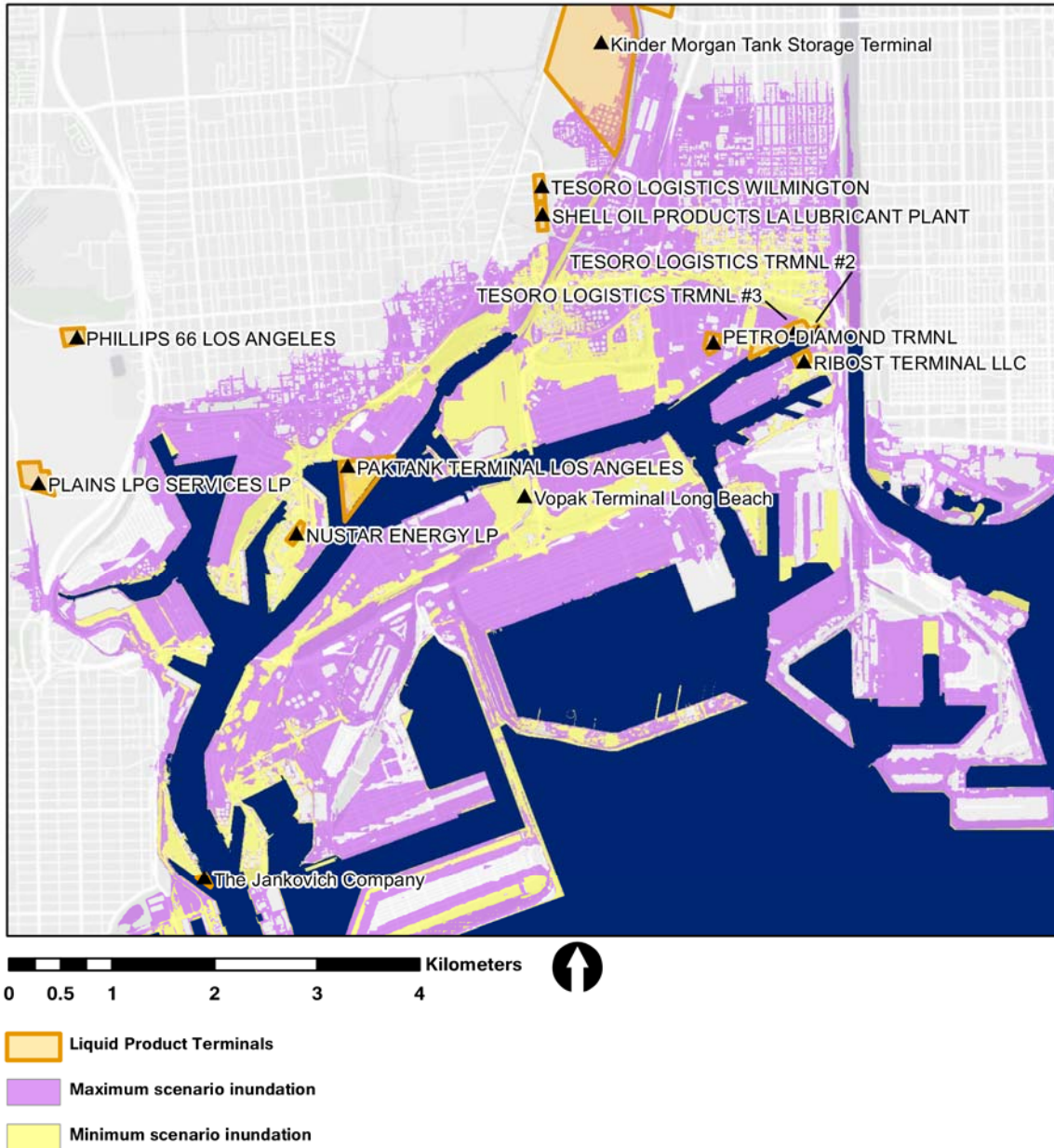

Figure C 18. Southern California Liquid Product Terminals LA/Long Beach Harbor under the 2080-2100 Min and Max scenarios. Please note, as described in Appendix A, section A.2.1.1, terminal definitions can vary, and many owners and operators have changed since these data were compiled.

C.4.4 Uncertainties

Due to a range of sea levels modeled in this study (Supplementary Table 1), TFS asset's exposure varied by the scenarios and such variation increased when the analysis moved towards 2100. This difference in potential future sea level demonstrated under the various scenarios was an indication of the uncertainty in future coastal flood prediction. When we summarized inundation totals for max. and min. scenarios over 20-year periods, the differences between the two scenarios in terms of total inundated product pipelines, were relatively small in the near future for Northern California in the 2020-2040 period but diverged sharply in the later periods. By 2020-2040, the difference was 27 km (17 miles), or 110 versus (vs.) 137 km (68 vs. 85 miles), between the min. and max. scenarios. By 2080-2100, the difference was about 204 km (127 miles), or 152 km vs. 356 km (94 vs. 221 miles), between min. and max. scenarios.

Figure C 19 illustrates the exposed product pipelines in Northern and Southern California under the Min, Median, and Max scenarios over the 20-year periods.

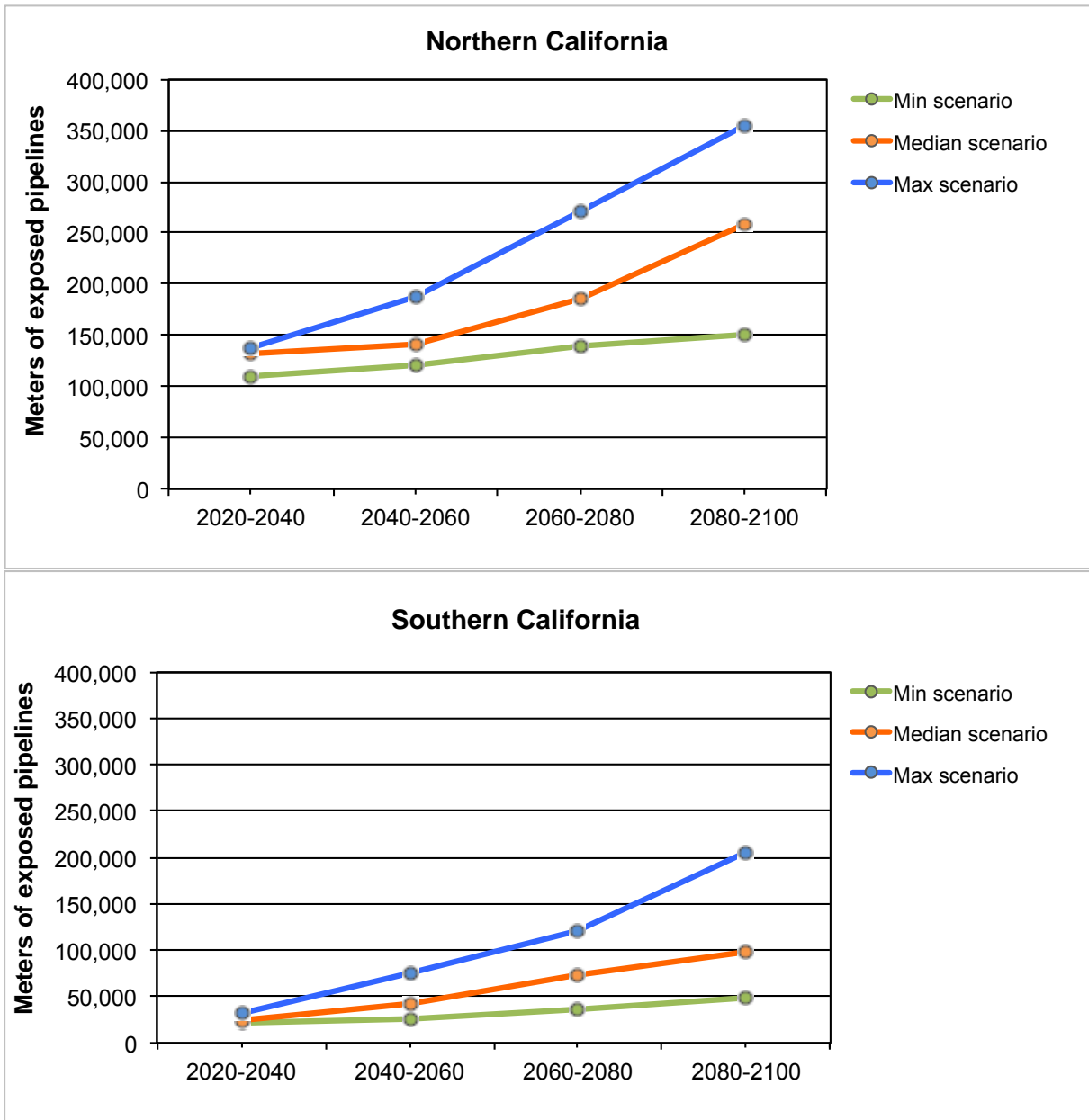

Figure C 19. Totals (meters) of exposed product pipelines for by Min, Median, and Max Climate Change Scenarios in (top) Northern California and (bottom) Southern California. Note that inundation lengths (X axis values) in Southern California are about half that of Northern California.

C.5 References

- Barnard, P. L., O'Reilly, B., van Ormondt, M., Elias, E., Ruggiero, P., Erikson, L. H., ... Adams, P. N. (2009). *The Framework of a Coastal Hazards Model- A Tool for Predicting the Impact of Severe Storms*. U. S. Geological Survey.
- Barnard, P. L., Ormondt, M. van, Erikson, L. H., Eshleman, J., Hapke, C., Ruggiero, P., ... Foxgrover, A. C. (2014). Development of the Coastal Storm Modeling System (CoSMoS) for predicting the impact of storms on high-energy, active-margin coasts. *Natural Hazards*, 74(2), 1095–1125. <https://doi.org/10.1007/s11069-014-1236-y>
- Biging, G. S., Radke, J. D., & Lee, J. H. (2012). *Impacts of predicted sea-level rise and extreme storm events on the transportation in the San Francisco Bay Region* (No. CEC - 500 - 2012 - 040). California Energy Commission.
- Cayan, D. R., Kalansky, J., Iacobellis, S., & Pierce, D. (2016). *Creating Probabilistic Sea Level Rise Projections to support the 4th California Climate Assessment* (No. 16- IEPR-04). California Energy Commission. Retrieved from http://docketpublic.energy.ca.gov/PublicDocuments/16-IEPR-04/TN211806_20160614T101823_Creating_Probabilistic_Sea_Leve_Rise_Projections.pdf
- Dasgupta, S., Laplante, B., Meisner, C., Wheeler, D., & Yan, J. (2008). The impact of sea level rise on developing countries: a comparative analysis. *Climatic Change*, 93(3–4), 379–388. <https://doi.org/10.1007/s10584-008-9499-5>
- DeConto, R. M., & Pollard, D. (2016). Contribution of Antarctica to past and future sea-level rise. *Nature*, 531(7596), 591–597. <https://doi.org/10.1038/nature17145>
- ESRI. (2016). ArcGIS Desktop (Version 10.4). ArcMap 10.4: ESRI.
- Homer, C., Dewitz, J., Yang, L., Jin, S., Danielson, P., Xian, G., ... Megown, K. (2015). Completion of the 2011 National Land Cover Database for the conterminous United States—representing a decade of land cover change information. *Photogrammetric Engineering & Remote Sensing*, 81(5), 345–354.
- Kopp, R. E., Horton, R. M., Little, C. M., Mitrovica, J. X., Oppenheimer, M., Rasmussen, D. J., ... Tebaldi, C. (2014). Probabilistic 21st and 22nd century sea-level projections at a global network of tide-gauge sites. *Earth's Future*, 2(8), 2014EF000239. <https://doi.org/10.1002/2014EF000239>
- Marcy, D., Herold, N., Waters, K., Brooks, W., Hadley, B., Pendleton, M., ... Ryan, S. (2011). *New mapping tool and techniques for visualizing Sea Level Rise and coastal flooding impacts*. NOAA Coastal Service Center.
- Natural Resource Conservation Service. (2017). *wbdhu12_a_us_september2017*. U.S. Department of Agriculture. Retrieved from <https://nrcs.app.box.com/v/huc/folder/39640323180>
- Pierce, D., Cayan, D. R., & Dehann, L. (2016). *Creating Climate projections to support the 4th California Climate Assessment* (No. 16- IEPR-04). California Energy Commission. Retrieved from http://www.energy.ca.gov/2016_energypolicy/documents/2016-06-21_workshop/2016-06-21_documents.php

- Poulter, B., & Halpin, P. N. (2008). Raster modelling of coastal flooding from sea - level rise. *International Journal of Geographical Information Science*, 22(2), 167 - 182. <https://doi.org/10.1080/13658810701371858>
- Radke, J. D., Biging, G. S., Schimidt-Poolman, M., Foster, H., Roe, E., Ju, Y., ... Reeves, I. (2014). *Assessment of Bay Area Gas Pipeline Vulnerability to Climate Change* (No. CEC-500-11-016). California Energy Commission.
- Soil Survey Staff. (n.d.). SSURGO Database. Web Soil Survey, Natural Resources Conservation Service, United States Department of Agriculture. Retrieved from <https://websoilsurvey.nrcs.usda.gov/>
- Stelling, G. S. (2012). Quadtree flood simulations with sub-grid digital elevation models. *Proceedings of the ICE - Water Management*, 165(10), 567-580. <https://doi.org/10.1680/wama.12.00018>
- Strauss, B. H., Ziemiński, R., Weiss, J. L., & Overpeck, J. T. (2012). Tidally adjusted estimates of topographic vulnerability to sea level rise and flooding for the contiguous United States. *Environmental Research Letters*, 7(1), 014033. <https://doi.org/10.1088/1748-9326/7/1/014033>
- USGS. (2014). National Land Cover Database (NLCD). Retrieved from <http://www.mrlc.gov/finddata.php>
- Vieux, B. E. (2001). Distributed Hydrologic Modeling Using GIS. In *Distributed Hydrologic Modeling Using GIS* (pp. 1-17). Springer, Dordrecht. https://doi.org/10.1007/978-94-015-9710-4_1

C.6 Appendix C Supplementary Tables

Supplementary Table 1 Summary statistics of peak sea levels at the ten locations during the five planning horizons. The peak sea levels are summarized separately for RCP 4.5 and 8.5.

Location	Planning horizon	RCP 4.5			RCP 8.5		
		min.	medium	max.	min.	medium	max.
Crescent City	2000 - 2020	3.03	3.15	3.24	3.05	3.13	3.18
	2020 - 2040	3.07	3.18	3.25	2.98	3.17	3.33
	2040 - 2060	3.07	3.32	3.49	3.08	3.51	3.93
	2060 - 2080	3.20	3.60	3.95	3.41	4.17	4.50
	2080 - 2100	3.29	4.02	4.50	3.92	5.04	5.57
Los Angeles	2000 - 2020	2.31	2.36	2.41	2.30	2.40	2.46
	2020 - 2040	2.28	2.41	2.51	2.30	2.43	2.55
	2040 - 2060	2.42	2.63	2.78	2.53	2.89	3.11
	2060 - 2080	2.61	3.09	3.53	2.81	3.49	3.91
	2080 - 2100	2.79	3.51	3.87	3.40	4.43	5.02
La Jolla	2000 - 2020	2.28	2.33	2.37	2.28	2.36	2.42
	2020 - 2040	2.27	2.42	2.53	2.32	2.46	2.57
	2040 - 2060	2.43	2.65	2.81	2.49	2.94	3.18
	2060 - 2080	2.67	3.16	3.43	2.89	3.55	3.95
	2080 - 2100	2.91	3.58	4.01	3.49	4.53	5.17
Monterey	2000 - 2020	2.32	2.58	2.66	2.43	2.47	2.51
	2020 - 2040	2.41	2.61	2.83	2.46	2.58	2.72
	2040 - 2060	2.56	2.75	2.93	2.55	2.92	3.25
	2060 - 2080	2.68	3.13	3.50	2.89	3.66	4.05
	2080 - 2100	2.90	3.66	4.05	3.53	4.61	5.17
Arena Cove	2000 - 2020	2.66	2.79	2.99	2.65	2.78	2.90
	2020 - 2040	2.61	2.87	3.10	2.76	2.90	3.16
	2040 - 2060	2.81	3.04	3.20	2.77	3.17	3.56
	2060 - 2080	2.79	3.35	3.60	3.18	3.86	4.21
	2080 - 2100	3.12	3.83	4.23	3.73	4.86	5.46
Point Reyes	2000 - 2020	2.50	2.70	2.90	2.55	2.63	2.71
	2020 - 2040	2.53	2.83	3.03	2.64	2.77	2.90
	2040 - 2060	2.75	3.00	3.17	2.78	3.13	3.56
	2060 - 2080	2.86	3.32	3.71	3.08	3.88	4.20
	2080 - 2100	3.12	3.86	4.26	3.73	4.84	5.52
Santa Barbara	2000 - 2020	2.28	2.39	2.46	2.25	2.33	2.46
	2020 - 2040	2.26	2.49	2.66	2.34	2.44	2.54
	2040 - 2060	2.38	2.68	2.84	2.46	2.88	3.09
	2060 - 2080	2.53	3.01	3.33	2.78	3.48	3.86
	2080 - 2100	2.79	3.48	3.88	3.34	4.42	5.04
Port Chicago	2000 - 2020	2.36	2.43	2.63	2.22	2.29	2.32
	2020 - 2040	2.25	2.45	2.55	2.31	2.41	2.49
	2040 - 2060	2.37	2.53	2.72	2.33	2.79	3.15
	2060 - 2080	2.57	2.98	3.30	2.73	3.58	4.03
	2080 - 2100	2.81	3.74	4.30	3.47	4.71	5.39
San Francisco	2000 - 2020	2.61	2.79	2.94	2.49	2.60	2.63
	2020 - 2040	2.53	2.81	2.98	2.66	2.78	2.88
	2040 - 2060	2.71	2.90	3.10	2.68	3.11	3.50
	2060 - 2080	2.90	3.29	3.57	3.11	3.82	4.17
	2080 - 2100	3.08	3.90	4.40	3.78	4.86	5.50
Port San Luis	2000 - 2020	2.30	2.39	2.57	2.30	2.38	2.46
	2020 - 2040	2.34	2.60	2.77	2.40	2.53	2.61
	2040 - 2060	2.47	2.66	2.84	2.46	2.87	3.22
	2060 - 2080	2.61	3.11	3.39	2.81	3.55	3.90
	2080 - 2100	2.81	3.57	4.05	3.40	4.46	5.01

Supplementary Table 2 Amount of each TFS asset type exposed to each coastal flooding exposure class¹ during the median scenario event² in the 24 high sea level events derived from the two emission scenarios (RCP 4.5 and 8.5), four GCMs (a warm/dry, a cool/wet, an average, and a complementary model), and three probabilistic SLR values (the 50th, 90th, and 99.9th percentile). Periods of interest to TFS stakeholders are included.

Assessment Period	2000-2020					
Flooding Exposure	None	Low	Moderate	High	Very High	Extreme
Refineries (km ²)	48.31	0.85	0.75	0.41	0.17	0.21
Terminals (km ²)	67.58	2.49	2.12	1.05	0.37	0.66
Docks (count)	198	2	1	0	1	11
Airports (count)	208	1	0	1	2	1
Gas Stations (count)	13437	29	17	10	3	1
Oil fields (km ²)	3413.76	19.90	15.78	14.72	12.48	93.11
Pipelines (km)	11632.50	69.95	27.02	21.21	19.46	41.80
Roadways (km)	23904.40	45.79	33.93	17.73	16.42	50.74
Railways (km)	7349.64	31.89	19.25	12.66	7.76	12.11
Assessment Period	2020-2040					
Flooding Exposure	None	Low	Moderate	High	Very High	Extreme
Refineries (km ²)	47.92	0.90	0.83	0.57	0.20	0.26
Terminals (km ²)	66.86	2.53	2.39	1.21	0.58	0.70
Docks (count)	196	4	1	0	1	11
Airports (count)	207	2	0	1	1	2
Gas Stations (count)	13432	28	16	17	3	1
Oil fields (km ²)	3402.16	22.86	18.27	14.41	12.12	99.93
Pipelines (km)	11608.60	73.24	36.68	26.53	20.01	46.84
Roadways (km)	23888.80	47.67	38.35	20.81	17.31	56.02
Railways (km)	7338.78	32.37	21.18	17.16	9.45	14.37
Assessment Period	2040-2060					
Flooding Exposure	None	Low	Moderate	High	Very High	Extreme
Refineries (km ²)	47.43	0.97	0.89	0.70	0.36	0.33
Terminals (km ²)	65.90	2.42	2.54	1.69	0.89	0.82
Docks (count)	192	7	1	1	0	12
Airports (count)	207	2	0	0	2	2
Gas Stations (count)	13409	39	23	16	6	4
Oil fields (km ²)	3382.45	23.87	21.58	17.83	13.87	110.15
Pipelines (km)	11555.00	97.53	52.76	27.33	22.74	56.58
Roadways (km)	23863.60	50.80	41.85	29.59	16.83	66.34
Railways (km)	7326.24	28.67	26.79	19.37	12.88	19.37
Assessment Period	2060-2080					
Flooding Exposure	None	Low	Moderate	High	Very High	Extreme
Refineries (km ²)	45.54	1.62	1.11	1.02	0.72	0.66
Terminals (km ²)	64.61	1.48	2.47	2.57	1.51	1.63
Docks (count)	182	10	7	1	1	12
Airports (count)	205	2	1	1	1	3
Gas Stations (count)	13357	48	44	22	18	8
Oil fields (km ²)	3363.13	25.15	23.88	20.61	15.48	121.52
Pipelines (km)	11440.30	108.71	97.16	53.25	28.09	84.41
Roadways (km)	23799.80	60.98	52.04	43.15	29.20	83.83
Railways (km)	7282.67	37.40	29.62	30.14	19.14	34.35
Assessment Period	2080-2100					
Flooding Exposure	None	Low	Moderate	High	Very High	Extreme
Refineries (km ²)	42.61	2.08	2.12	1.09	1.08	1.70
Terminals (km ²)	62.38	1.59	1.58	2.49	2.72	3.50
Docks (count)	167	16	7	9	1	13
Airports (count)	203	3	1	1	1	4
Gas Stations (count)	13229	94	60	56	29	29
Oil fields (km ²)	3323.20	20.48	24.64	26.28	22.88	152.29
Pipelines (km)	11305.30	118.07	106.55	94.72	57.55	129.75
Roadways (km)	23693.40	78.87	65.30	60.37	42.43	128.64
Railways (km)	7182.27	62.07	52.88	39.53	33.01	63.56

¹ Flooding exposure was classified by maximum flooding depth during the high sea level events: none (0 m (0 ft.) depth or existing water), low (0 m (0ft) < depth <= 0.5 m (1.64 ft.)), moderate (0.5 m (1.64 ft.) < depth <=1.0 m (3.28 ft.)), high (1.0 m (3.28 ft.) < depth <= 1.5 m (4.92 ft.)), very high (1.5 m (4.92 ft.) < depth <= 2.0 m (6.56 ft.)), and extreme (2.0 m (6.56 ft.) < depth).

² As there were two middlemost scenarios in even number of events, we used the middlemost one with higher peak sea level as the median.

Supplementary Table 3. Percentage of each TFS asset type exposed to each coastal flooding exposure class¹ during the median scenario event² in the 24 high sea level events derived from the two emission scenarios (RCP 4.5 and 8.5), four GCMs (a warm/dry, a cool/wet, an average, and a complementary model), and three probabilistic SLR values (the 50th, 90th, and 99.9th percentile). Periods of interest to TFS stakeholders are included.

Assessment Period	2000-2020					
Flooding Exposure	None	Low	Moderate	High	Very High	Extreme
Refineries (%)	95.31	1.67	1.47	0.80	0.33	0.41
Terminals (%)	91.00	3.36	2.86	1.41	0.49	0.89
Docks (%)	92.96	0.94	0.47	0.00	0.47	5.16
Airports (%)	97.65	0.47	0.00	0.47	0.94	0.47
Gas Stations (%)	99.56	0.21	0.13	0.07	0.02	0.01
Oil fields (%)	95.63	0.56	0.44	0.41	0.35	2.61
Pipelines (%)	98.48	0.59	0.23	0.18	0.16	0.35
Roadways (%)	99.32	0.19	0.14	0.07	0.07	0.21
Railways (%)	98.87	0.43	0.26	0.17	0.10	0.16
Assessment Period	2020-2040					
Flooding Exposure	None	Low	Moderate	High	Very High	Extreme
Refineries (%)	94.56	1.78	1.63	1.12	0.39	0.52
Terminals (%)	90.03	3.40	3.22	1.63	0.79	0.94
Docks (%)	92.02	1.88	0.47	0.00	0.47	5.16
Airports (%)	97.18	0.94	0.00	0.47	0.47	0.94
Gas Stations (%)	99.52	0.21	0.12	0.13	0.02	0.01
Oil fields (%)	99.95	0.01	0.01	0.00	0.00	0.03
Pipelines (%)	98.28	0.62	0.31	0.22	0.17	0.40
Roadways (%)	99.25	0.20	0.16	0.09	0.07	0.23
Railways (%)	98.73	0.44	0.28	0.23	0.13	0.19
Assessment Period	2040-2060					
Flooding Exposure	None	Low	Moderate	High	Very High	Extreme
Refineries (%)	93.58	1.92	1.75	1.37	0.71	0.66
Terminals (%)	88.74	3.26	3.42	2.27	1.20	1.11
Docks (%)	90.14	3.29	0.47	0.47	0.00	5.63
Airports (%)	97.18	0.94	0.00	0.00	0.94	0.94
Gas Stations (%)	99.35	0.29	0.17	0.12	0.04	0.03
Oil fields (%)	94.75	0.67	0.60	0.50	0.39	3.09
Pipelines (%)	97.82	0.83	0.45	0.23	0.19	0.48
Roadways (%)	99.15	0.21	0.17	0.12	0.07	0.28
Railways (%)	98.56	0.39	0.36	0.26	0.17	0.26
Assessment Period	2060-2080					
Flooding Exposure	None	Low	Moderate	High	Very High	Extreme
Refineries (%)	89.86	3.20	2.20	2.02	1.43	1.30
Terminals (%)	87.00	1.99	3.32	3.46	2.04	2.19
Docks (%)	85.45	4.69	3.29	0.47	0.47	5.63
Airports (%)	96.24	0.94	0.47	0.47	0.47	1.41
Gas Stations (%)	98.96	0.36	0.33	0.16	0.13	0.06
Oil fields (%)	94.21	0.70	0.67	0.58	0.43	3.40
Pipelines (%)	96.85	0.92	0.82	0.45	0.24	0.71
Roadways (%)	98.88	0.25	0.22	0.18	0.12	0.35
Railways (%)	97.97	0.50	0.40	0.41	0.26	0.46
Assessment Period	2080-2100					
Flooding Exposure	None	Low	Moderate	High	Very High	Extreme
Refineries (%)	84.08	4.10	4.19	2.15	2.14	3.35
Terminals (%)	84.00	2.15	2.13	3.35	3.67	4.71
Docks (%)	78.40	7.51	3.29	4.23	0.47	6.10
Airports (%)	95.31	1.41	0.47	0.47	0.47	1.88
Gas Stations (%)	98.01	0.70	0.44	0.41	0.21	0.21
Oil fields (%)	93.09	0.57	0.69	0.74	0.64	4.27
Pipelines (%)	95.71	1.00	0.90	0.80	0.49	1.10
Roadways (%)	98.44	0.33	0.27	0.25	0.18	0.53
Railways (%)	96.62	0.83	0.71	0.53	0.44	0.86

¹ Flooding exposure was classified by maximum flooding depth during the high sea level events: none ((0 m (0 ft.) depth or existing water), low (0 m (0ft) < depth <= 0.5 m (1.64 ft.)), moderate (0.5 m (1.64 ft.) < depth <=1.0 m (3.28 ft.)), high (1.0 m (3.28 ft.) < depth <= 1.5 m (4.92 ft.)), very high (1.5 m (4.92 ft.) < depth <= 2.0 m (6.56 ft.)), and extreme (2.0 m (6.56 ft.) < depth) .2 As there were two middlemost scenarios in even number of scenarios, we used the middlemost one with higher peak sea level as the median

APPENDIX D: Wildfire Data, Methods, and Results

The aim of this appendix is to describe the methodology that we used in this report for wildfire risk assessment at the State scale and at the local scale. We look at wildfire risk to assets of the Transportation Fuel Sector (TFS) with respect to time, space, and severity, in order to facilitate more risk-averse approaches for managing critical infrastructures important to society and the environment.

In this appendix, we evaluate historical trends, current wildfire assessments, and predictive models using future wildfire scenarios produced for California's Fourth Climate Change Assessment to better understand California's relationship with wildfire from 2018 until 2100. At the regional-scale, probabilistic wildfire forecasting was conducted to understand the threat of increasing frequencies of large wildfire events to the highly distributed TFS. At the asset-scale wildfire behavior modeling was utilized to understand the exposure of critical assets and TFS choke points to hazards that may exceed the capabilities of fire suppression resources. This multi-scale, multi-scenario wildfire assessment approach identifies ecoregions that are susceptible to increasing frequencies of large wildfire activity and quantifies the associated wildfire behavior for objects in these high-risk regions.

Findings:

- Based on climate and wildfire projections prepared for the California's Fourth Climate Assessment, the frequencies of large wildfire events are expected to increase and present significant threats to the TFS between 2018 and 2100.
- Planning and risk mitigation efforts should be coordinated to increase the resiliency of the interconnected, yet operationally independent, system.
- The advent of higher spatial resolution wildfire behavior modeling enables new insights into the expected fire behavior of catastrophic wildfires surrounding TFS assets. The clear benefits of high spatial resolution modeling are threefold: 1) an increased ability to represent buildings, roads, vegetation cover, and vegetation fuel breaks with greater precision and accuracy than coarser spatial resolution fire behavior modeling, 2) an enhanced capacity to inventory vegetation assemblages, assets, structures, roads, clearings, and natural fire breaks - this more detailed portrayal of the context in which an asset is located we are able to evaluate the fire behavior characteristics surrounding TFS assets for current and future wildfire scenarios, and 3) an improved ability to develop a targeted and data-driven wildfire risk mitigation strategy for individual TFS stakeholders.

This appendix has 3 sections:

- D.1. Wildfire Hazard, Threat and Risk Assessments: This section outlines the approaches and limitations of wildfire assessments, the uncertainties associated with predictive wildfire modeling, and our multi-scale, multi-scenario approach.
- D.2. Analysis of Historical, Near, Intermediate, and Long-Term Trends in CA Wildfire: This section analyzes wildfire hazard and threat assessments that have been produced

and/or approved by state and federal agencies responsible for managing wildfire and its impacts on California.

- D.3. High Resolution Wildfire Behavior Modeling: In this section the data sources, methodologies, benefits, limitations, and fidelity of our 5-m (16.4-ft) wildfire behavior modeling results are discussed.
- Details on the comparison of our modeling efforts to the post-devastation state of the 2016 Tubbs Fire can be found within section D.3.9.

D.1 Wildfire Hazard, Threat, and Risk Assessments

D.1.1 Introduction to Modeling Wildfire for Hazard, Threat, and Risk Assessments

Wildfire models produce important information for hazard, threat, and risk analyses when assessing potential exposure of an asset to this destructive natural phenomenon. There are many different approaches to modeling wildfire. Process-based models rely upon systems of reality-approximating equations to simulate time and space-variant rates of burn area perimeter expansion or other physical characteristics of combustion, including flame length and reaction intensity. Probabilistic and statistical wildfire models that rely upon historical observations can be used to predict when and where wildfires of specified sizes or severities are most likely to occur. It is important to note that these forecasting models should be used with caution given that they will be biased toward the periods from which the data used in their construction was collected. Moreover, wildfire modeling results developed from past observation can become unreliable when future conditions deviate from those presented during the historical period. When past conditions do match those of present or future prediction periods, statistical wildfire models can be used with greater confidence to describe patterns in wildfire likelihood, frequency, magnitude, or severity.

Wildfire threat assessments do not attempt to measure the effects of one or more wildfire events during the modeling period upon a particular area. Instead, the objectives of wildfire risk assessments are to forecast the likelihood of events, to describe expected behaviors (e.g. intensity). These insights can be applied to post hoc analyses of the direct and indirect effects to society and the environment (e.g., the loss of vegetation biomass, the creation of hydrophobic soils that increase runoff, the destruction of infrastructure, human death).

D.1.2 Modeling Uncertain Wildfire Futures

Most of the environmental controls on wildfire (e.g. flammable vegetation presence/absence, wind, temperature, atmospheric water content, etc.) are time and space variant. The magnitudes and directions of change, as well as patterns in these characteristics of change, can be quantitatively investigated using conditional burn probability modeling. An example of this approach to forecasting wildfire events is highlighted in Collins, Stephens, Roller, & Battles (2011).

Historically, California's Mediterranean climate has typically limited manifestations of extreme fire weather conditions to only the warmest and driest months of any given year. For most of the State, wildland fire season frequently begins during the late spring months and ends when the first substantial precipitation arrives in late fall or early winter. In recent years, large and catastrophic wildfires have been burning with increasing regularity during what have historically been months falling outside of the California fire season. Observed shifts in wildfire frequency and timing have largely been attributed to changes in climate and amounts of

flammable materials present in wildland systems. In turn, this recent trend toward a year-round wildfire season has led to increased suppression costs and economic losses.

Agencies responsible for managing wildfire events or dealing with the financial impacts have felt the burden of a longer fire season and wonder if recently observed changes in yearly wildfire patterns are going to become the status-quo moving forward. In search of answers, many have turned to forecasts generated from probabilistic and statistical models capable of incorporating long-term trends in climate, weather, population sizes and distributions, as well as changes in land use and land cover -- all of which are considered to be first or second order drivers of wildfire patterns, into estimations of what the future holds.

Event attribution methods can be used to better understand the severity associated with anticipated events. At present, the science of event attribution as it relates to wildfire faces a daunting challenge: there still exists a profound lack of long-term time-series datasets that can be used to calibrate and parameterize wildfire forecasting models (National Academies of Sciences, Engineering, and Medicine, 2016). While the accuracy and amount of detail included in descriptions of wildfire and local weather conditions have improved greatly during this century, significant sampling problems still exist and long-term oscillations in wildfire trends may not be well captured in wildfire projections due to deficiencies in the historical data that underpins them or due to climate shifts dissimilar from previous periods of observed fire history.

D.1.3 Overview of Multi-Scale Approach to Assessing Wildfire Hazards and Threats

Wildfires are hazardous events that endanger, and are expected to continue to endanger, individuals, organizations, and assets located in California and to release pollutants into that atmosphere which may affect neighboring States. As the amount of wildland-urban interface expands, and undeveloped areas become more exposed to human populations, the chances of a catastrophic wildfire taking place are increasing at the State level. When assessing changing risk to TFS infrastructure, a multiscale approach is especially useful. Broad changes in wildfire frequency and location will affect the relative importance and threat of this natural hazard, but do not necessarily imply asset hazard. A higher resolution perspective is required to assess specific threats to assets. Our team has analyzed the following sources of information:

- Historical trends in wildfire throughout California;
- Spatially explicit wildfire threat and hazard model outputs produced by state and federal agencies;
- Wildfire futures forecasted at regional scales; and
- Estimates of potential wildfire behavior produced by models used to shed light on how existing vegetation will burn at specific sites under extreme wildfire weather conditions.

Information and analytical methods incorporated into Appendix D can be used to support those working to assess the degree to which objects, populations, and systems are vulnerable to the effects of wildfire.

Technical terminology and phrases that have been abbreviated as acronyms throughout the remaining sections of Appendix D are listed in the acronym table at the end of this appendix; which has been included as a reference for readers.

D.2 Analysis of Historical, Near, Intermediate, and Long-Term Trends in California Wildfire

This section establishes the historical relationship of California's wildfire patterns needed to assess near, intermediate, and long-term estimates of wildfire futures. Particular attention will be paid to analyzing wildfire hazard and threat assessments that have been produced and/or approved by state and federal agencies responsible for managing wildfire and its impact on California. A wildfire futures dataset produced for California's Fourth Climate Change Assessment (Westerling, forthcoming) has been examined and distilled by our group in an effort to provide insights into the manner in which wildfire patterns are expected to trend over the remainder of the current century.

D.2.1 Introduction to California Wildfire History

Much of California has experienced wildfire in the past and will continue to endure destructive wildfires. Since the Mid-Holocene epoch, indigenous peoples of California set fires to produce landscape conditions that favored their survival. Prior to wildfires set by Native Americans, lightning storms were the primary source of ignition in the region. The impacts of wildfire during times that pre-date the arrival of Europeans and Euro-Americans created and maintained many fire-adapted ecosystems found in the State today. This fact supports a very inconvenient truth – wildfires are at home in California.

Wildland fires threaten valuable social and cultural assets. Since the beginning of the 20th Century, wildfire events have been actively suppressed in efforts to protect human life and property from harm. The exclusion of wildfire as a natural, restorative process capable of reducing fuel loads before they become excessively hazardous has curated a situation where many areas of California have not burned in over a century, despite experiencing wildfire events every few decades prior to the arrival of peoples non-indigenous to the region. In some parts of the State, fire exclusion has allowed the buildup of flammable biomass (fuel loads) to reach levels that were once rare when wildfires occurred with more frequency. Collins et al. (2009) observed that the quantity of flammable material accumulated on a site and the time since last fire at that site are correlated. The increased amount of dead and live woody material in these regions has exacerbated the hazards posed to ecosystems, to communities, and to infrastructure by the physical characteristics of wildfires burning with greater intensities. Further, the biomass accumulation has contributed to greater heat and greenhouse gas emissions over time than shallower fuel beds (less combustible material). The build-up of fuels over time is especially pronounced in many of the State's forested areas.

The removal of wildfire from California's forests has also led to the proliferation of stand structures that are highly susceptible to crown fire. The potential for crown fire has increased in many areas where wildfire-induced mortality has not occurred, and tree densities have risen in many fire-prone regions of the State. The accumulation of coarse woody debris over time now provides a great deal of horizontal continuity between upper forest strata and routes along which wildfire can propagate and spread from ground to crown. Crown fires² are an especially

²The term *crown fire* is used by Scott & Reinhardt (2001) in reference to both true crown fires (referring to burning individual tree crowns, also called torching or passive crown fire) and canopy fires (referring to fires that burn the whole forest canopy as a single entity, which include active, continuous, and independent crown fires).

hazardous form of wildfire from an emergency response perspective because these events are difficult, if not impossible, for ground-based firefighting resources to control through direct attack. Burning embers carried away from flaming tree crowns by wind have the potential to hasten the rate of perimeter expansion through the establishment of spot fires and present challenges to those attempting to prevent a wildfire from growing in size.

Historically, many of California's temperate forests experienced frequent low to medium severity fires, whereas much of the State's shrublands are thought to have faced infrequent high-severity fires. These relationships between severity and frequency were inverted when humans arrived in the ignition-limited shrublands and extinguished all new starts. Today, many areas that were once dominated by low-severity fires are experiencing more severe instances of wildfire (State Board of Forestry and Fire Protection, 2016).

D.2.2 California Wildfire Frequency, Size, and Severity Trends

Multiple wildfire frequency trends can be found within California. Wildfire frequency is a time-related metric used to describe local patterns in wildfire. Wildfire rotation lengths and fire return intervals are the most common descriptors of wildfire frequency. Wildfire rotation lengths are defined as the number of years required to burn an area equal to the size of the area for which the rotation length is being estimated. To illustrate this calculation, take the example of a situation where it has been determined from a wildfire perimeter history that an area spanning 5,000 acres (7.8 square miles) in size had an average of 100 acres (0.16 square miles) burn in wildfire events per year. The calculated fire rotation for this area based on the historical fire record would thus be 50 years. Fire return intervals on the other hand are estimates of the time that elapses between two successive fires within an evaluated area. This quantitative descriptor of local wildfire frequency is the mean fire-free interval, calculated as the arithmetic average of all wildfire intervals observed within a given area and period. Fire frequency is the reciprocal of the mean fire-free interval and yields the number of fires per unit time for a given area.

Once rotation lengths and mean fire return intervals have been determined, sub-regions of larger areas can be categorized based on differences in relative expected frequency of wildfire. Cal FIRE FRAP maintains a fire rotation class database (**Figure D 1**), which reveals trends in wildfire return intervals during the modern era. Wildfire return intervals are shortest in coastal regions of Central and Southern California as well as in areas east of Redding relative to the rest of the State. Wildfires occur with lower frequency throughout much of the Sierra Nevada and southeastern portions of California. Under the FRAP Historical Fire Rotation Class (HFRC) system, areas of California that have burned once every 300 years on average were classified by FRAP as having moderate frequency wildfire, while areas that burned once every one hundred years or less were classified as having very high wildfire frequencies. Historical wildfire categorizations were not determined for areas outside of the jurisdiction of State or Federal fire protection agencies or in areas having barren or developed (urban) land cover classifications (California Department of Forestry and Fire Protection Fire and Resource Assessment Program, 2003).

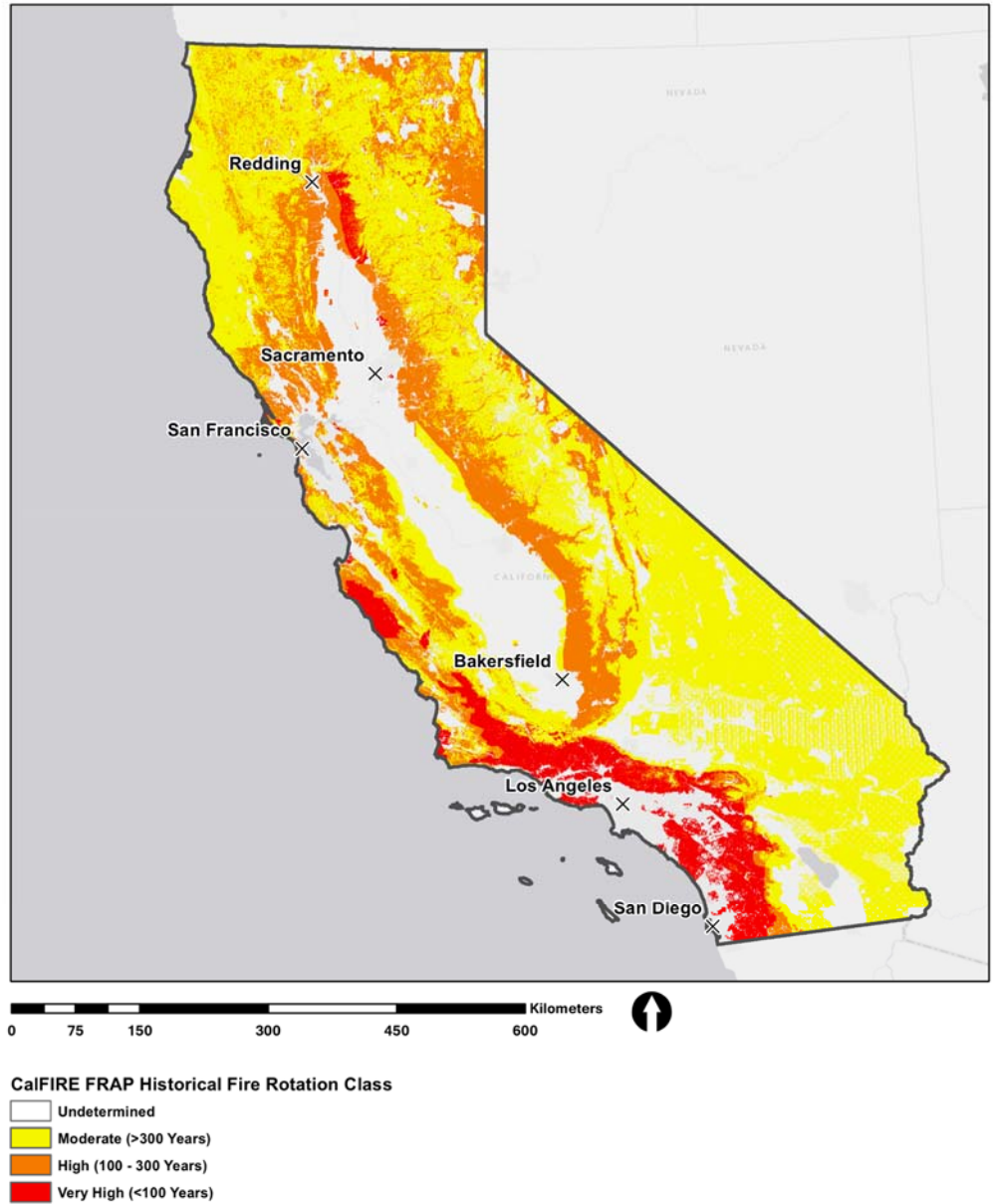

Figure D 1. Historical Fire Rotation Class (HFRC) categorizations for areas in California. Darker shades of red indicate more frequent wildfire than would be expected in areas covered by lighter shades of yellow or orange. Rotations represent modern era (20th-21st century) average fire-free intervals.

Trends in wildfire size across time and space can be investigated by analyzing geospatial datasets maintained by government agencies responsible for the management and documentation of wildfire incidents. These empirical datasets describe multiple attributes of wildfire events that have occurred in the State’s past including size, location, and date. An extensive burn perimeter database maintained by California’s wildfire management agency, CAL FIRE, Fire Resource and Assessment Program (FRAP) can be used to evaluate local and statewide historical trends in wildfire. **Figure D 2** maps out the spatial extent of each wildfire found in the FRAP database, which houses records for 19,483 fires that burned between 1898 and 2016. Large fires, such as the Biscuit Fire (500K acres, 2002), Rim Fire (250K acres, 2013), or

Soberanes Fire (300K acres, 2016) are well documented within the dataset as well as smaller wildfires and prescribed fires that have burned in the State. The Fire Program Analysis Fire Occurrence Database (FPA FOD) can be useful when assessing modern-era wildfire frequencies for areas located within context of the entire United States. The 1.88-million wildfire records included in this spatial database were sourced from federal, state, and local fire organizations reporting wildfires between 1992 and 2015 (Short, 2017). Another federally maintained dataset, Monitoring Trends in Burn Severity (MTBS), can be of great use when assessing severity, frequency, and size patterns for large wildfires (>1000 acres) that occurred between 1984 and 2015.

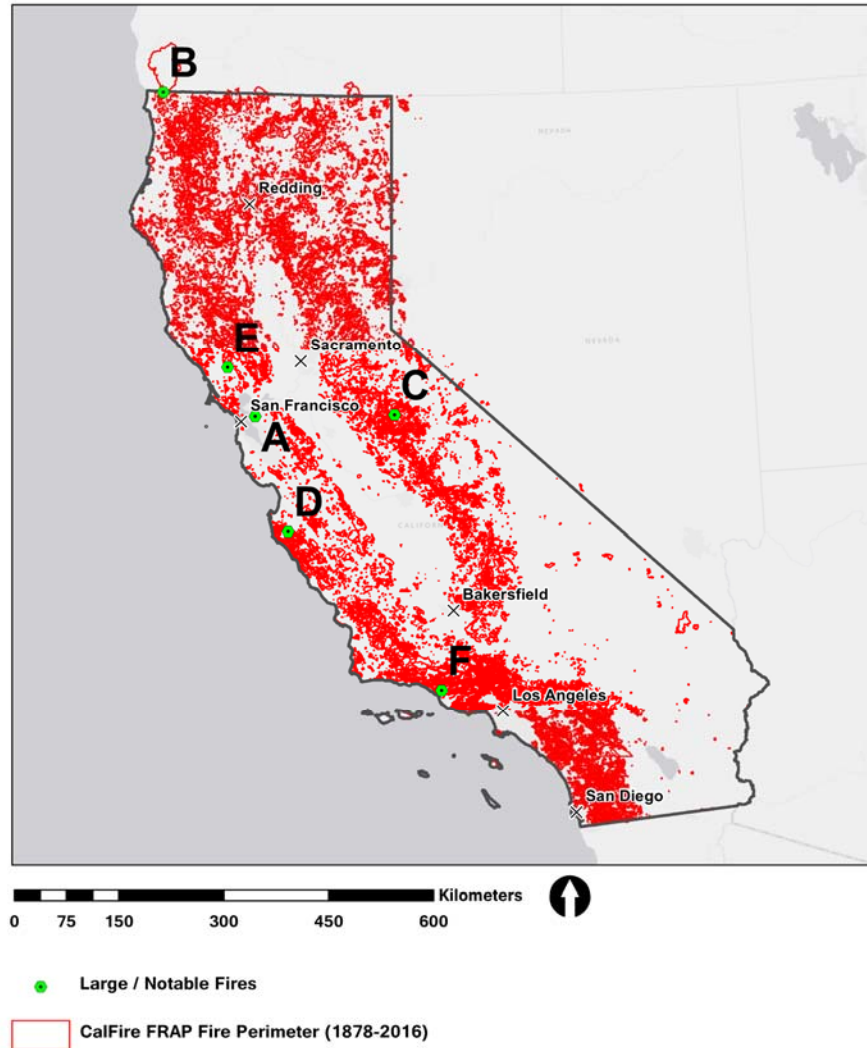

Figure D 2. Wildfire perimeters included in the CAL FIRE FRAP database with large or notable fires labeled A to E. (A) the 1991 Tunnel Fire; (B) the 2002 Biscuit Fire; (C) the 2013 Rim Fire; (D) the 2016 Soberanes Fire; (E) the 2017 Tubbs, Atlas, and Nuns Fires; and (F) the 2017 Thomas Fire. Data Source: CAL FIRE FRAP Fire Perimeters Database version 17_1 (Accessed on April 19, 2018 at http://frap.fire.ca.gov/data/frapgisdata-sw-fireperimeters_download)

D.2.3 Assessments of Current California Wildfire Hazard and Threat Levels

Wildfire threat assessments require a description of the hazard being evaluated as well as a probability measure that describes the likelihood of the specified hazard. There are many ways to characterize wildfire-related hazards and to estimate likelihood. In this subsection, a diverse suite of existing wildfire threat assessment products will be reviewed that relate to California.

One of the most widely recognized and relied upon near-term wildfire threat assessments is the National Fire-Danger Rating System (NFDRS). This system underlies the 'Today's Fire Danger' signs posted outside most fire stations in California. This scale of wildfire threat has nationwide coverage and conveys a message that is readily understandable - the likelihood of a wildfire occurring changes over time and when the likelihood of occurrence is high, extra care should be taken to prevent ignition of wildland fire fuels. Model parameter values that are required for calculating the NFDRS include dead and live fuel moistures as well as fuel model type classification assignments for areas included in the run. These values are used to calculate fire potential and output wildfire spread components, energy release components, and burning indexes for evaluated regions (Burgan et al., 1997). The forecasts can be near real time or up to five days out from the time at which the forecast is made.

A national-scale dataset that maps current Wildfire Hazard Potential (WHP), at 240 m x 240 m (787 ft x 787 ft) spatial resolution, has been generated and distributed by Fire Modeling Institute at the USDA Forest Service Missoula Fire Sciences Laboratory (Dillon, Menakis, & Fay, 2015). The WHP assessment can be used to identify areas where the threat of uncontrollable wildfire throughout the United States exists (**Figure D 3**). The WHP assessment is created by first estimating rates of spread using wildfire behavior models. These values are then used to identify areas where emergency-responders are likely to have difficulty constructing fire breaks at a pace that would allow them to stop the expansion of an active fire perimeter. Areas where wildfires had the greatest potential to experience control failures are given a ranking of Very High. Using this assessment, one can see that conditions throughout the Intermountain West, and California especially, present the greatest potential for uncontrollable wildfire when compared to most of the Nation (**Figure D 3**) other than South Florida, portions of North Carolina, coastal Louisiana, and the Pine Barrens of New Jersey.

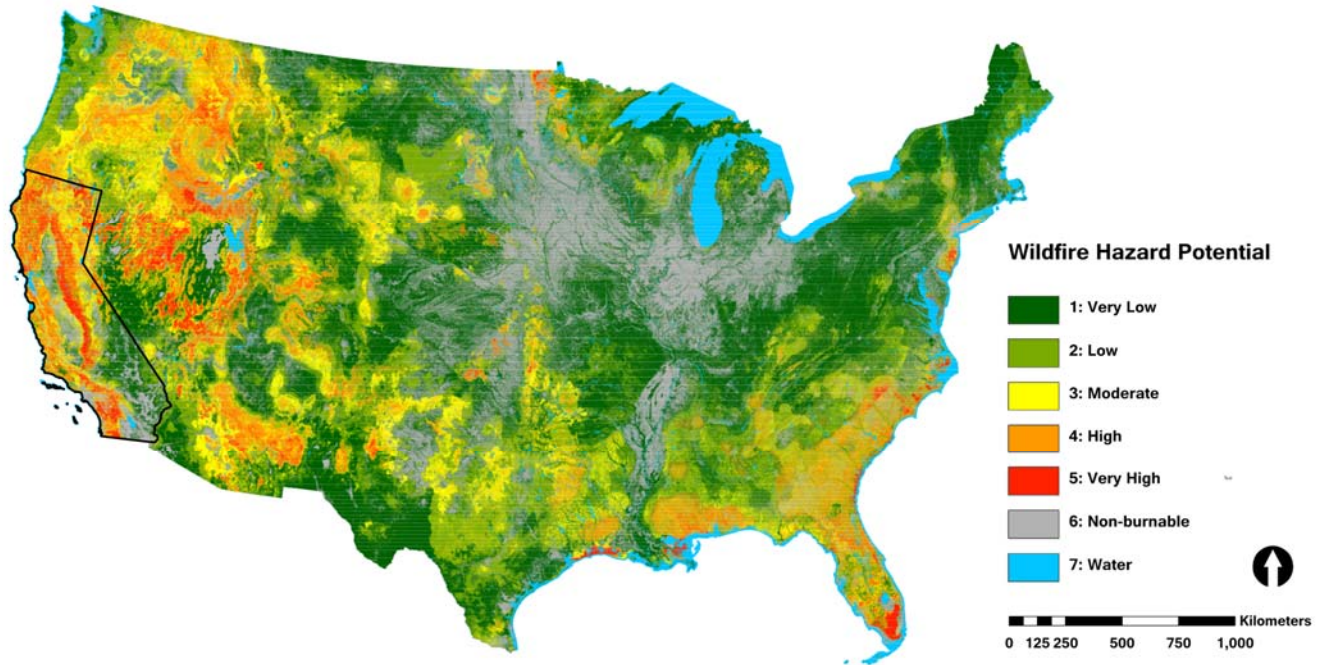

Figure D 3. Wildfire Hazard Potential (WHP) for the conterminous United States. Very high values represent areas where there is the greatest potential for wildfires to occur that are difficult to control. (Data Source: Dillon, 2015).

Wildfire threat assessments produced by CAL FIRE FRAP can be used to evaluate near-term wildfire hazard potential within the California region. FRAP has defined wildfire threat as being a combined index of expected wildfire frequency and potential wildfire behavior. The FRAP Wildfire Threat Index (WTI) was first produced in 2005 using the spatially explicit Historical Fire Rotation Class (HFRC) product described in Section D.2.2 as well as Potential Fire Behavior (PFB) rankings (

Figure D 5) to determine the threat level within a lattice of 100 m (328 ft) square grid cells covering the State. The PFB classifications are influenced by the types of fuel present at evaluated sites as well as the topographic factors (slope and aspect) known to affect wildfire behaviors. Vertical fuel profile characteristics, such as canopy base height, are also considered when assigning PFB rankings to areas of the State in order to account for variation that existed between site-specific potentials for surface fires to reach the canopy strata and initiate crown fire.

The 2005 FRAP WTI (**Figure D 4**) was first published in California's Forests and Rangelands: 2010 Assessment (California Department of Forestry and Fire Protection Fire and Resource Assessment Program, 2010). This assessment was produced to meet State level requirements for natural resource inventories while also satisfying some of the requirements of the 2008 Farm Bill, which required the Department of Agriculture to coordinate with California's forest and rangeland assessments.

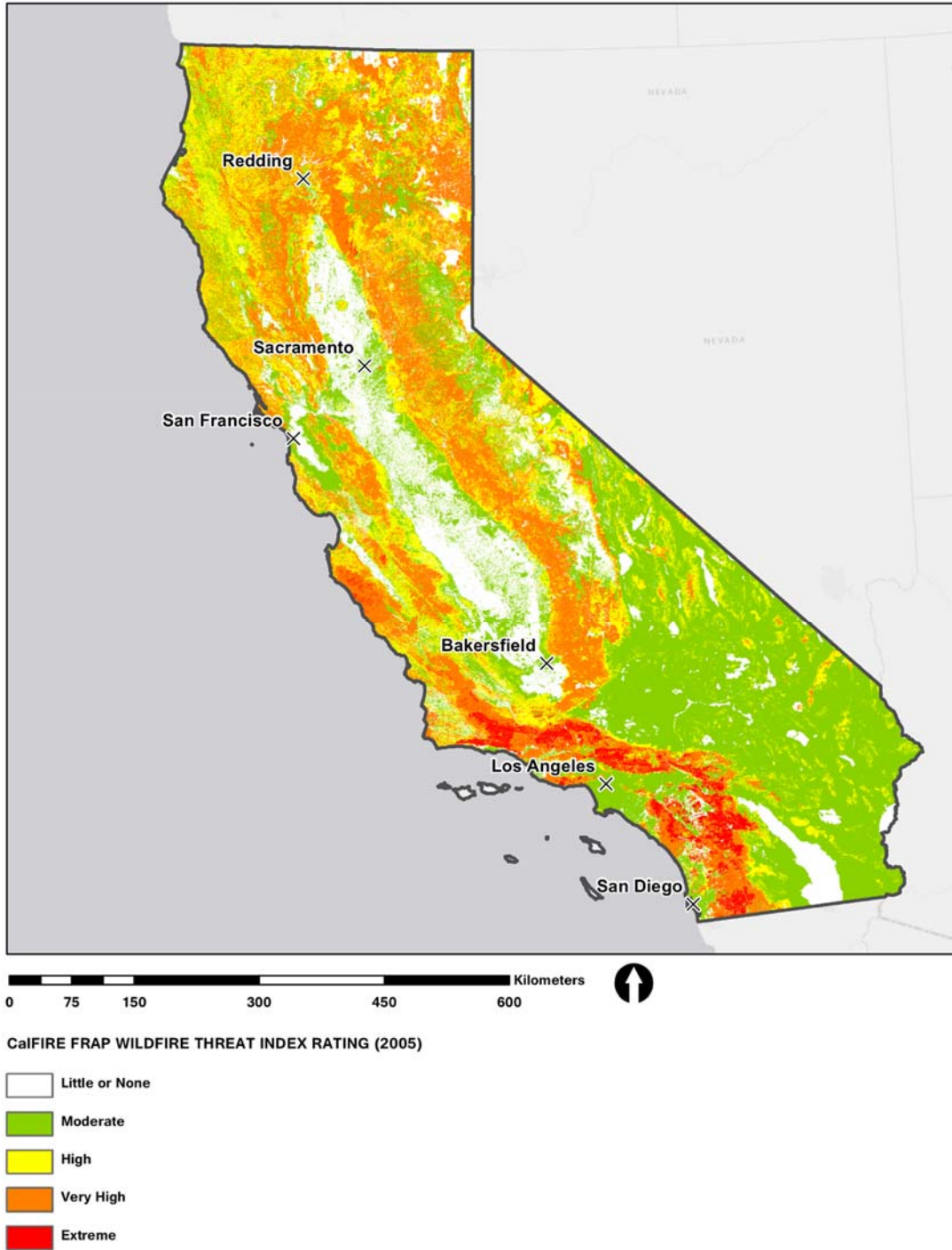

Figure D 4. The 2005 CAL FIRE FRAP Wildfire Threat Index (FRAP-WTI). Areas with Extreme (red), Very High (orange), High (yellow), and Moderate (green) FRAP-WTI scores are shown along with areas that faced little or no wildfire threat (grey).

According to the 2005 FRAP WTI, the threat of wildfire is most extreme in coastal regions of Southern California and in mountainous terrains surrounding L.A. and San Diego. Heavily

forested portions of the Sierra Nevada faced very high WTI conditions while little to no threat of wildfire is found in the irrigated agricultural zones of the Sacramento Valley or the San Joaquin Valley. A lack of wildfire threat is also observed in much of southeastern California, where sparsely vegetated desert land cover types contained small amounts of combustible material (fuels).

In 2017, FRAP released an updated wildfire threat index that incorporated updated PFB rankings – this time FRAP referred to the fuel hazard classification component of the index as Fuel Ranks. The revised PFB component of the wildfire threat index reflected changes in land cover that occurred between 2005 and 2014. A LANDFIRE digital raster data set is used to identify places where disturbance driven changes in land cover classifications had occurred in California (Jin et al., 2013). The LANDFIRE disturbance layer is used to provide location specific information on changes in vegetated land cover types that are the result of wildfire, development, insect activity, disease, windthrow, and other forms of disturbance that took place between 2003 and 2012. The disturbance information taken from the LANDFIRE dataset is then used in conjunction with known revegetation patterns and resulting changes in land cover classifications that had been observed between initial times of disturbances and 2014 to produce final 2017 Fuel Rankings shown in **Figure D 5** (T. Moody, Personal Communication, 2017).

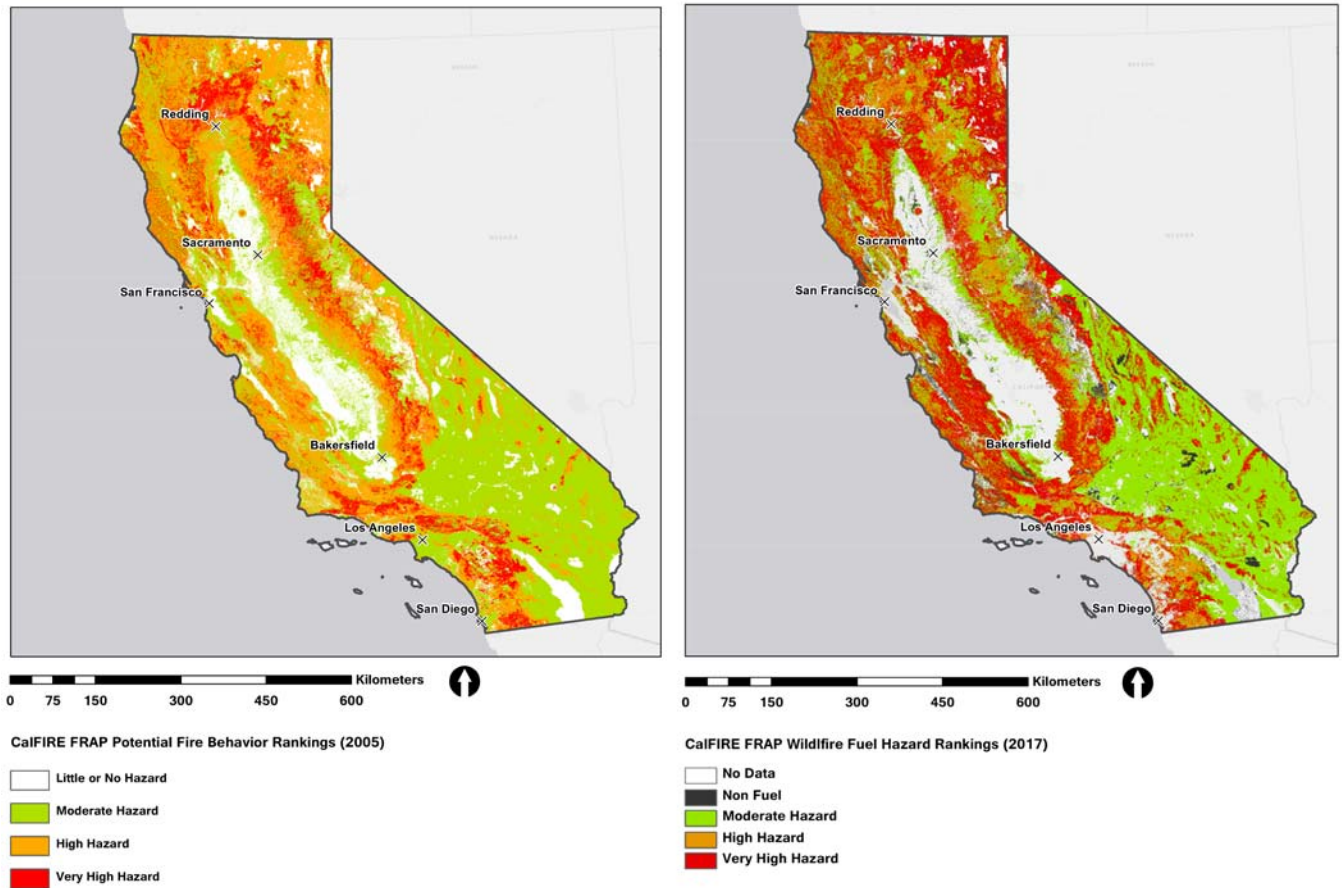

Figure D 5. Potential Fire Behavior (PFB) rankings produced by FRAP in 2005 (left) and 2017 (right).

Unfortunately, making direct comparisons between the 2005 and the 2017 fuel hazard rankings for the purposes of detecting change over time proved to be problematic given that significant differences existed between the two datasets. The 2005 PFB ranks, for example, used a fuel hazard classification method that assigned ratings of Little or No Hazard, Moderate, High, and Very High while the 2017 dataset had Fuel Rank classes labeled Non-Fuel, Moderate, High, and Very High. The datasets are also distributed at two different spatial resolutions: the 2005 data was at 100 m (384 ft), while the 2017 dataset was at 30 m (98.4 ft). We make an effort to overcome these differences and detect where changes in wildland fire fuel hazards are likely to have occurred during the decade that separated the release of these similar FRAP data products. The 100 m 2005 FRAP PFB dataset is resampled to a 30 m (98.4 ft) raster using the nearest neighbor resampling technique. An attempt is then made to determine where, and to what degree, other changes in fuel hazard rankings had occurred. Areas labeled as Little or No Hazard (2005) or as Non-Fuel (2017) are excluded from this portion of the analysis. The preliminary results of this investigation are depicted in **Figure D 6**.

Figure D 6 shows wildfire, timber harvesting, and other disturbance events that occurred in the northern regions of the Sierra Nevada and areas north of Redding may have decreased fuel loads and lowered the FRAP fuel hazard rankings. Most areas of the State, however, saw localized wildfire-fuel related hazard levels dramatically increase between 2005 and 2017.

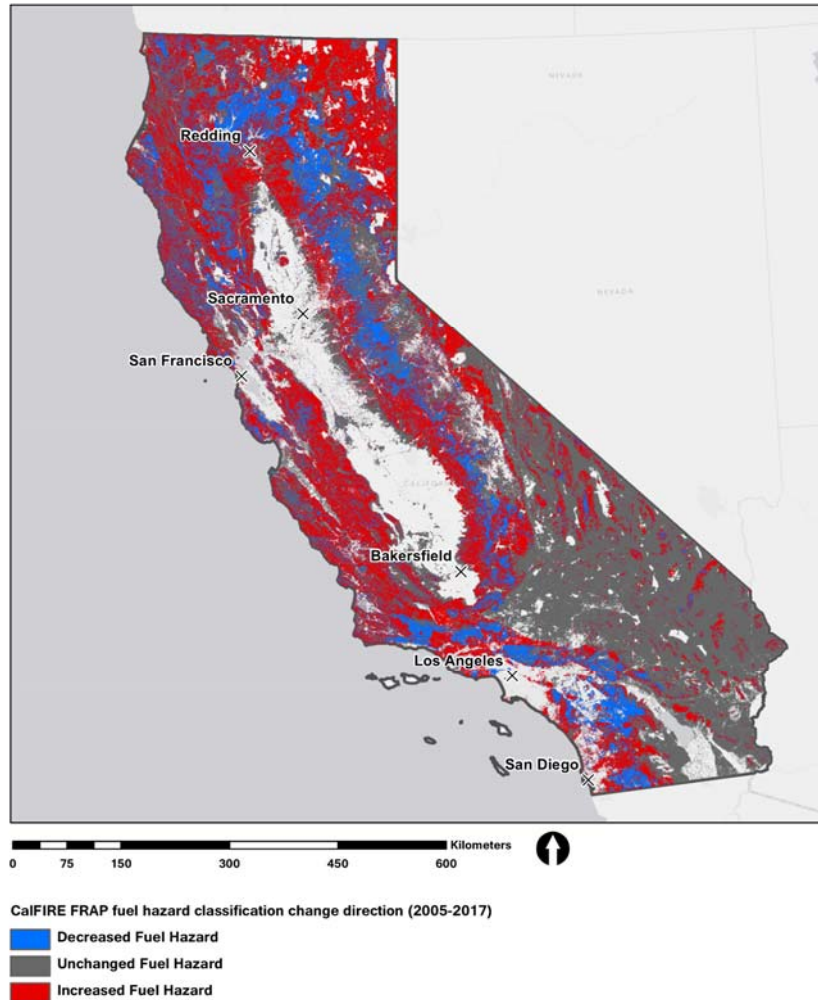

Figure D 6. Direction of change (increase, decrease, or no change) in CAL FIRE FRAP Fuel Threat Rankings between the 2005 and 2017 releases (left). Note that areas that were unassessed in the 2017 data release were excluded from this analysis.

D.2.4 Wildfire Hazard and Threat Projections for California

Westerling's (forthcoming) research produced near, intermediate, and long-term wildfire forecasts for California. The specific wildfire threats addressed in Westerling's modeling efforts included the likelihood of large wildfire as well as the likelihood of high severity wildfire at discrete time steps and locations. This section describes Westerling's modeling framework and data inputs used to generate wildfire projections for California's Fourth Assessment on Climate Change. It concludes with a summary of the modeled wildland fire futures at regional and sub-regional levels of analysis.

D.2.4.1 Overview of Wildfire Projection Scenarios

Wildfire projecting models are run by Westerling (forthcoming) under specific scenarios designed to reflect the effects of climate change and population growth over time (**Figure D 7**). Each wildfire projection scenario is developed from outputs of a single general circulation

model, or global climate model (GCM), run under a specific greenhouse gases emissions scenario. Outputs from each of the GCM considered are bias corrected and downscaled to a spatial resolution of 1/16th degree x 1/16th degree using localized constructed analog (LOCA) models. Climate variables from each of the GCM runs are then passed into a variable infiltration capacity (VIC) hydrodynamic model to produce estimates of other weather variables that impact the probability and characteristics of a wildfire occurrence. For more information on LOCA and VIC models see Appendix B. GCMs used to generate climate variables included, the CanESM2 earth system model generated by Canadian Centre for Climate Modelling and Analysis; the CNRM-CM5 earth system model generated by the Centre National de Recherches Météorologiques, the HadGEM2 coupled earth system model generated in the UK by the Met Office Hadley Centre, and the MIROC5 earth system model International Centre for Earth Simulation in Tokyo. GCMs are each run under two different Representative Concentration Pathways (RCPs); a comparatively high emissions scenario (RCP 8.5) and a comparatively moderate to low emissions scenario (RCP 4.5). The numerical portions of RCP names referred to the amount of radiative forcing, measured in $W/(m^2)$, expected to be observed by 2100. Expected impacts of projected population growth on spatiotemporal patterns of development in California are also integrated into Westerling’s wildfire future modeling routine. Spatially explicit estimates of land cover and land use conditions are modeled by (Sleeter, Wilson, Sharygin, & Sherba, 2017) to support Fourth Assessment research projects using low, central, and high population growth estimates produced by the California Department of Finance. In order to account for the uncertainty surrounding the spatial patterns of future population growth and development, ten Monte-Carlo simulations are run to produce land cover classifications (Sleeter et al., 2017). These spatially explicit predictions of land cover changes over time are used to determine the percentage of vegetation per wildfire forecasting cell at each time step. For more information on the inputs to each wildfire future scenario modeled by Westerling (forthcoming), refer to Appendix B.

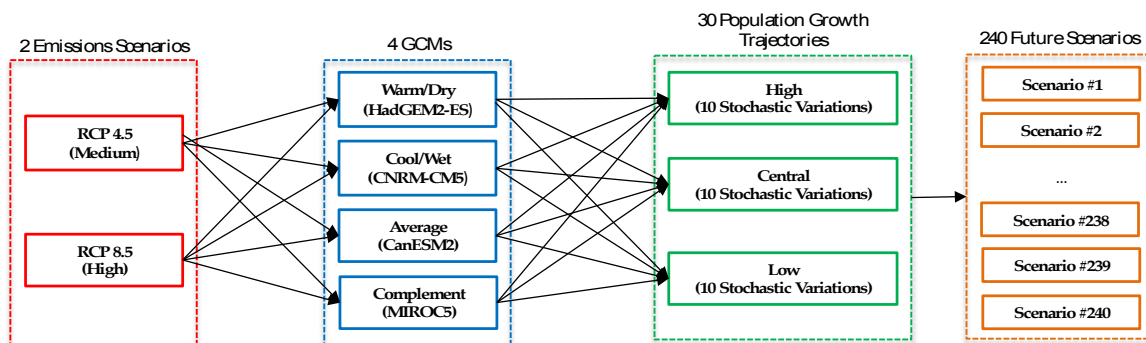

Figure D 7. Overview of wildfire projection scenarios modeled by Westerling (forthcoming).

D.2.4.2 Overview of Modeling Framework used to Generate Wildfire Projections

Westerling modeled a total of 240 wildfire projection scenarios to estimate the likelihood of large wildfire occurrence at each timestep and location considered. Likelihood estimates are then used to derive additional estimates of wildfire occurrence, size, and severity over time and space. To arrive at each of these additional estimates, Westerling relied upon a probabilistic-statistical linked modeling framework that included four separate mathematical models and empirical data collected from wildfire history records. In the first step of Westerling’s

framework, a linear predictor of burn state is estimated for each 1/16th degree grid cell within the study area extent using logistic regression. The linear predictors are then used to calculate the probability of the presence and the absence of wildfire within each grid cell at monthly time intervals and to determine the parameters of a Generalized Pareto Distribution for thirty spatially explicit population growth influenced estimates of wildland fuel (vegetation) availability. Outputs of step one also included logit estimator derived from linear predictor parameters. A second model is then initiated using the probabilities of fire presence and absence generated in the first step to create binary distributions and simulate the presence or absence of burning for each month. A third model is then activated to compute the number of wildfires that occurred if presence is established during the running of the second model. Wildfire occurrence counts could take on a value of zero, one, or two. Poisson lognormal distributions constructed from the linear predictors generated by the first model and the burn distributions generated by the running of the second model are used to determine the wildfire occurrence count. In the last stage of Westerling's multi-step approach a fourth model is used to simulate wildfires that are larger than 400 hectares (approx. 988 acres or 1.5 square miles) in size using the Generalized Pareto Distribution parameters created during the first step and the monthly fire numbers generated when the third model is run. Fire sizes are not allowed to exceed the size of the largest fire observed in the State during the period in which historical fire records were collected and published in the Monitoring Trends in Burn Severity database (See Section D.2.2). Outputs from the fourth model included estimates of area burned by wildfire during a single monthly time step in each 16th degree cell modeled. The fourth step in Westerling's linked modeling routine is then run ninety-nine more times to produce a total of one-hundred monthly estimates of area burned within each prediction cell. Westerling then averaged all 100 values for each grid cell to produce a single estimate of area burned by wildfire for each month. Lastly, monthly mean estimates of area burned by wildfire are annualized for years between 1953 and 2100 to produce 147 estimates of area burned by wildfire for each of the 240 wildfire projection scenarios modeled. We use the full set as well as select subsets of annualized mean estimated values to characterize regional and sub-regional trends in expected wildfire frequency and size (total area burned per year) during data processing and analysis phases of our work with Westerling's futures data.

D.2.4.3 Overview of Wildfire Projection Data Processing and Analysis

After Westerling and other Fourth Assessment Researchers determined that there is little difference between estimates generated from the ten stochastic variations of land cover developed for each population growth trajectory modeled, the number of datasets included in further steps of our analysis is reduced by ninety percent, from 240 to 24, by averaging all values from like population growth scenarios for each time-step and prediction cell together to produce one dataset for each GCM+RCP+PopGrowth scenario modeled (B. Sleeter, Personal Communication, 2017; D. Storms, Personal Communication, 2017; CalAdapt, 2017). We refer to the average annualized mean estimated values (MEV) for area burned by wildfire within each of Westerling's prediction cells as MEVs throughout our analysis of these projection data.

To analyze Westerling's outputs we first determined median MEVs as well as specific median MEV percentile break values at annual, decadal, and double decadal time scales. Trends in these MEV summary values are analyzed in Section D.2.4.4. We then use the double-decadal median MEVs to construct a Modeled Wildfire Threat Rating (MWTR) system described in Section D.2.6. Annual median MEVs also serve as inputs to a space-time hotspot analysis that aims to shed light on spatio-temporal trends in areas burned by wildfire. A detailed description

of the methods and parameters used in the space-time hotspot analysis is included in Section D.2.4.4.

D.2.4.4 Summary and Analysis of 4th Assessment Wildfire Projection Scenarios Modeling Results

Westerling's (forthcoming) Fourth Assessment projections of wildfire futures cover a wide range of estimated values due to the large number of scenarios modeled. **Figure D 8a-8d** provides line plots of decadal median MEVs for each of the wildfire projection scenarios modeled.

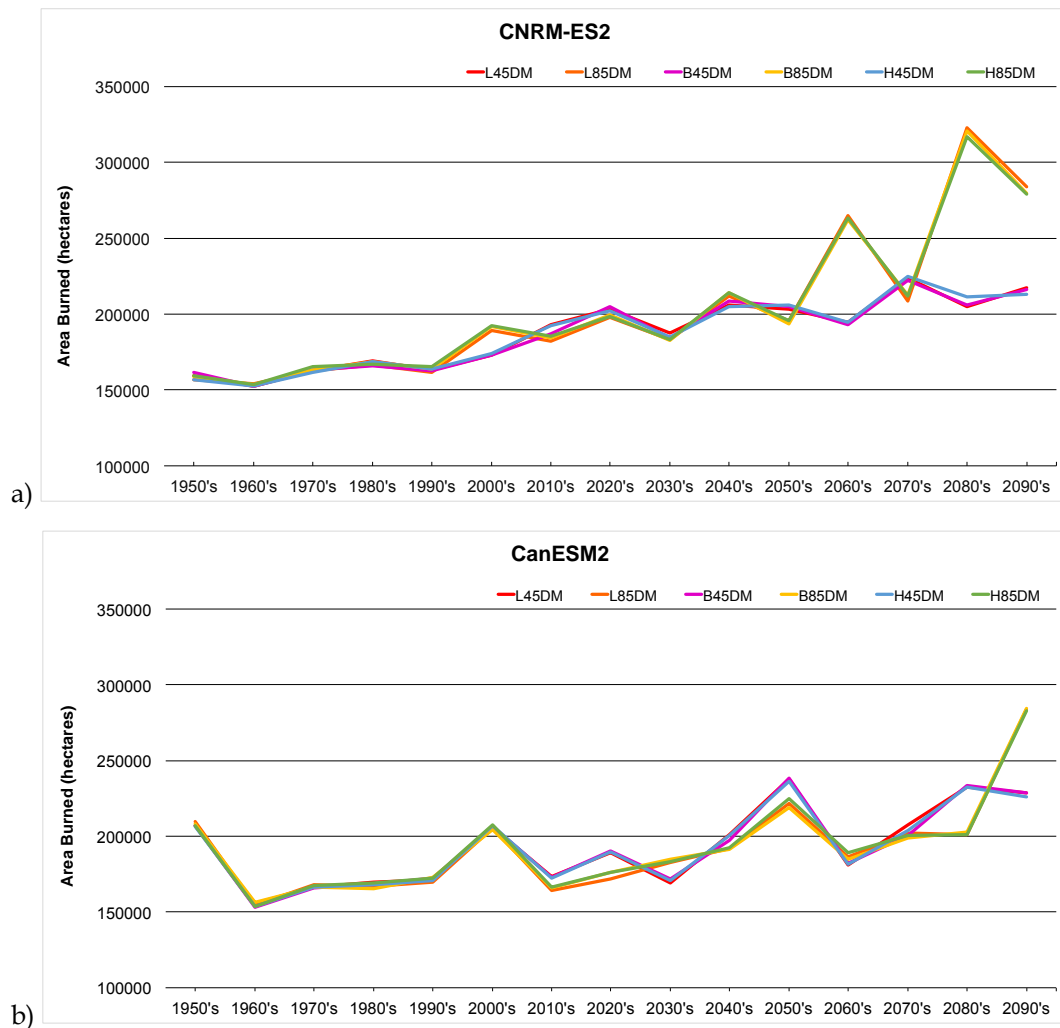

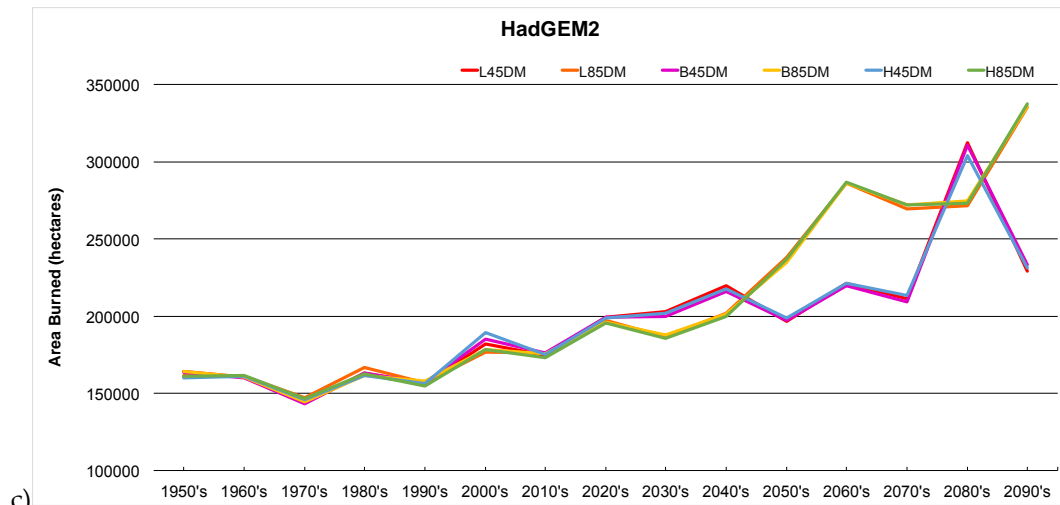

c)

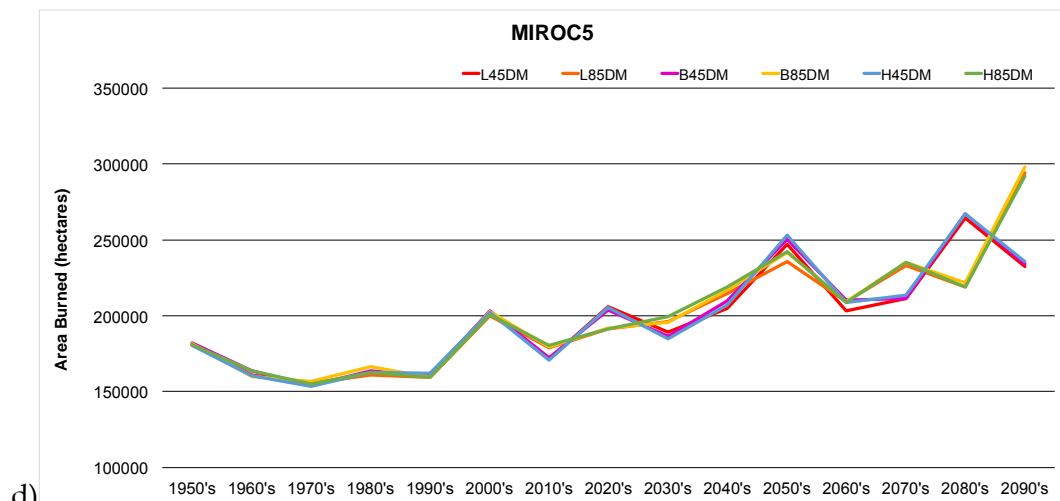

d)

Figure D 8. Decadal median estimates of area burned by wildfire in California for entire modeled period. All wildfire projection scenarios modeled by Westerling (forthcoming) shown. Separate lines within each of the four charts represent trends in decadal median MEVs of area burned by wildfire between 1953 and the year 2100 one of the three different population growth scenarios (Low, High, and Business-as-Usual) incorporated into the wildfire futures modeling routine.

Figure D 8a-d and **Figure D 9** depict the statewide median MEVs of area burned by wildfire annually during each of the decades modeled. Each line represents the results of a unique GCM+RCP+LULCcond scenario modeled. The cubic structure of square blocks is included in **Figure D 8a-d**,

Figure D 9, and **Figure D 10** to provide an overview of the set of permutations modeled by Westerling's research (forthcoming). The difference between maximum and minimum MEVs of area burned by wildfire increases with time. These values diverged at a greater rate after 2040 for many of the scenarios modeled; which is to be expected given the underlying definitions for each of the RCPs modeled (See Appendix B).

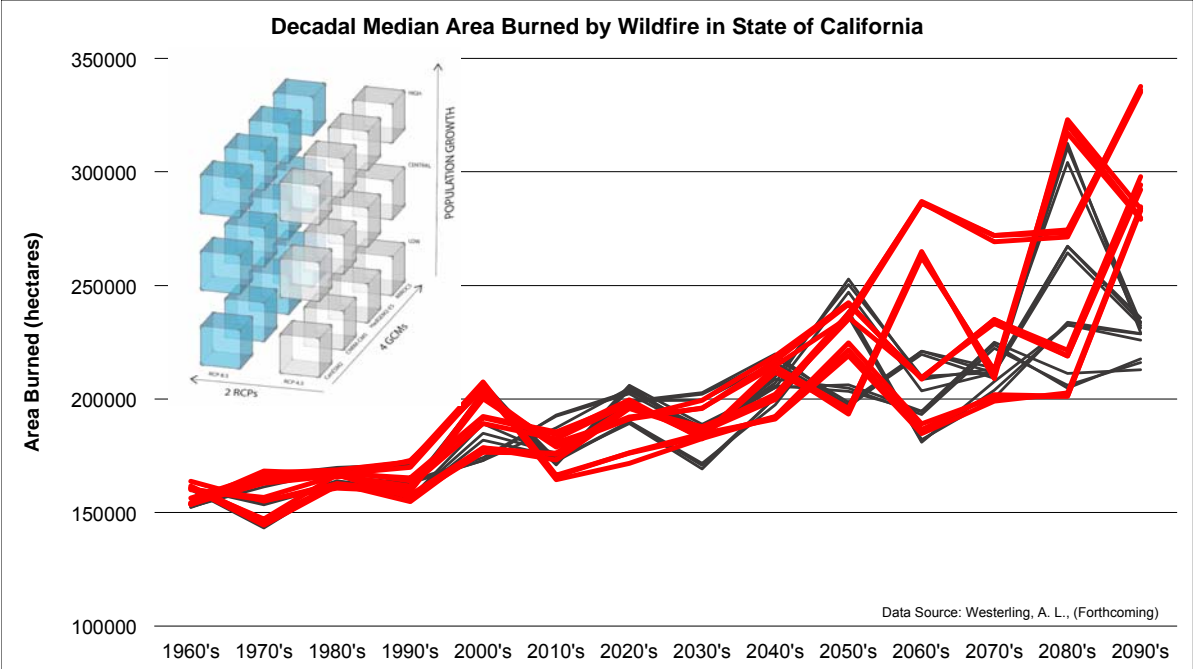
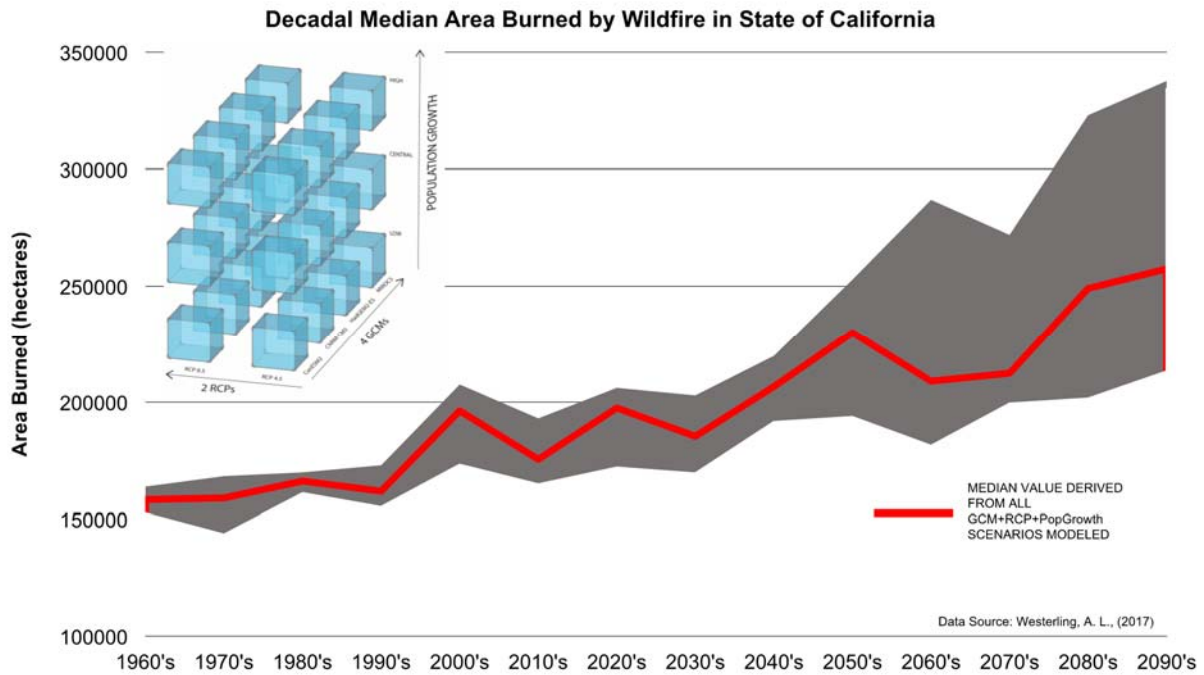

Figure D 9. Decadal median MEVs of area burned by wildfire in California from 1960 until 2100. All wildfire projection scenarios modeled by Westerling (forthcoming) shown. Red line represent trends in decadal median MEVs for RCP 8.5 model runs and the dark grey lines represent trends in decadal median MEVs for RCP 4.5 model runs.

a)



b)

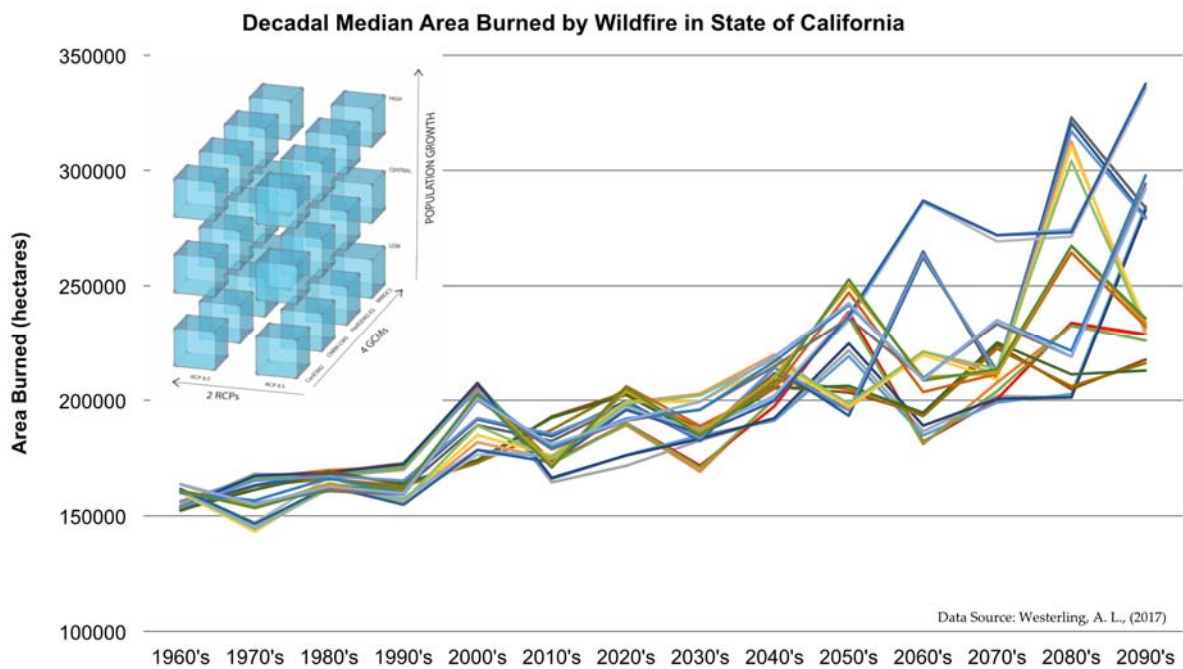

Figure D 10. Decadal median MEV trends for area burned by wildfire in California. (a) All wildfire projection scenarios modeled by Westerling (forthcoming) shown as separate colored lines. Minimum and maximum MEV for each decadal period was found from a pool of values containing outputs from all wildfire projection scenarios modeled (b). Maximum and minimum MEVs are then used to create the dark great grey envelope surrounding a single red line. This single red line passing through the grey envelope represents the median MEV for each decadal period selected from a set of values containing outputs from all wildfire projection scenarios modeled.

Wildfire patterns are expected to vary throughout California over the remainder of the current century. Increases, decreases, and relatively insignificant changes in wildfire frequency and/or magnitude are projected to occur within sub regions of the State (**Figure D 11** and **Figure D 12**). Modifications to current wildfire patterns are expected to be largely driven by changes in land cover and wildland fuel stocking levels, as well as by fluctuations in local climate conditions over time. Coastal areas are expected to see small changes in wildfire risk between now and the end of the century. The TFS assets in forested portions of the State are expected to experience a marked increase in exposure to wildfire over this same period of time.

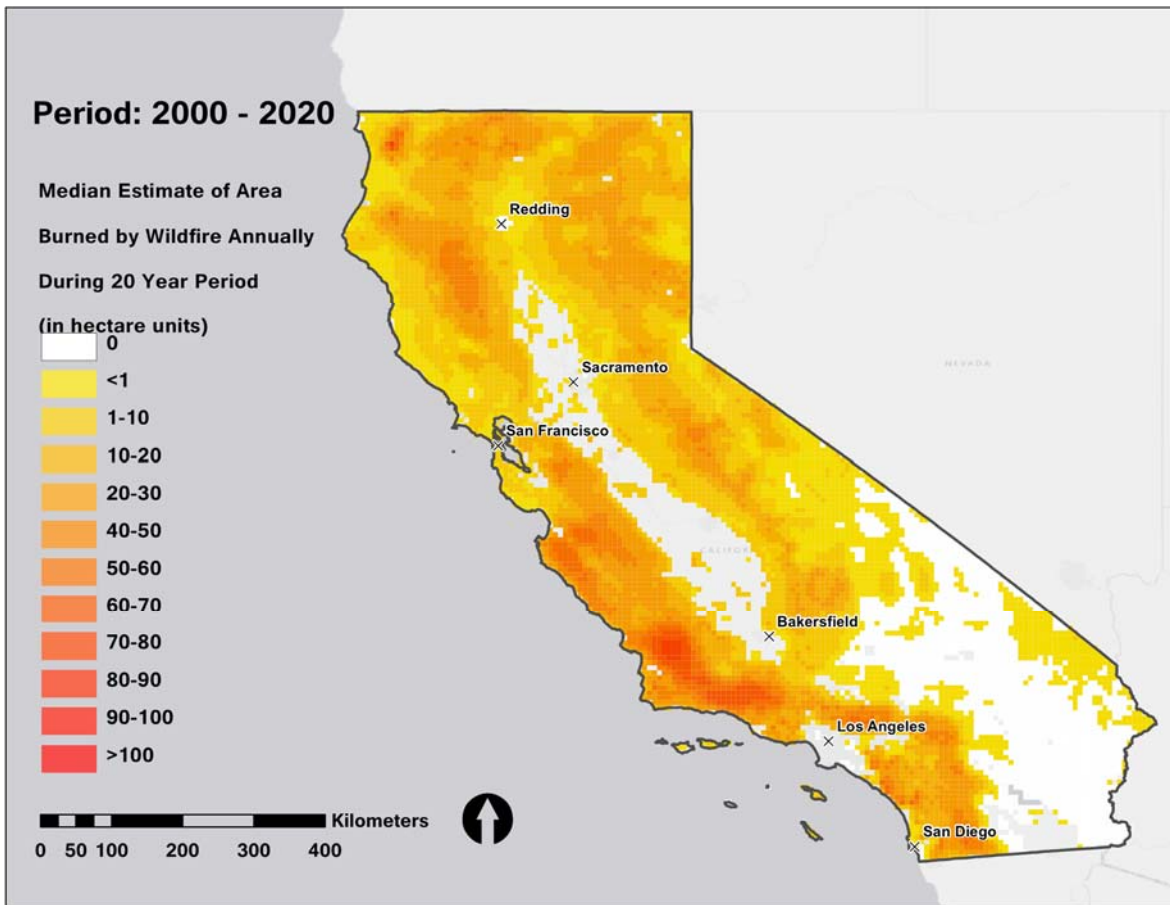

Figure D 11. Median modeled estimates of area burned by wildfire annually within 16th Degree Latitude x 16th Degree Longitude climate forecasting cells for the current twenty-year period (2000 - 2020).

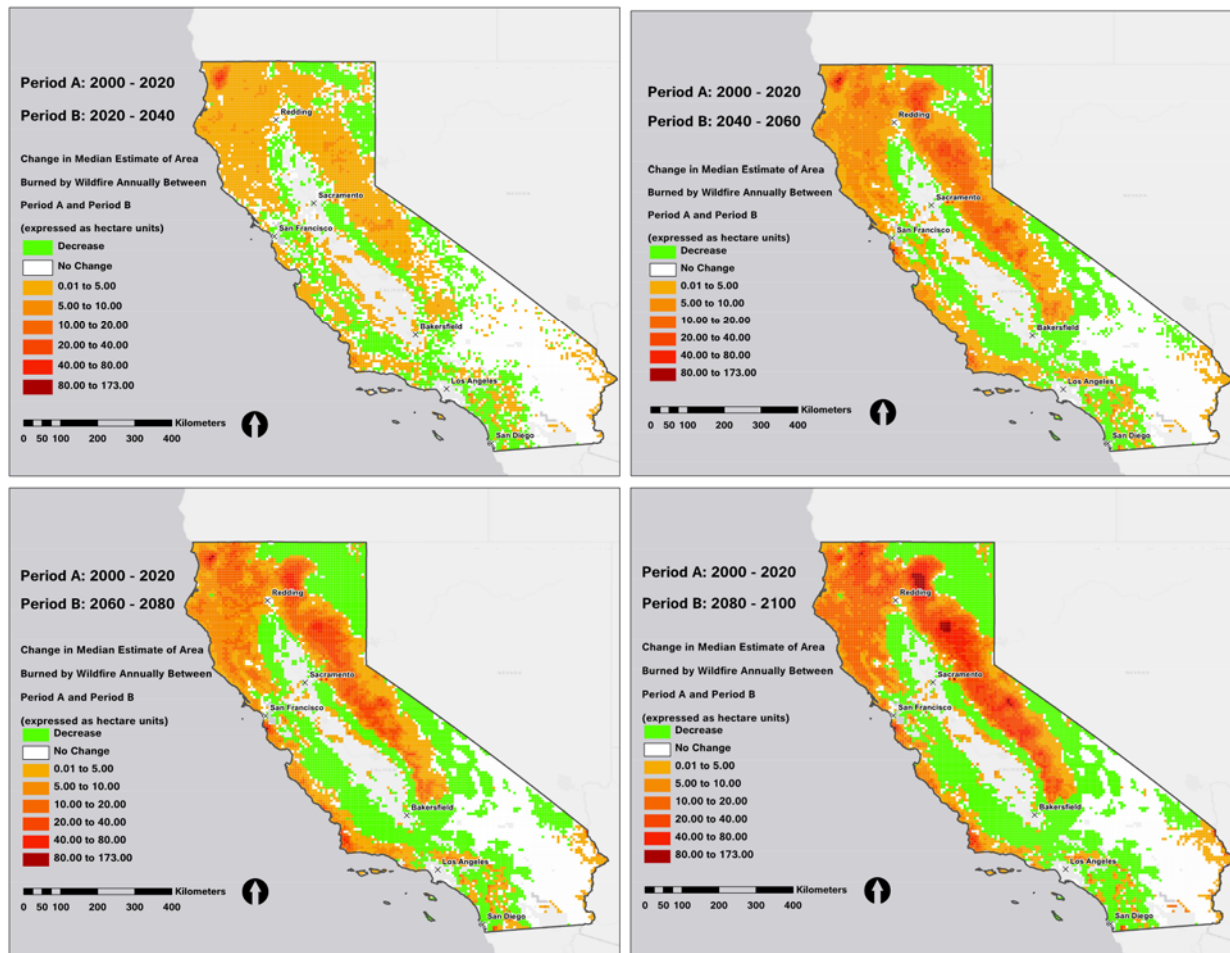

Figure D 12. Inter-Period Changes in median modeled estimates of area burned by wildfire annually within 16th Degree Latitude x 16th Degree Longitude climate forecasting cells for the current twenty-year period. (Top Left: 2000 - 2020 vs 2020-2040) (Top Right: 2000 - 2020 vs 2040-2060) (Bottom Left: 2000 - 2020 vs 2060-2080) (Bottom Right: 2000 - 2020 vs 2080-2100)

D.2.5 Exploring Spatial and Temporal Patterns of Large Wildfire Threat-identifying Localized Hot Spots

Analyzing and understanding wildfire spatial-temporal patterns and trends enhances our ability to allocate resource and prioritize hazard and risk mitigation efforts in areas most vulnerable to large catastrophic fires. Mapping statewide projections of fire occurrence and identifying hot spot areas helps identify locations that will be increasingly threatened by wildfires in the near, and distant future. We classify a location as a “hot spot” if it has a high value of number of hectares burned and is also surrounded by areas that also have high values. There are a number of different types of hot spots (see **Table D 1**). Visually representing hot spot areas provides insight on the spatial distribution of wildfire threat. Furthermore, mapping hot spot patterns statewide not only enhances our understanding of California’s dynamic wildfire regimes, but also helps identify areas where fire risk is projected to increase, decrease, or remain the same.

The Space Time Cube function in ESRI's Arc Pro software (ESRI 2017). ArcGIS Pro version 1.4. Redlands, CA: Environmental Systems Research Institute) is used to aggregate Westerling's median MEVs into space-time bins. Within each bin, the median values for the number of hectares burned in each cell are grouped. We examined the median values of the MEVs because we considered this to be a conservative representation of the model projections across the different models analyzed. By excluding extreme values (minimum and maximum values) and solely looking at the median model prediction values, we can showcase moderate estimation of statewide wildfire threat until the end of the century.

We aggregate the data on a yearly basis for each time period studied (2000-2020, 2000-2040, 2000-2060, 2000-2080, and 2000-2100). We pick the year 2000 as a reference point since it marks the beginning of the 21st century. When running the Space Time Cube function, we set the time step parameter as 1 year since we want to capture a yearly progression of modeled wildfire threat. The number of aggregated space time cubes, or bins, varies based on the length of time studied. For example, the first time period, 2000-2020 has 20 bins since it is up to 2020 but not including 2020, the second, 2000-2040 has 40 bins since it does not include 2040, and so forth in 20 year increments until we reach the end of the century. Each bin encompasses a single year containing the median values for the number of hectares burned.

Since the original size of our data is 1/16 of a degree which translates to approximately 6.91 km or 6,910 m, the distance interval (parameter which specifies how large each bin is) is set as 6,910 m. This number is slightly more than the cell size of 6.2 km by 6.2 km used in the previous maps due to a minor difference in the format of the data. Specifically, Westerling's original statewide grid cell data is made up of rectangles (not squares), since he uses the 1/16 of a degree as a measurement of distance. In contrast, the space time cube requires the area analyzed to be divided into a grid cell made up of squares. Therefore, the center of each rectangle does not perfectly coincide with the center of the squares if the size of a side of a square grid cell would be set as 6.2 km. Using a larger cell size of 6.91 km ensures that all the centers of Westerling's grid cells are accurately represented in the statewide square grid cell pattern created by the space time cube function. Consequently, when creating the space time cubes, we keep the spatial parameter consistent to our original input data as much as possible.

Furthermore, when applying the space time cube function, within each bin of the cube, the points are counted, and the Summary Field statistic (in this case the median value for each bin) is calculated. The trend for bin values across time at each location is measured using the Mann-Kendall statistic. When dealing with missing values (if any), these values are filled with the average value of the spatial neighbors surrounding the empty bin.

The Emerging Hot Spot spatial analysis function is used to investigate trends over space and time, and to determine whether these trends are increasing, decreasing or remain consistent. The function classifies bins as hot or cold spots using the Getis-Ord G_i^* statistic. Each data point is analyzed within the context of its neighbors. Therefore, a hot spot is identified when a feature (space-time bin) has a high value and is also surrounded by other features with high values. The parameter values for Neighborhood Distance and Neighborhood Time Step define the extent of each bin's neighborhood. The Neighborhood Time step is set to 2, and the Neighborhood Distance is set to 13,821 (which is calculated as $6,910 * 2 + 1$) m. Given these parameters, the spatial neighbors extend two bins both horizontally and vertically, and one bin out diagonally. Based on the trends recorded, the final output of the function classified the landscape into 17 distinct categories representing varying degrees of hot spots, cold spots, and areas where no

trend is detected. However, we are solely interested in viewing areas classified as varying degrees of hot spots (new hot spot, consecutive hot spot, intensifying hot spot, persistent hot spot, diminishing hot spot, sporadic hot spot, oscillating hot spot, and historical hot spot) (Table D 1).

Table D 1. ESRI Emerging Hot Spot Categories Descriptions

New	A location that is a statistically significant hot spot for the final time step and has never been a statistically significant hot spot before.
Consecutive	A location with a single uninterrupted run of statistically significant hot spot bins in the final time-step intervals. The location has never been a statistically significant hot spot prior to the final hot spot run and less than ninety percent of all bins are statistically significant hot spots.
Intensifying	A location that has been a statistically significant hot spot for ninety percent of the time-step intervals, including the final time step. In addition, the intensity of clustering of high counts in each time step is increasing overall and that increase is statistically significant.
Persistent	A location that has been a statistically significant hot spot for ninety percent of the time-step intervals with no discernible trend indicating an increase or decrease in the intensity of clustering over time.
Diminishing	A location that has been a statistically significant hot spot for ninety percent of the time-step intervals, including the final time step. In addition, the intensity of clustering in each time step is decreasing overall and that decrease is statistically significant.
Sporadic	A location that is an on-again then off-again hot spot. Less than ninety percent of the time-step intervals have been statistically significant hot spots and none of the time-step intervals have been statistically significant cold spots.
Oscillating	A statistically significant hot spot for the final time-step interval that has a history of also being a statistically significant cold spot during a prior time step. Less than ninety percent of the time-step intervals have been statistically significant hot spots.
Historical	The most recent time period is not hot, but at least ninety percent of the time-step intervals have been statistically significant hot spots.

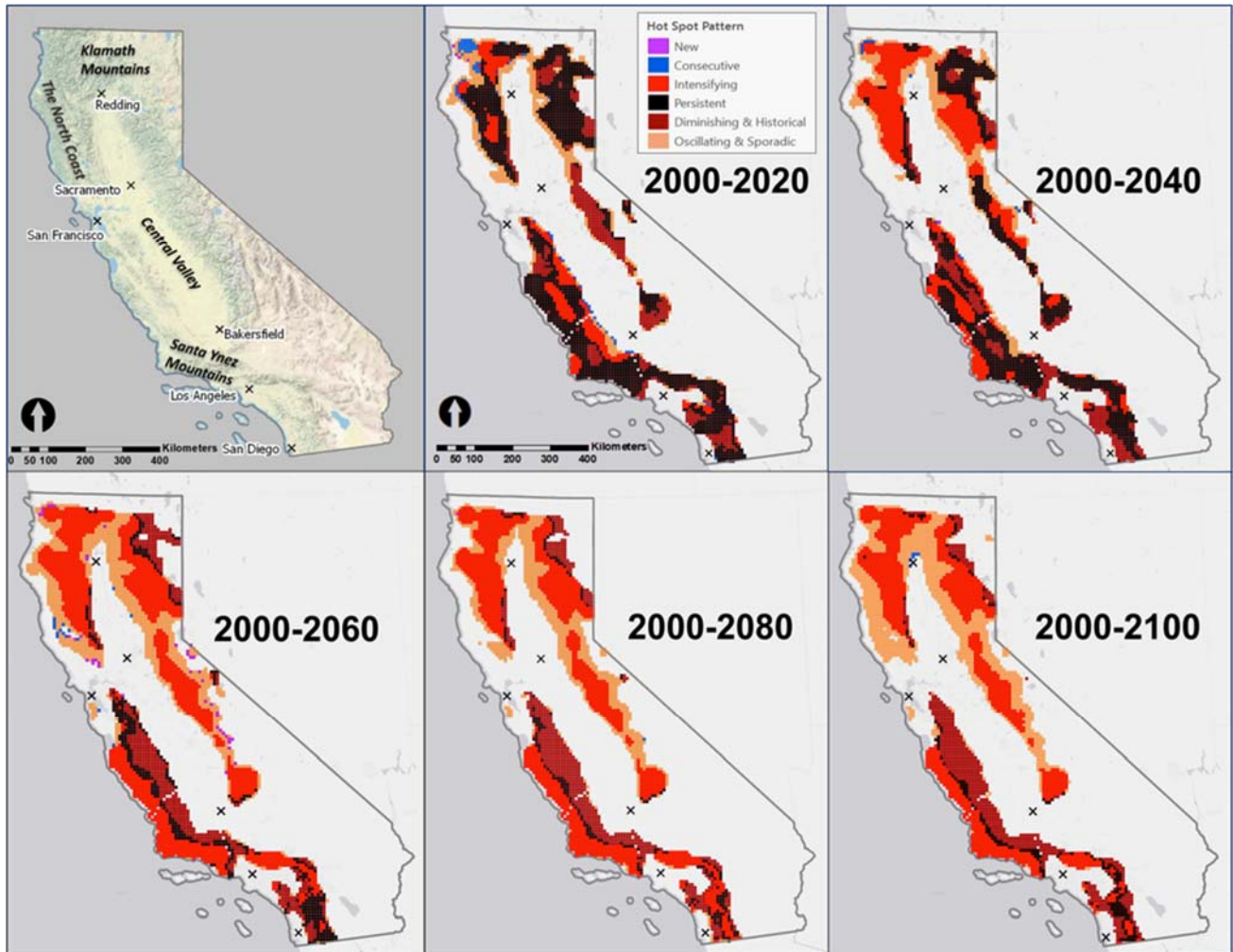

Figure D 13. Outputs of ESRI's Emerging Hotspot Tool. Only Hotspot classifications shown.

When analyzing the Figure D 13, it is important to understand that it illustrates a gradual progression through time of projected wildfire threat from 2000 until the end of the century. Specifically, even if in the map depicting the period 2000-2080 some areas are characterized by diminishing hot spots, they are initially classified as intensifying hot spots in a previous time period such as 2000-2020. An example of this is illustrated by looking at areas north-east of Los Padres National Forest, north of Santa Barbara. Consequently, when looking at a point in time, it is important to consider all the previous time steps and grasp the dynamic characteristic of modelled fire threat across the state.

From the results of the Emerging Hot Spot Analysis of the Space Time Cube (2000-2100) specific trends can be observed:

- In the periods following 2020, more and more intensifying hot spots are detected throughout the state.
- There are relatively few new (purple areas) and consecutive (blue areas) hot spots detected.

- The north-eastern part of the Central Valley foothills is predominantly characterized as an oscillating and sporadic hot spot (orange) across all time periods analyzed.
- The time periods 2000-2020 and 2000-2040 are characterized by a large number of areas experiencing persistent hot spots (black). These areas, then become classified as intensifying hot spots in the following periods studied.
- Areas located in close proximity to the coastline, along the North Coast (where precipitation values are among the highest in the State), do not exhibit a particular hot spot trend. However, moving eastward towards the Klamath Mountains, we notice an oscillating hot spot that turns into an intensifying hotspot over the mountain range.
- Areas along the South Coast, around the Santa Barbara (Santa Ynez Mountains) and areas of Los Padres National Forest are classified as an intensifying (red), then become a persistent hot spot (black) as we move eastward towards the Central Valley they become converted to a diminishing and historical hot spot (brown areas).

D.2.6 Modeled Wildfire Threat Rating System

The Modeled Wildfire Threat Rating (MWTR) system allows for the tracking of changes in wildfire threat over time. The MWTR system lets users determine how local large wildfire related threat levels are expected to vary throughout the 21st Century relative to the rest of the State and the reference time period (2000-2020). The MWTR system is created in the following manner. First, values from all 24 averaged MEV time-series data sets for area burned by wildfire annually within 16th degree x 16th degree estimation cells are used to find a median estimated MEV for each projection pixel for each year modeled. These median MEV values are then binned into five non-overlapping double decadal periods; 2000-2020, 2020-2040, 2040-2060, and 2060-2080. Median MEV estimates within each bin are then sorted to find the period-specific median estimates of area burned by large wildfire within each prediction cell. These median MEV estimates are then collected from all prediction cells for the 2000-2020 reference period and sorted into 26th, 50th, 75th, 90th, and 99th percentile bins. These percentile break values were then used to construct the MWTR class definitions. The lower boundary of the “Low” MWTR classification is set to the twenty-six percentile MEV value of 2 ha. Cells with median estimates falling below this value are labeled as being areas where “Little to No” threat of wildfire existed. The remaining percentile break values derived from reference period modeled estimates of area burned by large wildfire are used to define the MWTR classifications of “Low”, “Moderate”, “High”, “Very High”, and “Extreme” (**Table D 2**). The MWTR definitions are then applied the four remaining twenty-year periods.

Table D 2. Modeled Wildfire Hazard Rating (MWTR) level definitions and corresponding ranges of reference period median MEV of area burned by wildfire. Percentile break values were determined by examining a pool of estimates that included modeling outputs from All GCM and RCP permutations recommended for use by agencies managing the development of California's 4th Assessment on Climate Change.

MWTR Class	Class Definition for the Period 2000-2020 Median MEV falls within the specified percentiles of the distribution for all GCM and RCP models combined
<i>Little to None or Unassessed</i>	< 26
<i>Low</i>	≥ 26 and < 50
<i>Medium</i>	≥ 50 and < 75
<i>High</i>	≥ 75 and < 90
<i>Very High</i>	≥ 90 and <99
<i>Extreme</i>	≥ 99 and <100

The MWTR system is developed to assess long-term changes in wildfire patterns throughout California and to identify differences that existed between specific regions and periods of analysis, we deemed the inclusion of cells with null and zero estimate values during the determination of percentile break values to be desirable. Of the 10,688 16th degree latitude x 16th longitude prediction cells required to provide full coverage of California's extent, 1094 cells (10.24%) produced estimates that are all equal to zero or null during the entire period modeled (1953-2100). Many of these areas are likely masked out of the results by Westerling (forthcoming). The period median estimates for such cells are set to zero and assigned the MWTR thematic classification of "Little to None or Unassessed." This is done after observing that many of these cells capture locations in California where it is highly unlikely, if not impossible, for wildfires to occur due to a lack of combustible wildland fire fuel presence during the reference period (**Figure D 14**). Highly developed areas, like downtown Los Angeles, which has a high concentration of impervious surfaces, are places where the threat of large wildfire is non-existent. Agricultural lands, concentrated in the Central Valley, are also places where a large wildfire could not have become established. Zero or null estimates of area burned by wildfire existed in Westerling's (forthcoming) modeling outputs where pixels contain large water bodies or stretches of barren land. By choosing to include the zeros and null values as zeros in the set from which percentile range values are identified, MWTR provides a classification system that takes all areas of the State into account and not just those where large wildfire has been predicted to occur during the reference period.

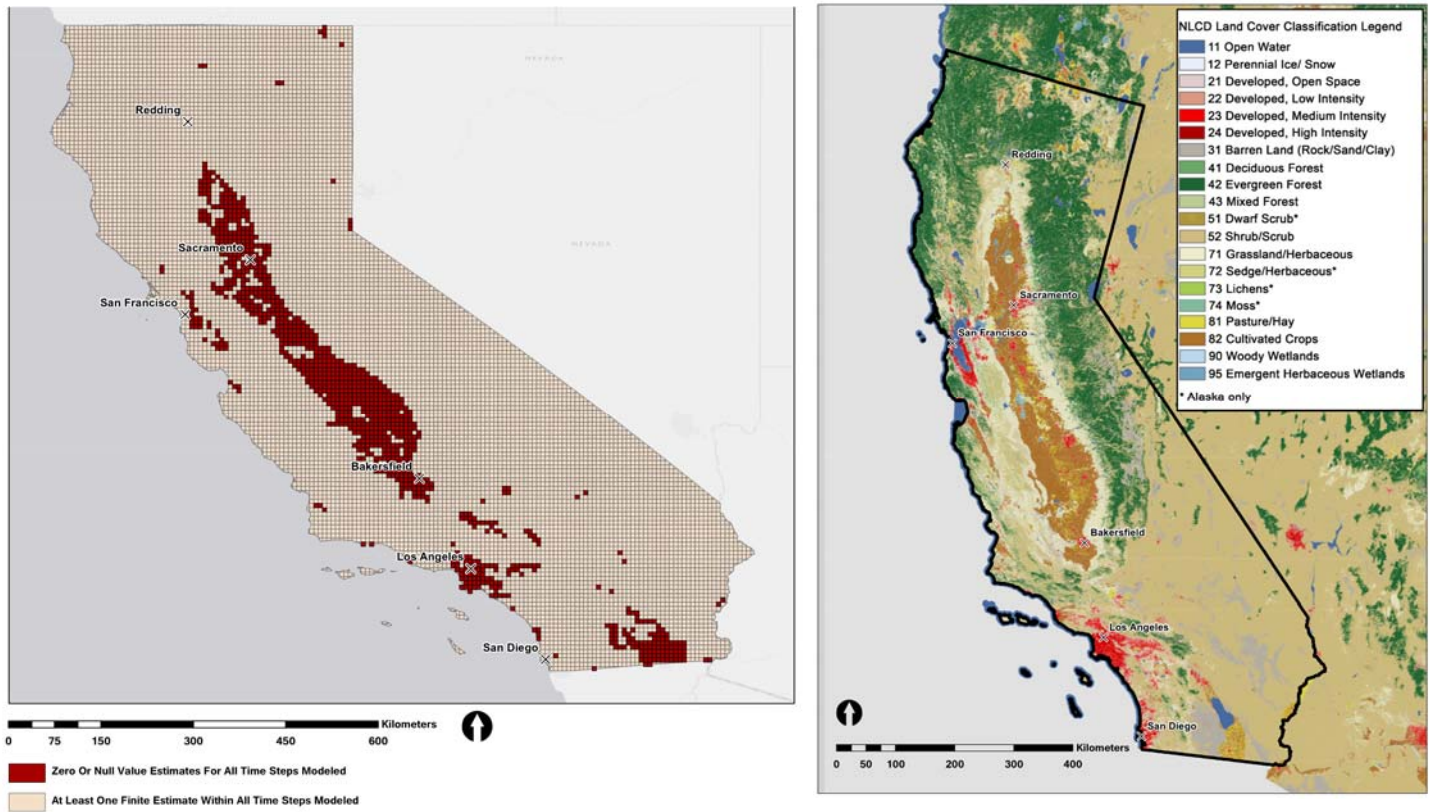

Figure D 14. Prediction cells with only zero or null value estimates were produced in red (Left). Areas which had at least one estimate of area burned by wildfire that is greater than zero throughout all of the time steps modeled between 1953-2100 is in yellow (Left). The NLCD classified map of California and portions of Nevada are also shown (Right). Placing map graphics of these two datasets side-by-side allows one to see that many of the cells that had all zero or null estimate values are found in areas where wildland fuels are determined to be either entirely or mostly absent or broken up in such a manner that a large wildfire would not be possible.

In an attempt to investigate the role that RCP selection plays on modeled projections of wildfire, MWTR percentile breaks are determined using three subsets of MEV values including all outputs from RCP 4.5 and RCP 8.5 scenarios, outputs from just the RCP 8.5 scenarios, and outputs just from the RCP 4.5 scenarios. Median, Maximum, and Minimum MEV percentile break values derived from these sets of values are quite comparable during the Reference Period (**Table D 3**). Which is to be expected given initial conditions for the emissions' pathways modeled were similar.

Table D 3. Median, Minimum, and Maximum MEV percentile break values for the 2000-2020 reference period. Break values were determined using (a) all outputs from RCP 4.5 and RCP 8.5 scenarios, (b) outputs from just the RCP 8.5 scenarios, and (c) outputs just from the RCP 4.5 scenarios.

Percentile Break	Median MEV for Reference Period (2000-2020)			Minimum MEV for Reference Period (2000-2020)			Maximum MEV for Reference Period (2000-2020)		
	(a.) RCP 8.5 and 4.5	(b.) RCP 8.5	(c.) RCP4.5	(a.) RCP 8.5 and 4.5	(b.) RCP 8.5	(c.) RCP4.5	(a.) RCP 8.5 and 4.5	(b.) RCP 8.5	(c.) RCP4.5
26th*	2	2	2	0	0	0	18	16	17
50th	14	14	14	0	0	0	54	50.5	50
75th	27	28	27	3	4	5	93	88	86
90th	36.5	36.5	37	9	10	11	147	139	135
99th	60	59	61	21	22	25	873.13	872.13	833.13
100th	80	86.5	78	32	34	45	1638	1638	1577

*27th percentile value reported for Median MEV value determined using only estimates from RCP 8.5 wildfire projection scenarios modeled

The results shown in **Figure D 15** imply that 99th percentile estimate of area burned by wildfire during the current period has a higher likelihood of being observed during future periods, particularly in the last 20 years of the century. The top and middle figures of Figure D 15 appear almost identical. The bottom seems to be identical to the top two figures until the 2080-2100 period. At that time there are differences in the Sierra Mountains - probably because it only uses RCP 4.5.

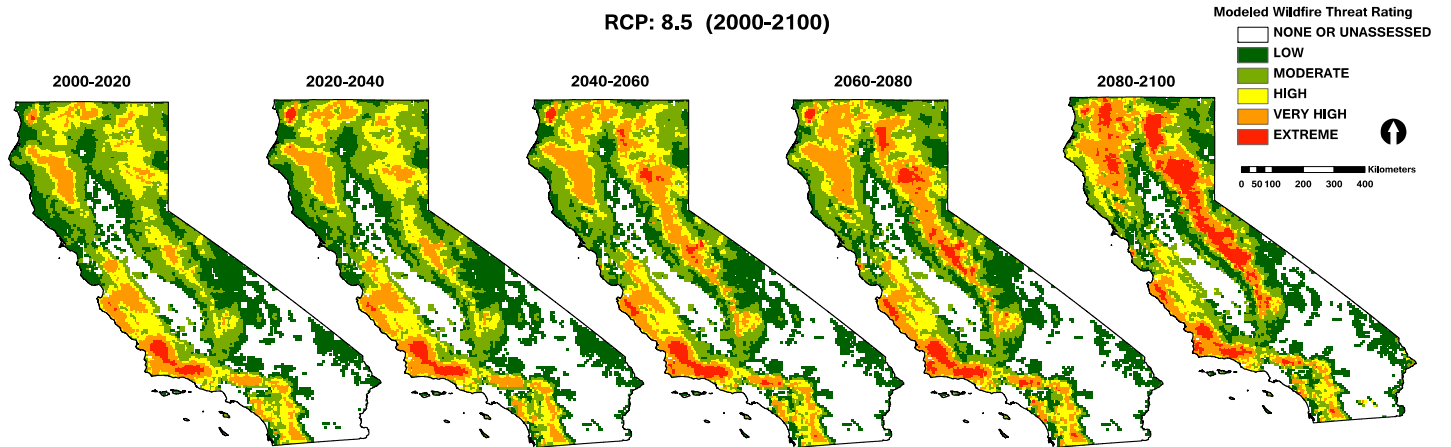
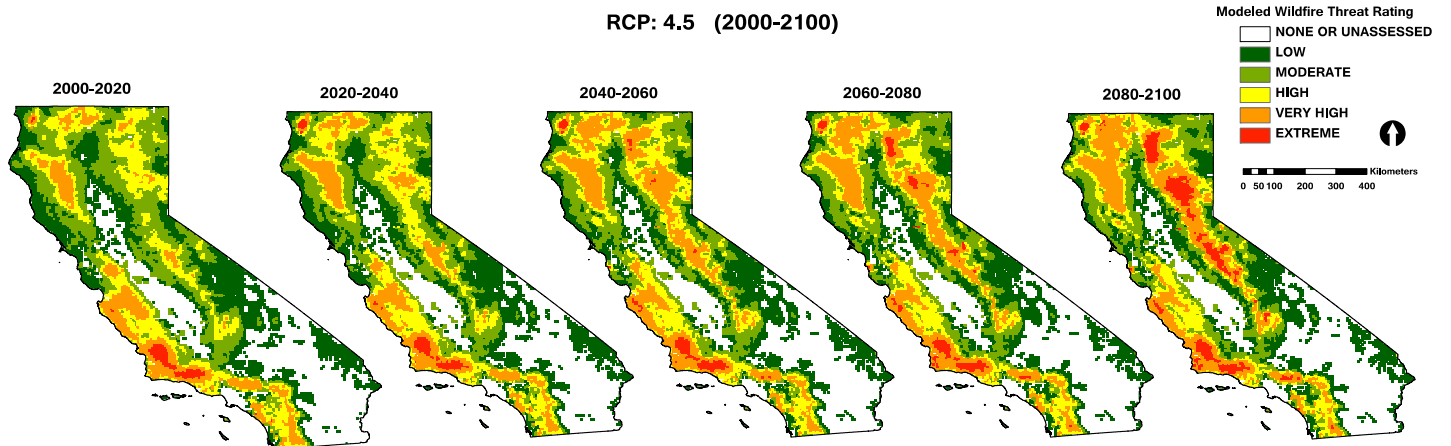
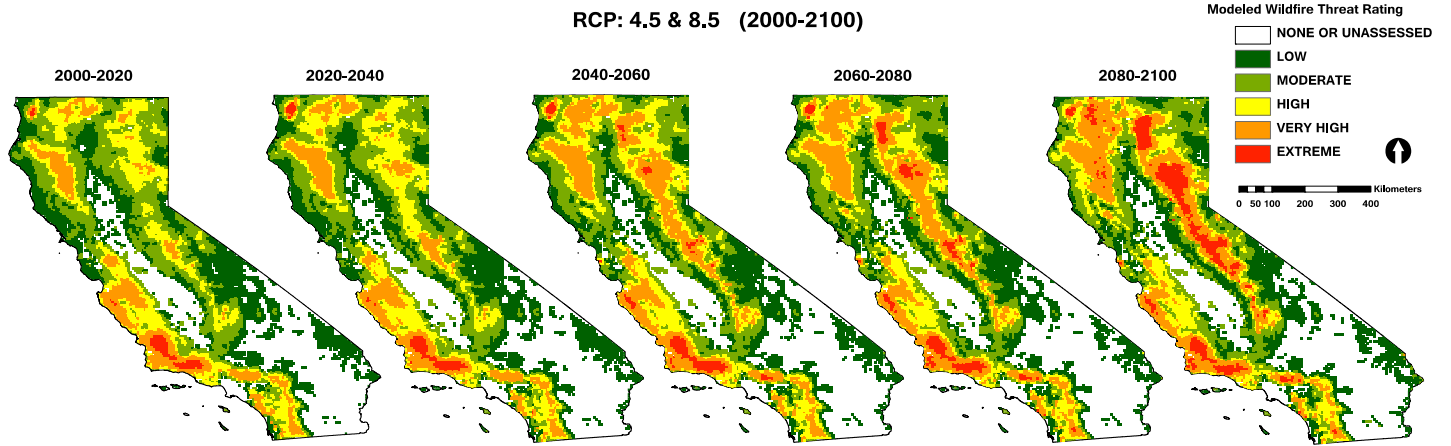

Figure D 15: Present-day and future Modeled Wildfire Threat Rankings (MWTR) for twenty-year long periods falling between 2000 to 2100. (Top) The pool of values used to calculate median estimate of area burned by wildfire annually for each prediction cell (16th Degree Latitude x 16th Degree Longitude; 3.85 mile x 3.85 mile resolution) included modeling outputs from all GCM's+RCP (8.5 and 4.5) +LULCcond projection scenarios. (Middle) The pool of values used to calculate median estimate of area

burned by wildfire annually for each prediction cell (16th Degree Latitude x 16th Degree Longitude; 3.85 mile x 3.85 mile resolution) included modeling outputs from all GCM's+RCP (8.5 only) +LULCcond projection scenarios. (Bottom) The pool of values used to calculate median estimate of area burned by wildfire annually for each prediction cell (16th Degree Latitude x 16th Degree Longitude; 3.85 mile x 3.85 mile resolution) included modeling outputs from all GCM's+RCP (4.5 only) +LULCcond projection scenarios. Prediction cells having all null or zero value estimates are included in the construction of the (MWTR) system.

Much of the variability in the frequency, magnitude, and severity of wildfires that have been projected to take place in California can be explained by differences in the types of vegetation, or fuels, that carry wildfires. The State's total wildfire diversity can be segmented into the broad, but extremely intuitive dominant vegetation-based categorizations of wildfire. The most basic form of this type of classification system involves labeling sub-regions as being dominated by grass fire, shrub fire, and forest fire. Although the descriptions of these three types of wildfire lack precision, they often prove to be the best way to communicate basic differences in wildfires observed through the State to individuals with limited exposure to wildfire science and management.

Stratification of California's wildfire prone areas can also be achieved through the use of slightly more descriptive land cover typologies than those that only discriminate between grass, shrub, and forest classifications. The 2010 California Fire Plan (CFP), which was updated and re-released in April of 2016 (CDF-FRAP 2015) divided up the State in terms of the dominant vegetative life form found in each area for the purpose of summarizing the amount of area burned by wildfire in each of these classes over time (**Figure D 3**). The CFP authors label vegetated areas as conifer, hardwood, herbaceous, shrubland, or agriculture dominant. Shrublands are found to have experienced the greatest amount of area burned by wildfire during each of the decadal periods summarized between 1950 and 2008. The CFP also determined that more acres of conifer forest burned than hardwood forest during this same time span. Agricultural areas experienced the smallest area burned on average while herbaceous, or grass dominated systems saw approximately twenty-five and fifty thousand acres of wildfire each year on average for each of the six decades assessed. The land cover classifications used in the CFP helped to summarize findings of historical fire analyses in a manner that can be understood by most non-technical audiences.

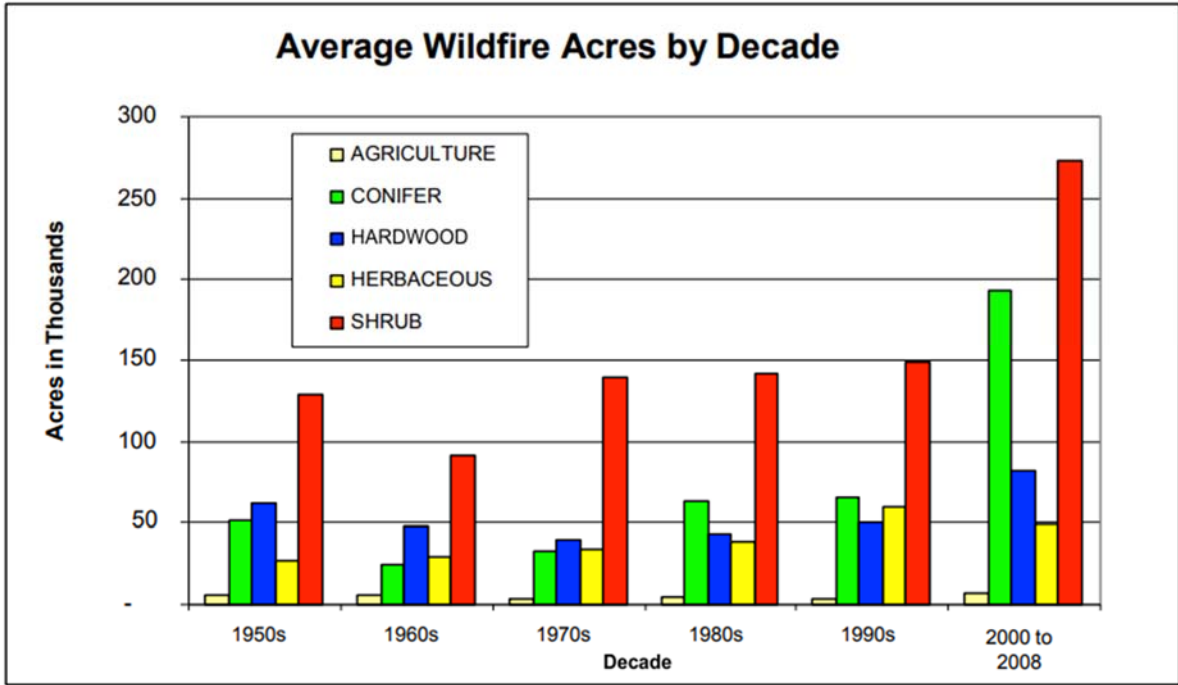
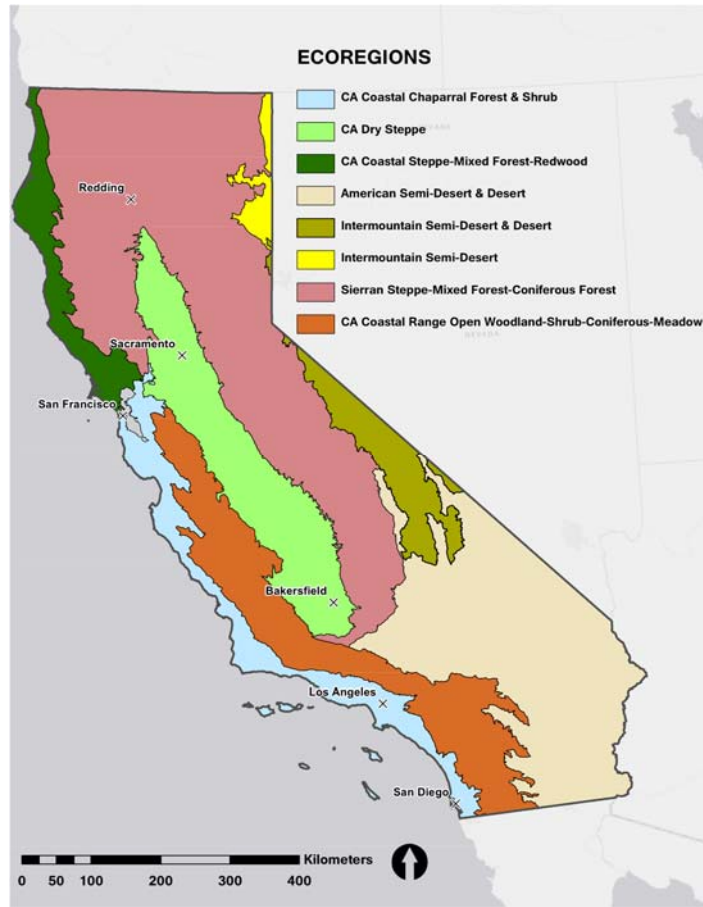

Figure D 16. Decadal averages of mean area burned by wildfire annually for six periods falling between 1950 and 2008. All periods except the 2000-2008 period represent ten-year averages of acres burned by wildfire in five different land cover types found in California. Figure reproduced from California Fire Plan (State Board of Forestry and Fire Protection, 2016).

Summarizing wildfire trends within and between simple descriptions of land cover works well when distinct land cover types can be found within an area of interest. The State of California can also be stratified, using non-jurisdictional boundaries that take other factors, such as climate or soil types, into account when classifying an area.

Figure D 17 provides an example of a classification system, which divides the State up using ten CALVEG EcoRegion Province boundaries that have been drawn by the U.S. Department of Agriculture -United States Forest Service. Segmenting the State into CALVEG EcoRegions also allows analysts to draw distinctions between multiple climate types (Cleland, Freeouf, Nowacki, Carpenter, & McNab, 2007).



CALVEG EcoRegion Province	% of State
<i>CA Coastal Chaparral Forest and Shrub</i>	6.6%
<i>CA Dry Steepe</i>	12.0%
<i>CA Coastal Steppe-Mixed Forest-Redwood Forest</i>	4.5%
<i>American Semi-Desert and Desert</i>	20.9%
<i>Intermountain Semi-Desert and Desert</i>	4.6%
<i>Intermountain Semi-Desert</i>	1.4%
<i>Sierran Steepe-Mixed Forest- Coniferous Forest-Alpine Meadow</i>	38.0%
<i>CA Coastal Range Open Woodland-Shrub-Coniferous-Forest-Meadow</i>	12.1%

Figure D 17. USDA-USFS Region 5 CALVEG EcoRegion Provinces found in California

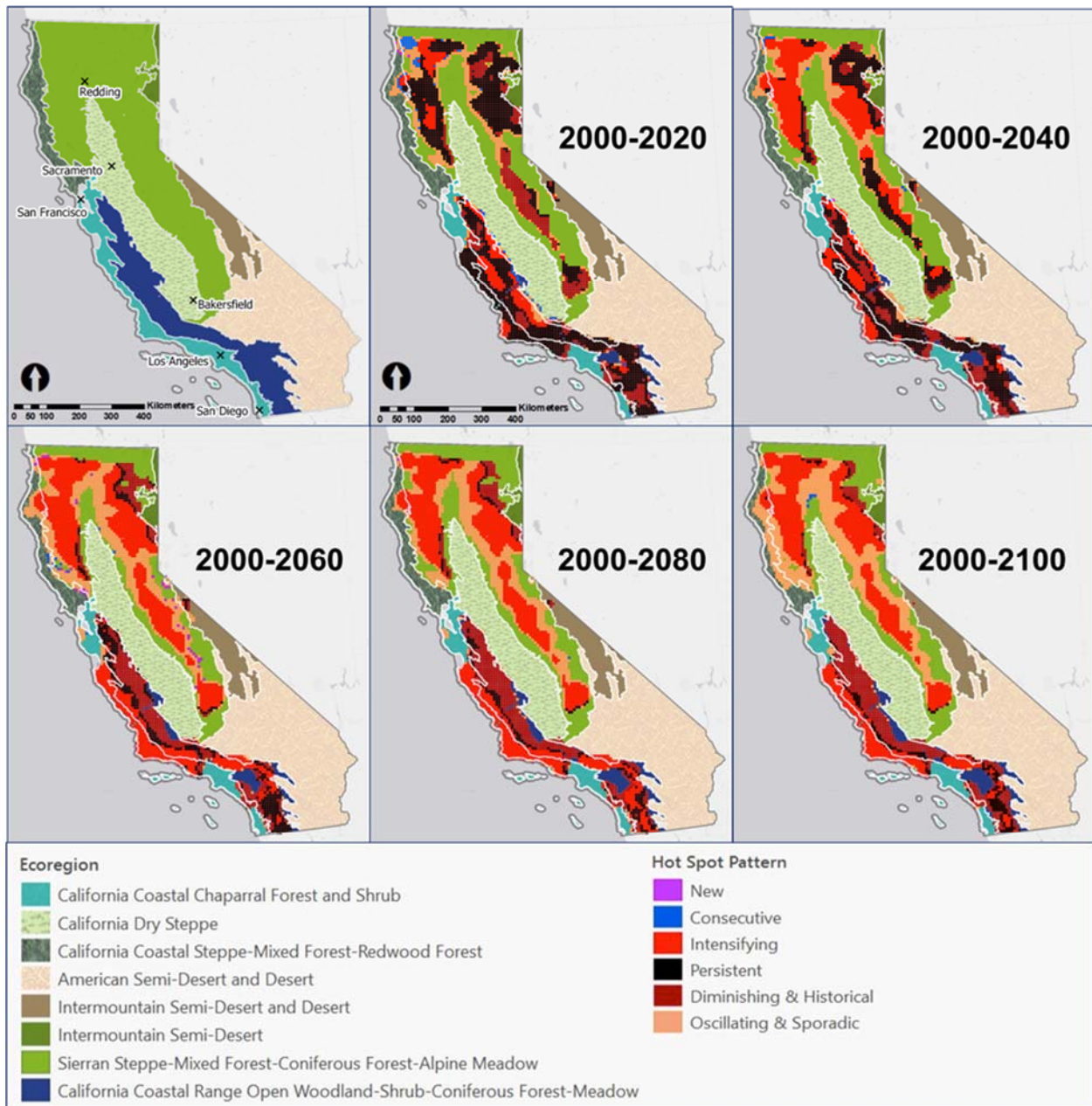

Figure D 18. ESRI ArcGIS Emerging Hot Spot Tool output maps and CALVEG EcoRegion Provinces

When we overlaid the results of our emerging hot spot analysis with CALVEG Ecoregion Provinces we noticed:

- Along the southern coast (areas around Big Sur) areas characterized by coastal chaparral forest and shrub are vulnerable in all time periods studied. These regions are affected by either Intensifying or Persistent hot spots.
- Sierran steppe-mixed forest coniferous forest–alpine meadows ecoregion province will be affected by persistent, diminishing, or intensifying hot spots (depending on the time period studied).

- The California Coastal Range Open Woodland Shrub Coniferous Forest Meadow is also an ecoregion that will largely experience Intensifying or Persistent hot spots.

In **Table D 4** we supply modeled Wildfire Threat Ratings for CALVEG EcoRegion Provinces. In **Figure D 19** this same information is summarized using bar graphs.

Table D 4. Modeled Wildfire Threat Ratings for CALVEG EcoRegion Provinces

Assessment Period	2000-2020					
Modeled Wildfire Threat Rating	None or Unassessed	Low	Moderate	High	Very High	Extreme
<i>CA Coastal Chaparral Forest and Shrub</i>	17.29%	17.25%	18.44%	17.17%	29.06%	0.79%
<i>CA Dry Steepe</i>	61.50%	20.57%	15.93%	1.94%	0.06%	0.00%
<i>CA Coastal Steppe-Mixed Forest-Redwood Forest</i>	2.83%	67.27%	23.53%	4.07%	2.30%	0.00%
<i>American Semi-Desert and Desert</i>	82.71%	15.07%	1.48%	0.45%	0.29%	0.00%
<i>Intermountain Semi-Desert and Desert</i>	20.88%	58.59%	16.81%	3.71%	0.00%	0.00%
<i>Intermountain Semi-Desert</i>	0.71%	43.56%	52.92%	2.81%	0.00%	0.00%
<i>Sierran Steepe-Mixed Forest- Coniferous Forest-Alpine Meadow</i>	1.37%	17.25%	45.67%	27.33%	8.26%	0.13%
<i>CA Coastal Range Open Woodland-Shrub-Coniferous-Forest-Meadow</i>	3.56%	5.03%	14.88%	36.31%	32.40%	7.82%
Assessment Period	2020-2040					
Modeled Wildfire Threat Rating	None or Unassessed	Low	Moderate	High	Very High	Extreme
<i>CA Coastal Chaparral Forest and Shrub</i>	18.10%	16.99%	19.08%	15.60%	28.95%	1.28%
<i>CA Dry Steepe</i>	61.50%	19.85%	16.58%	1.78%	0.28%	0.00%
<i>CA Coastal Steppe-Mixed Forest-Redwood Forest</i>	1.62%	59.67%	30.83%	3.04%	4.84%	0.00%
<i>American Semi-Desert and Desert</i>	81.97%	16.13%	1.16%	0.40%	0.35%	0.00%
<i>Intermountain Semi-Desert and Desert</i>	24.59%	55.47%	16.64%	3.30%	0.00%	0.00%
<i>Intermountain Semi-Desert</i>	1.41%	48.55%	47.76%	2.27%	0.00%	0.00%
<i>Sierran Steepe-Mixed Forest- Coniferous Forest-Alpine Meadow</i>	1.30%	16.37%	40.24%	28.64%	13.00%	0.45%
<i>CA Coastal Range Open Woodland-Shrub-Coniferous-Forest-Meadow</i>	3.80%	5.77%	14.04%	36.38%	31.77%	8.24%
Assessment Period	2040-2060					
Modeled Wildfire Threat Rating	None or Unassessed	Low	Moderate	High	Very High	Extreme
<i>CA Coastal Chaparral Forest and Shrub</i>	18.28%	14.56%	19.24%	14.81%	29.60%	3.52%
<i>CA Dry Steepe</i>	61.50%	21.40%	16.16%	0.91%	0.02%	0.00%
<i>CA Coastal Steppe-Mixed Forest-Redwood Forest</i>	1.39%	41.59%	44.82%	6.68%	5.52%	0.00%
<i>American Semi-Desert and Desert</i>	84.49%	13.60%	1.13%	0.30%	0.48%	0.00%
<i>Intermountain Semi-Desert and Desert</i>	31.15%	49.94%	14.98%	3.92%	0.00%	0.00%
<i>Intermountain Semi-Desert</i>	2.11%	55.09%	41.10%	1.70%	0.00%	0.00%
<i>Sierran Steepe-Mixed Forest- Coniferous Forest-Alpine Meadow</i>	1.01%	13.92%	32.94%	23.81%	26.88%	1.44%
<i>CA Coastal Range Open Woodland-Shrub-Coniferous-Forest-Meadow</i>	4.06%	6.75%	14.67%	36.31%	29.18%	9.04%
Assessment Period	2060-2080					
Modeled Wildfire Threat Rating	None or Unassessed	Low	Moderate	High	Very High	Extreme
<i>CA Coastal Chaparral Forest and Shrub</i>	18.45%	14.24%	18.34%	12.79%	30.32%	5.86%
<i>CA Dry Steepe</i>	61.58%	22.73%	15.04%	0.63%	0.02%	0.00%
<i>CA Coastal Steppe-Mixed Forest-Redwood Forest</i>	1.18%	33.96%	50.14%	9.02%	5.70%	0.00%
<i>American Semi-Desert and Desert</i>	87.34%	10.96%	0.89%	0.33%	0.47%	0.00%
<i>Intermountain Semi-Desert and Desert</i>	40.41%	43.07%	13.74%	2.70%	0.07%	0.00%
<i>Intermountain Semi-Desert</i>	11.22%	61.00%	27.70%	0.08%	0.00%	0.00%
<i>Sierran Steepe-Mixed Forest- Coniferous Forest-Alpine Meadow</i>	1.07%	14.95%	32.18%	20.38%	28.31%	3.12%
<i>CA Coastal Range Open Woodland-Shrub-Coniferous-Forest-Meadow</i>	4.81%	7.94%	17.02%	34.79%	26.88%	8.56%
Assessment Period	2080-2100					
Modeled Wildfire Threat Rating	None or Unassessed	Low	Moderate	High	Very High	Extreme
<i>CA Coastal Chaparral Forest and Shrub</i>	18.40%	13.66%	19.37%	13.50%	29.57%	5.50%
<i>CA Dry Steepe</i>	61.58%	22.69%	14.67%	1.04%	0.02%	0.00%
<i>CA Coastal Steppe-Mixed Forest-Redwood Forest</i>	0.62%	23.55%	52.50%	16.69%	6.64%	0.00%
<i>American Semi-Desert and Desert</i>	84.99%	12.84%	1.42%	0.32%	0.43%	0.00%
<i>Intermountain Semi-Desert and Desert</i>	43.68%	39.44%	14.03%	2.57%	0.28%	0.00%
<i>Intermountain Semi-Desert</i>	14.02%	63.93%	21.38%	0.66%	0.00%	0.00%
<i>Sierran Steepe-Mixed Forest- Coniferous Forest-Alpine Meadow</i>	0.90%	13.78%	27.43%	16.63%	29.84%	11.41%
<i>CA Coastal Range Open Woodland-Shrub-Coniferous-Forest-Meadow</i>	4.84%	9.15%	19.83%	36.05%	22.60%	7.53%

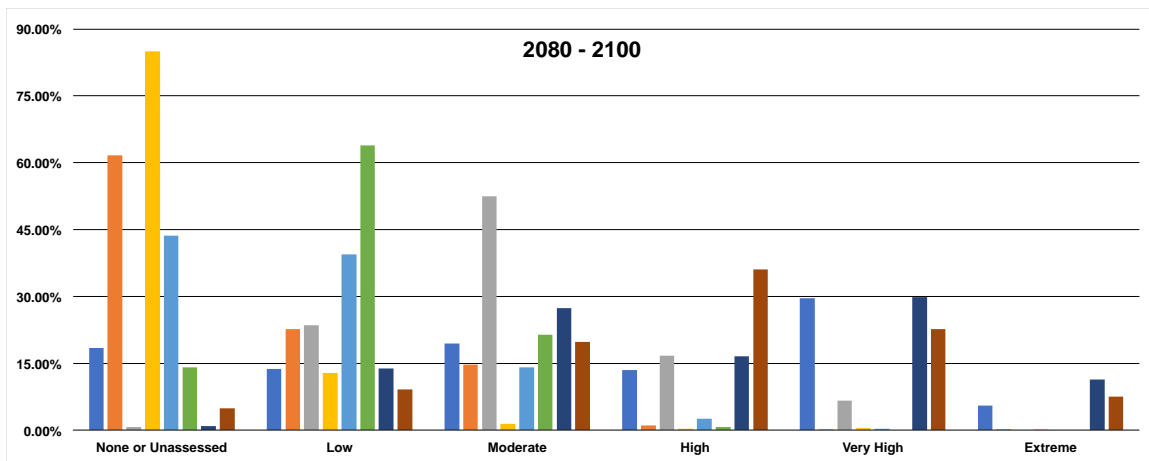
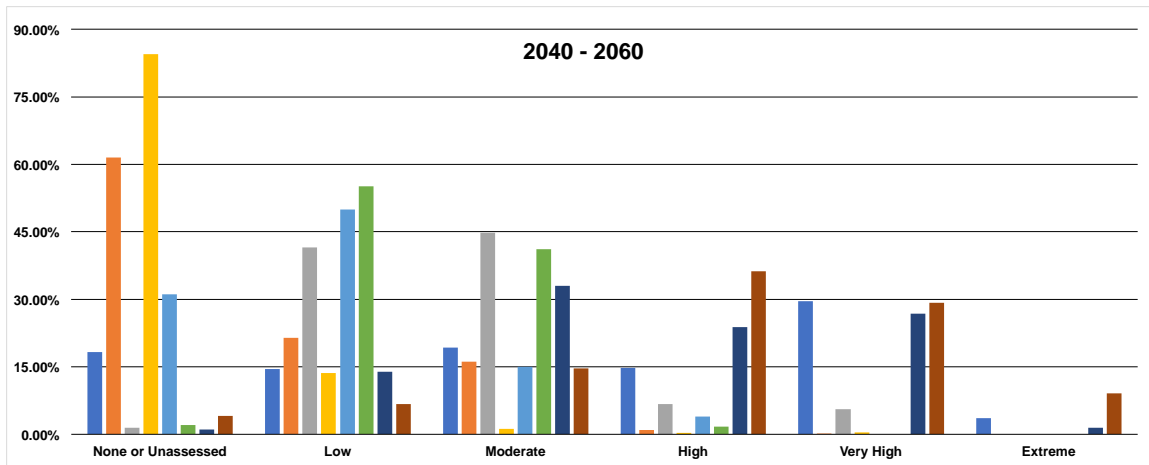
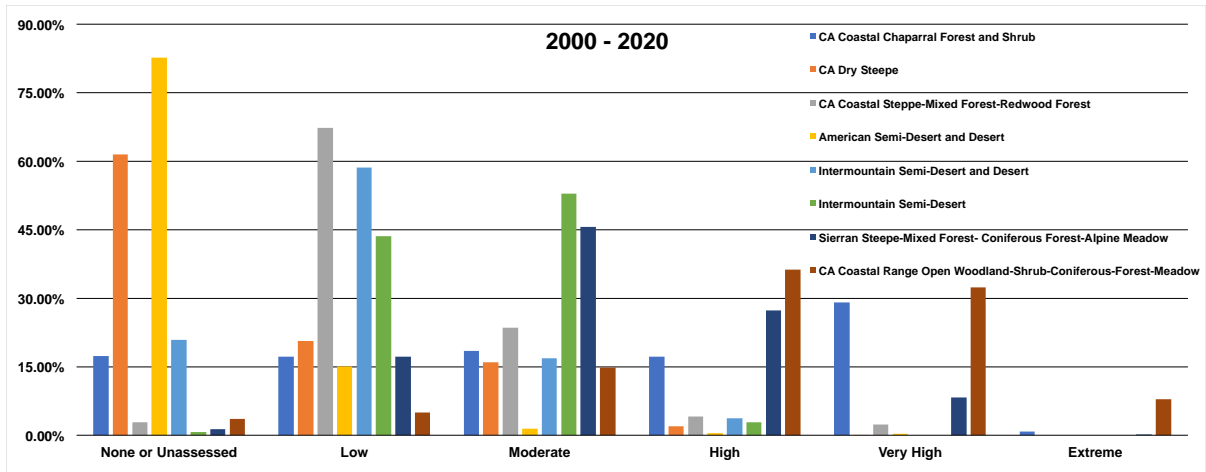

Figure D 19. Modeled Wildfire Threat Ratings for CALVEG EcoRegion Provinces. For the Reference Period (2000-2020) and two future periods: 2040 to 2060 and 2080 to 2100. All of the bars of a unique color correspond to one of The CALVEG EcoRegion Provinces

In certain instances, it may be highly desirable to assess wildfire variability using classification systems that decompose wildland areas using characterizations of the surface fuel beds. Surface fuels are defined as being either downed woody material, brush, or grass. Characteristics of surface fuel loads that contribute to fire behavior and fire severity include abundance, material size, and moisture content. The California Interagency Fuel Mapping Group (CAIFMG), a consortium of State and Federal agencies, maintains a regional surface fuel database that use definitions for the original standard 13 fuel behavior models (Anderson), used in the Fire Behavior Prediction System to classify areas of the State. The CAIFMG dataset is constructed from the "best available" wildland fuels data available for the State of California at the time of its most recent release in 2015 (California Department of Forestry and Fire Protection Fire and Resource Assessment Program, 2015).

D.2.7 Downscaling Westerling's Wildland Fire Futures to One Square Kilometer

Westerling's (forthcoming) regional-scale wildfire futures provide information that can prove to be too spatially coarse to be of great value to TFS stakeholders seeking to plan. Ultimately, many asset operators need a clearer picture of what is going on in each of Westerling's prediction cells if the modeling outputs are to be of any practical use. A 2018 USGS research project, headed up Dr. Ben Sleeter, downscaled Westerling's wildfire projections to one square km spatial resolution for a 100-year period spanning between 2001 and 2101 as part of an effort to estimate carbon balances over the remainder of the current century (B. Sleeter, Personal Communication, 2017). Sleeter's finer spatial resolution modeling outputs represent patterns of wildfire at the landscape scale and (may) better characterize wildfires where heterogeneous land cover types are found within a single 16th degree latitude x longitude Westerling prediction cell. To illustrate what this improvement in resolution means take, for example, a high elevation region of the southern Sierra Nevada where any one of Westerling's 16th degree latitude x longitude cells is likely to contain large, continuous areas of non-combustible granite rock as well as portions of flammable forest, grass, and shrub land cover types. In this situation Sleeter's downscaled wildfire modeling routine only burns portions of Westerling's larger cell classified as being a combustible cover type. However, fundamentally Sleeter and Westerling should be in agreement since Westerling's 16th degree latitude x longitude outputs are used to place limits on Sleeter's estimates of area burned by wildfire throughout different ecological regions of California. At the time of this project, Sleeter is in the process of publishing his approach to downscaling Westerling's results and further information on the results have been withheld at the researcher's request.

D.2.8 Application: Modeled Wildfire Threat Rating System and the TFS

For TFS link assets, including pipelines, highways, and rail lines, we define exposure to wildfire as the distance of the individual asset type intersecting the different MWTR categorizations. For TFS assets that have "footprints", such as oil fields, we calculate wildfire exposure in terms of the area falling in each MWTR classification. Other TFS assets in our analysis are defined by points (latitude and longitude coordinates) and in these instances we calculate wildfire exposure as counts of these assets across the different MWTR classes. This latter method is used to summarize exposure for Refinery, Terminal, Airport, and Gas Station TFS asset types. We do not assess changes in MWTR for Dock or Port type TFS assets, as is done in the flooding portion of this study, because the likelihood of a large wildfire occurring in the highly developed and water-rich areas of the State where they are located is essentially zero. For more information on all asset types assessed as well as data sources used to build the GIS layers for each asset

type, refer to Appendix A. The different asset types intersected with modeled wildfire futures can be found in **Table D 5**.

Table D 5. TFS asset types, geospatial vector data types, and units of analysis used when assessing exposure of asset type to different wildfire hazard and threat classes

TFS Asset Type[MSP1]	Vector Data Type	Unit of Analysis
Refineries	point	Counts
Terminals	point	Counts
Pipelines	polyline	Linear Distance in Miles
Rail	polyline	Linear Distance in Miles
Roadways	polyline	Linear Distance in Miles
Airports	polyline	Counts
Gas Stations	point	Counts
Oil Fields	polygon	Area in Hectares

Table D 6.Total distance, area, or number of TFS assets exposed to each Modeled Wildfire Hazard Rating (MWHR) class. Median values used to determine MWHR classes are taken from wildfire projections derived from the outputs of four GCMs (Warm/Dry, Cool/Wet, Average, and Complementary) run under two emissions scenarios (RCP 4.5 and RCP 8.5).

Assessment Period	2000-2020					
Modeled Wildfire Hazard Rating	None or Unassessed	Low	Moderate	High	Very High	Extreme
Refineries (Count)	12	4	2	0	0	0
Terminals (Count)	67	25	5	0	0	0
Pipelines (Miles)	3713.8	887.0	1561.1	772.4	322.6	23.8
Rail (Miles)	2188.3	968.2	758.8	452.2	191.7	0.0
Roadways (Miles)	4311.0	3642.6	3504.0	1982.8	1100.9	76.0
Airports (Count)	83	55	40	21	8	0
Gas Stations (Count)	6814	3289	1979	769	310	1
Oil Fields (Hectares)	139353.1	61007.8	78418.8	34374.3	20472.1	191.1
Assessment Period	2020-2040					
Modeled Wildfire Hazard Rating	None or Unassessed	Low	Moderate	High	Very High	Extreme
Refineries (Count)	12	4	2	0	0	0
Terminals (Count)	67	25	5	0	0	0
Pipelines (Miles)	3727.1	882.9	1553.0	764.8	324.2	28.6
Rail (Miles)	2191.1	1024.9	648.6	401.3	293.2	0.0
Roadways (Miles)	4310.7	3581.9	3445.9	1977.4	1207.9	93.5
Airports (Count)	84	53	43	17	10	0
Gas Stations (Count)	6902	3515	1778	680	281	6
Oil Fields (Hectares)	140560.2	57099.0	78820.0	35288.5	21270.5	778.8
Assessment Period	2040-2060					
Modeled Wildfire Hazard Rating	None or Unassessed	Low	Moderate	High	Very High	Extreme
Refineries (Count)	12	4	2	0	0	0
Terminals (Count)	71	22	4	0	0	0
Pipelines (Miles)	3760.0	1165.2	1437.0	526.4	357.9	34.2
Rail (Miles)	2240.3	971.8	635.9	318.7	373.6	18.9
Roadways (Miles)	4400.0	3263.6	3265.5	1807.1	1732.9	148.2
Airports (Count)	83	52	41	16	15	0
Gas Stations (Count)	7038	3478	1653	596	383	14
Oil Fields (Hectares)	140560.2	72143.8	80686.3	19320.9	18293.9	2811.9
Assessment Period	2060-2080					
Modeled Wildfire Hazard Rating	None or Unassessed	Low	Moderate	High	Very High	Extreme
Refineries (Count)	12	4	2	0	0	0
Terminals (Count)	71	23	2	1	0	0
Pipelines (Miles)	3803.9	1283.6	1393.7	389.3	335.7	74.5
Rail (Miles)	2295.1	973.6	607.5	301.4	312.9	68.6
Roadways (Miles)	4519.7	3250.1	3172.2	1638.8	1789.3	247.1
Airports (Count)	83	52	39	17	14	2
Gas Stations (Count)	7117	3582	1424	561	437	41
Oil Fields (Hectares)	140560.2	83598.7	74580.2	13118.7	17012.0	4947.2
Assessment Period	2080-2100					
Modeled Wildfire Hazard Rating	None or Unassessed	Low	Moderate	High	Very High	Extreme
Refineries (Count)	12	5	1	0	0	0
Terminals (Count)	71	23	3	0	0	0
Pipelines (Miles)	3801.5	1305.9	1398.5	374.0	321.6	79.2
Rail (Miles)	2321.5	948.3	592.8	284.4	283.5	128.7
Roadways (Miles)	4511.7	3207.7	3045.2	1552.9	1821.3	478.6
Airports (Count)	84	49	40	17	13	4
Gas Stations (Count)	7125	3628	1421	522	362	104
Oil Fields (Hectares)	140560.2	84078.1	73654.7	15211.8	15403.0	4909.3

Table D 7. Percentage of each TFS asset type exposed to each MWHR class. Median values used to determine MWHR class were taken from wildfire backcast and forecast data derived from the outputs of four GCMs (Warm/Dry, Cool/Wet, Average, and Complementary) run under two emissions scenarios (RCPs 4.5 and 8.5).

Assessment Period	2000-2020					
Modeled Wildfire Hazard Rating	None or Unassessed	Low	Moderate	High	Very High	Extreme
Refineries (%)	66.67	22.22	11.11	0.00	0.00	0.00
Terminals (%)	69.07	25.77	5.15	0.00	0.00	0.00
Pipelines (%)	51.01	12.18	21.44	10.61	4.43	0.33
Rail (%)	48.00	21.24	16.64	9.92	4.20	0.00
Roadways (%)	29.49	24.92	23.97	13.56	7.53	0.52
Airports (%)	40.10	26.57	19.32	10.14	3.86	0.00
Gas Stations (%)	51.77	24.99	15.04	5.84	2.36	0.01
Oil Fields (%)	41.75	18.28	23.49	10.30	6.13	0.06
Assessment Period	2020-2040					
Modeled Wildfire Hazard Rating	None or Unassessed	Low	Moderate	High	Very High	Extreme
Refineries (%)	66.67	22.22	11.11	0.00	0.00	0.00
Terminals (%)	69.07	25.77	5.15	0.00	0.00	0.00
Pipelines (%)	51.19	12.13	21.33	10.50	4.45	0.39
Rail (%)	48.06	22.48	14.23	8.80	6.43	0.00
Roadways (%)	29.49	24.50	23.57	13.53	8.26	0.64
Airports (%)	40.58	25.60	20.77	8.21	4.83	0.00
Gas Stations (%)	52.44	26.71	13.51	5.17	2.13	0.05
Oil Fields (%)	42.11	17.10	23.61	10.57	6.37	0.23
Assessment Period	2040-2060					
Modeled Wildfire Hazard Rating	None or Unassessed	Low	Moderate	High	Very High	Extreme
Refineries (%)	66.67	22.22	11.11	0.00	0.00	0.00
Terminals (%)	73.20	22.68	4.12	0.00	0.00	0.00
Pipelines (%)	51.64	16.00	19.74	7.23	4.92	0.47
Rail (%)	49.14	21.32	13.95	6.99	8.19	0.41
Roadways (%)	30.10	22.33	22.34	12.36	11.86	1.01
Airports (%)	40.10	25.12	19.81	7.73	7.25	0.00
Gas Stations (%)	53.47	26.42	12.56	4.53	2.91	0.11
Oil Fields (%)	42.11	21.61	24.17	5.79	5.48	0.84
Assessment Period	2060-2080					
Modeled Wildfire Hazard Rating	None or Unassessed	Low	Moderate	High	Very High	Extreme
Refineries (%)	66.67	22.22	11.11	0.00	0.00	0.00
Terminals (%)	73.20	23.71	2.06	1.03	0.00	0.00
Pipelines (%)	52.25	17.63	19.14	5.35	4.61	1.02
Rail (%)	50.34	21.36	13.33	6.61	6.86	1.51
Roadways (%)	30.92	22.23	21.70	11.21	12.24	1.69
Airports (%)	40.10	25.12	18.84	8.21	6.76	0.97
Gas Stations (%)	54.07	27.21	10.82	4.26	3.32	0.31
Oil Fields (%)	42.11	25.04	22.34	3.93	5.10	1.48
Assessment Period	2080-2100					
Modeled Wildfire Hazard Rating	None or Unassessed	Low	Moderate	High	Very High	Extreme
Refineries (%)	66.67	27.78	5.56	0.00	0.00	0.00
Terminals (%)	73.20	23.71	3.09	0.00	0.00	0.00
Pipelines (%)	52.21	17.94	19.21	5.14	4.42	1.09
Rail (%)	50.92	20.80	13.00	6.24	6.22	2.82
Roadways (%)	30.87	21.94	20.83	10.62	12.46	3.27
Airports (%)	40.58	23.67	19.32	8.21	6.28	1.93
Gas Stations (%)	54.13	27.56	10.80	3.97	2.75	0.79
Oil Fields (%)	42.11	25.19	22.06	4.56	4.61	1.47

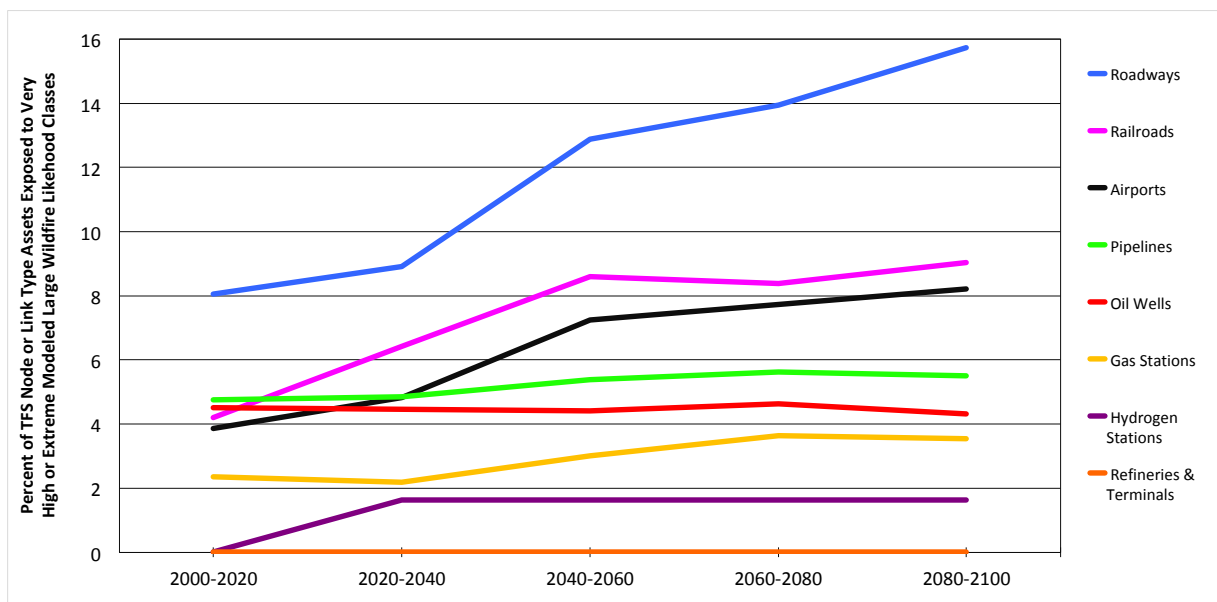

Figure D 20. Percentages of each TFS asset types exposed to Very High or Extreme MWTR classes during each 20-year period of analysis. Note that Refineries and Terminals carry no Very High or Extreme MWTR exposure during the entire one-hundred year time-frame assessed and thus have slopes of 0 and intersect the y-axis at 0 on the chart.

During the 2000-2100 period we expect marked increases to occur in the percentages of highways (+ 8% of total distance), Railways (+ 5% of total distance), Airports (+ 4% of total number) that intersect areas of the State with MWTR classifications that are Very High or Extreme (**Figure D 20**). Less dramatic increases in the percentages of Pipelines (+ 1% of total length) and Gas Stations (+ 2% of total count) with exposure the two most severe MWTR classes are expected during the same one-hundred year timeframe. Oilfields show a slight decrease (<1%) in exposure to Very High or Extreme MWTR classes while Refineries and Terminals carry no Very High or Extreme MWTR exposure during the entire century-long assessment period.

The majority of each TFS asset type is located in regions of the State where the 90th percentile or greater median estimate for area burned by wildfire annually during the reference period (2000-2020) is not been projected to occur in the future. Many TFS asset containing regions of the State carry Low, Moderate, or High MWTR throughout the 21st century and still have potential to be exposed to large wildfire events (**Figure D 21**). Terminals and Refineries are exposed to very small amounts of large wildfire relative the other asset types however the threat still exists and is projected to persist.

■ Low
 ■ Moderate
 ■ High
 ■ Very High
 ■ Extreme

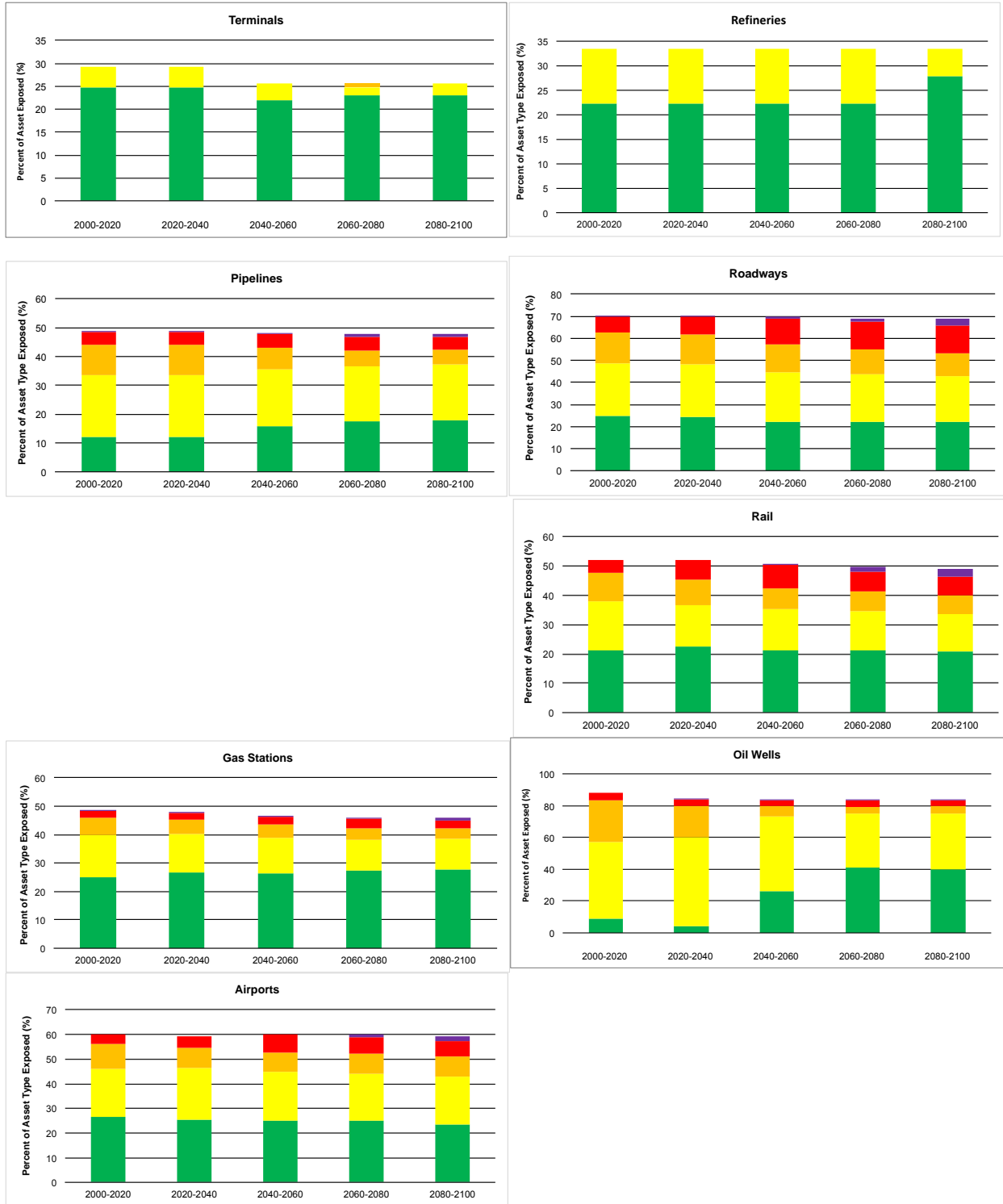

Figure D 21. Percentage of each TFS asset type exposed to each MWTR class.

Pipelines that carry refined products are of particular interest to TFS stakeholders for reasons discussed in the main body of this document. **Figure D 22** shows TFS non-crude pipelines overlaid upon the results of the space-time hotspot analysis. Areas around the Salton Sea are projected to have intensifying hotspots over the century.

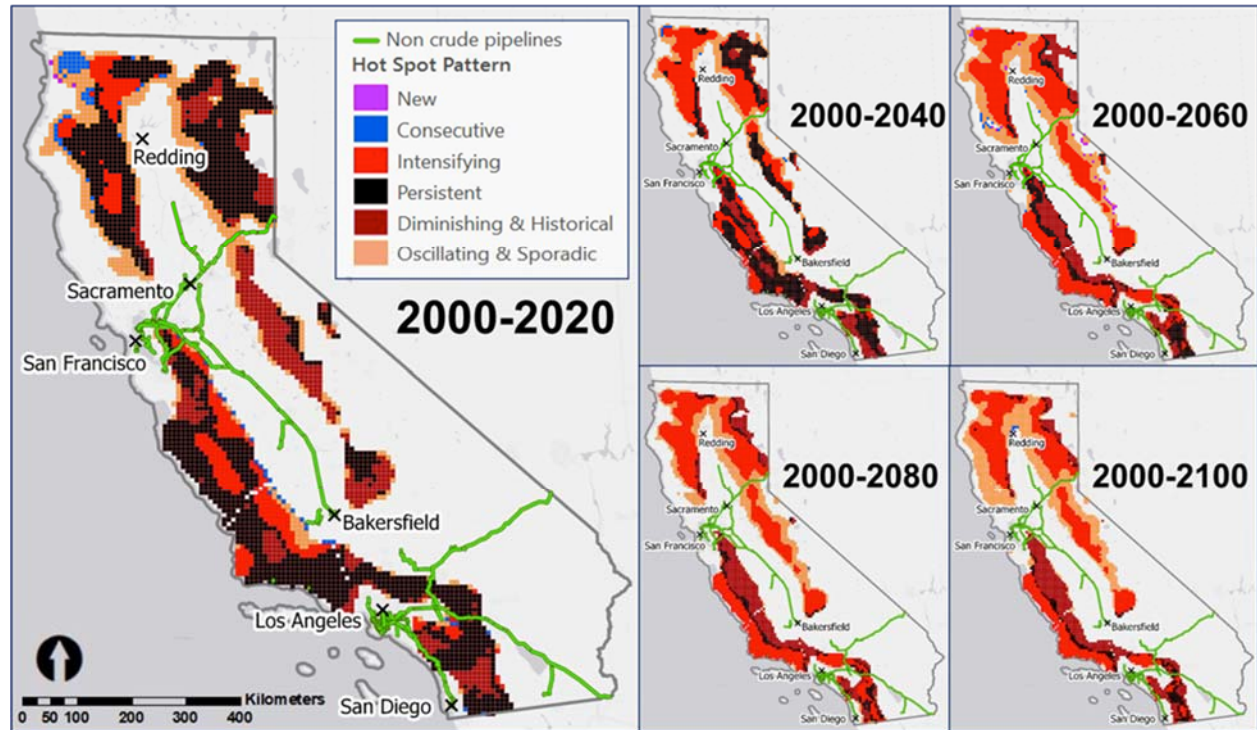

Figure D 22. Statewide hot spot areas and non-crude pipelines

So far this Appendix has explored future projections of statewide wildfire threat across different models, examined spatial-temporal trends in statewide modelled wildfire occurrence, compared existing modelling techniques, and assessed the wildfire threat of the essential TFS. Dr. Westerling’s wildfire projection dataset is used to identify areas with a high potential of being affected by wildfire - hot spot areas. The following section focuses on describing the newly created methodology that models wildfire behavior at a fine spatial scale (5-m; 16.4-ft) resolution. Modeling techniques, data collection methods and challenges, and future directions are further discussed.

D.2.9 Tree Mortality and Wildfire

Recent research by Stephens et al. (2018) reports that tree mortality is becoming more prevalent in California, especially in the northern California Sierra Nevada. The mortality is a result of recent drought, insects and disease, and a human-induced infrequency of low and moderate intensity wildfires. Downed vegetative fuels pose a risk of high and extreme surface fire intensity if ignited (Stephens et al., 2018). Moreover, they pose a risk of spotting, causing multiple proximate ignitions and potentially mass fire conditions (Collins, Personal Communication 2018). Dead standing trees pose threat of increased ignitability, but tree mortality proves most dangerous when these trees eventually fall to the forest floor, typically

about a decade after standing dead. The dead biomass on the forest floor poses the greatest threat of extreme surface fire intensity for multiple decades, after which the downed vegetation will have decomposed into non-ignitable biomass (Stephens et al., 2018).

We conducted research to identify wildfire hazards in California posed by tree mortality. In order to spatially locate hazard from tree mortality, a dataset is produced to identify canopy biomass loss in forests using remotely sensed MODIS imagery (Li, Under Review). The Biomass Loss dataset (see **Figure D 23**) leverages the Enhanced Vegetation Index (EVI) to indicate canopy biomass loss. Biomass loss is derived from decreases in seasonal peak canopy greenness from 2000 to 2016. Since remotely sensed imagery can only observe forest canopy, not understory, the dataset is interpreted as canopy biomass loss. The dataset is restricted to assess only forested regions by using forested land covers identified by the National Land Cover Database (NLCD) as a mask for the data. In addition to removing non-forested regions from the dataset, historical wildfires and clear cutting, acquired as polygons from GeoMAC and USFS, respectively, are removed from the dataset to eliminate biomass losses that do not contribute to combustible vegetation.

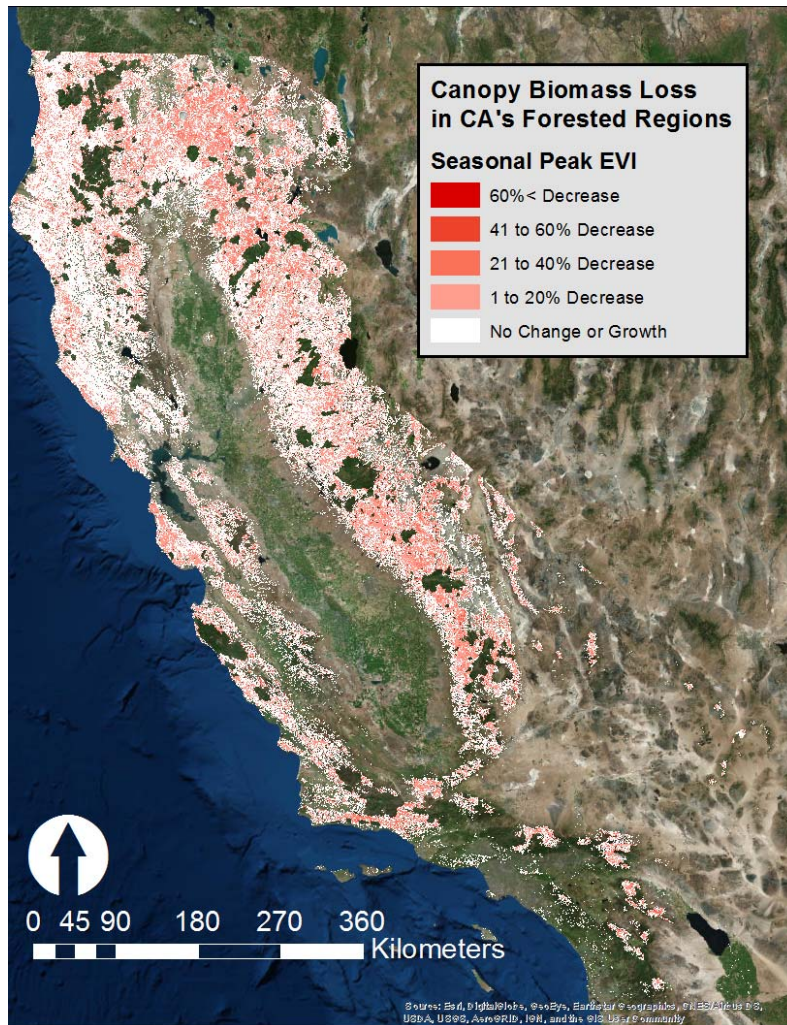

Figure D 23. 2000-2016 canopy biomass loss (as derived from decrease in seasonal peak EVI) in forested regions in California. The dataset tracks change in EVI from 2000 to 2016. Wildfires and locations of clearcutting are removed from the dataset.

Table D 8 displays where infrastructures are exposed to biomass loss, or where infrastructures intersect decreases in seasonal peak EVI during the observed time period. Considering only forested areas are assessed by the BML dataset, the first column shows the amount of infrastructure that does not intersect with a forested area, and therefore is excluded from the dataset. The next column, "No BML," indicates infrastructure exposed to seasonal peak EVI that either increases or is constant across the assessed time period. The following columns show the infrastructures exposed to decreases in seasonal peak EVI, or canopy biomass loss. These are areas of potential concern for the high- and extreme-surface fire intensities described by Stephens et al. (2018).

Table D 8. Total distance, area, or number of TFS assets exposed to biomass loss. Only forested areas are assessed by the biomass loss dataset, so “Not Forested” areas are separated from areas in forested regions. Of the forested regions, the table shows the exposure to increments of percentage decreases in canopy biomass loss, as well as “No Biomass Loss (BML).” The bin 81-100% is not included because there are no instances of this degree of canopy biomass loss intersecting with infrastructure.

Biomass Loss (% Decrease Seasonal Peak EVI)						
	Not Forested	No BML	1-20%	21-40%	41-60%	61-80%
Refineries (Count)	18	0	0	0	0	0
Terminals (Count)	96	1	0	0	0	0
Pipelines (Miles)	6,934.9	273.5	55.4	16.2	0.6	0
Rail (Miles)	3,988.0	403.6	148.1	17.9	1.6	0
Roadways (Miles)	11,012.1	2616.4	814.1	170.8	4.0	0.2
Airports (Count)	195	10	2	0	0	0
Gas Stations (Count)	12,675	398	78	11	0	0
Oil Fields (Hectares)	321,946.7	9,976.3	1,192.8	653.2	43.0	5.4

Of the infrastructures exposed to biomass loss, not all the infrastructures are in wildfire prone regions of the State. In order to decompose this data further, the infrastructures exposed to biomass loss--infrastructures described by the four rightmost columns above--are intersected with CAL FIRE Wildfire Rotation, a component of the CAL FIRE Threat Map (California Department of Forestry and Fire Protection Fire and Resource Assessment Program, 2015).

Table D 9 informs which infrastructures exposed to canopy biomass loss are also in regions that are expected to experience frequent wildfires.

Table D 9. Total distance, area, or number of TFS assets exposed to each class of wildfire rotation for each class of biomass loss.

Wildfire Rotation Interval	Canopy Biomass Loss	Pipeline (Miles)	Rail (Miles)	Gas Stations (Count)	Oil Fields (Hectares)	Roadways (Count)
None	1-20%	4.1	23.7	39	53.3	119.1
	21-40%	2.1	2.2	5	64.0	30.2
	41-60%	0.2	0	0	6.1	0.9
	61-80%	0	0	0	0	0
Low (>200 years)	1-20%	6.3	7.0	3	96.3	83.0
	21-40%	2.7	1.3	0	0	10.2
	41-60%	0.1	0.1	0	0	0.1
	61-80%	0	0	0	5.4	0
Medium (35-200 years)	1-20%	8.1	33.5	9	296.9	184.9
	21-40%	3.8	4.5	1	71.2	40.5
	41-60%	0	0.2	0	9.2	1.5
	61-80%	0	0	0	0	0
High (<35 years)	1-20%	36.9	83.9	27	746.2	424.1
	21-40%	7.6	9.9	5	518.2	89.9
	41-60%	0.2	1.2	0	27.7	1.4
	61-80%	0	0	0	0	0

Any degree of tree mortality in a wildfire prone region is hazardous. Therefore, any infrastructures included in the bottom rows of this table—infrastructures exposed to canopy biomass loss where the wildfire rotation return interval is less than 35 years—are areas of concern for wildfire exposure. **Figure D 24** shows the location 44.7 miles of pipeline (bolded and italicized in the table above) this methodology has identified as exposed to canopy biomass loss and frequent wildfire return interval.

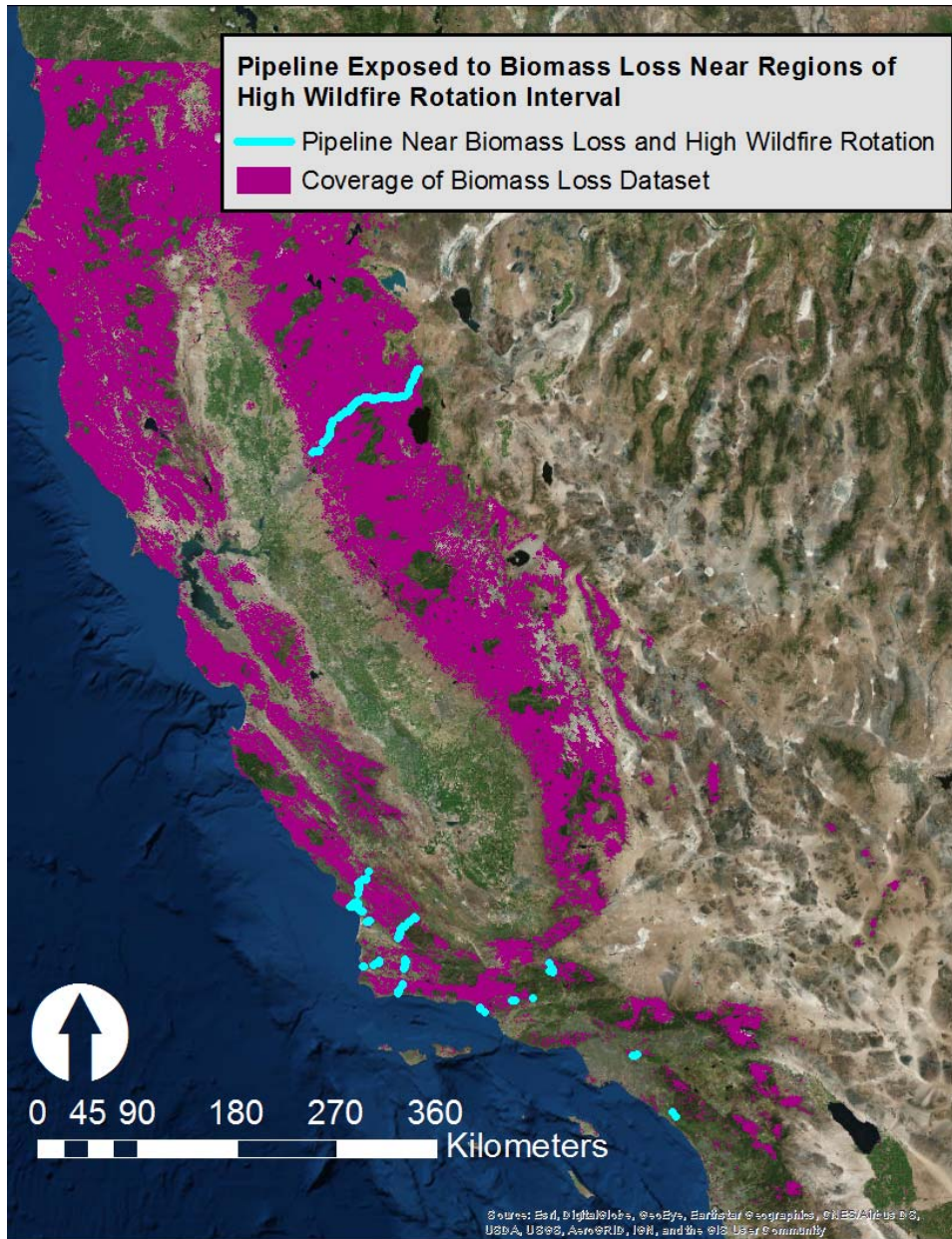

Figure D 24. The location of the 44.7 miles of pipeline exposed to biomass loss and a High wildfire rotation class. The pipelines in areas of concern are concentrated in the northern California Sierra Nevada and in southern California.

D.3 High Resolution Wildfire Behavior Modeling

During a wildfire, fire behaviors such as fire intensity, flame length, and rate of spread may seem unpredictable. However, these fire behavior attributes can be predicted using complex fire models built on assumptions about fuel composition and moisture levels, topography, weather, wind, and time of day. The wildfire behavior science community has advanced the fidelity of fire behavior modeling by calibrating their modeled simulations to observed fire behaviors. In this section, we detail our methodology for deriving landscape attributes at a 5m spatial

resolution from public data sources, for downscaling future weather conditions from Localized Constructed Analog (LOCA) data, for simulating wildfire scenarios under extreme wildfire conditions, for quantifying predictable hazards and mitigating hazards, and for calibrating our models to recent, catastrophic wildfires from this decade. An analysis of our results shows a 93% land cover classification accuracy and a strong correlation between modeled fire intensity and observed soil burn severity.

D.3.1 Introduction: High Resolution Wildfire Behavior Modeling

We conduct high spatial resolution wildfire behavior modeling to assess wildfire hazard near TFS assets. We do so by estimating potential wildfire behavior metrics under present and future climate conditions. The wildfire behavior simulation process involves topography model construction, surface classification into standardized fuel models, and a basic fire behavior (BFB) simulation using FlamMap software.

Given that modeling wildfire behavior at 30m resolution is a common practice, and we learn TFS stakeholders find it difficult to relate those model outputs to their asset exposure, we use high spatial resolution imagery and Light Detection and Ranging (LiDAR) to classify landscapes at 5m resolution. The model offers a more accurate and precise decomposition of fire behavior to identify wildfire behavior hazards. Digital Elevation Models (DEM), Digital Surface Models (DSM), and Canopy Height Models (CHM) are derived from first and last pulse LiDAR data. Land cover is classified as a selection of the thirteen Anderson fuel models for deriving wildfire behavior (Anderson, 1982). These models are incorporated into an object-based image analysis (OBIA) method, which constructs a classified landscape. This landscape is further used as an input layer into FlamMap, a wildfire behavior simulation software. Fire behavior simulation produces output metrics of flame length, fire intensity, and rate of spread. In order to model future conditions of wildfire, LOCA data are used to represent future extreme conditions of temperature and relative humidity, while vegetation and land cover properties are held constant through time (D. W. Pierce & Cayan, 2015; David W. Pierce, Cayan, & Thrasher, 2014). Mitigation procedures are simulated by modifying fuels to include the Scott and Burgan standard 40 fuel models to demonstrate the effect of mitigation on wildfire behavior (Scott & Burgan, 2005).

D.3.2 Model Inputs

D.3.2.1 Airborne LiDAR

Airborne LiDAR data are collected as discrete point clouds from USGS and OpenTopography, a National Science Foundation data facility developed by the San Diego Supercomputer Center. First and last return point data are processed using binning and interpolation algorithms available in ESRI ArcGIS 10.5 to construct DEM, DSM, and CHM for all study sites (See section D.3.3 – Elevation Models).

Since there is not full LiDAR coverage of California (**Figure D 25**), and multitemporal data is not available for any of the study sites processed, LiDAR is the limiting factor for modeling present conditions of elevation and surface object heights (**Table D 10**). To limit artifacts of land cover change between LiDAR and imagery collection, imagery is chosen based on temporal proximity to LiDAR collection instead of the most recent imagery available for the study site.

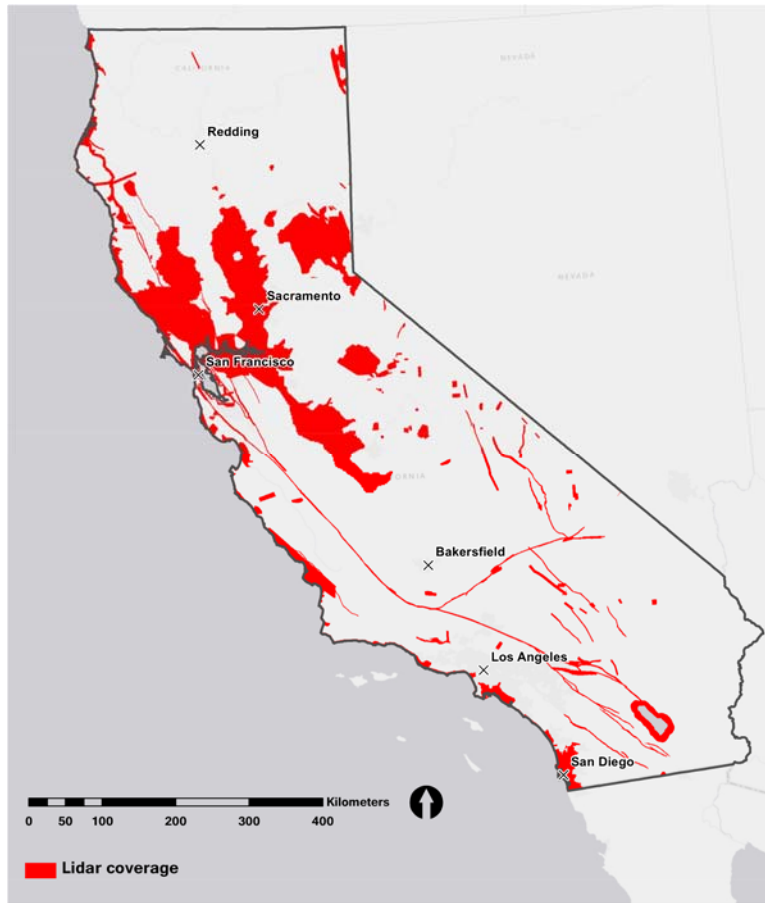

Figure D 25. Available Open Source LiDAR in California. (Data Source: United States Geological Survey, OpenTopography).

Table D 10. LiDAR datasets used for analysis

Bioregion	Dataset Source	Collection Date	Horiz. Point Spacing	Coordinate System
Sierra Nevada Mountains	OpenTopography	2014	4 inches	UTM Z10N
California Oak Woodlands	USGS	2007	3-6 inches	NAD83 State Plane CA ZIII
Southern California Mountains	OpenTopography	2005	1 meter	UTM Z11N

D.3.2.2 Imagery: National Agriculture Imagery Program (NAIP)

Multi-spectral orthoimagery from the National Agriculture Imagery Program (NAIP) is acquired from Google Earth Engine (GEE), an online platform that offers access to petabytes of public GIS data. Through GEE’s JavaScript-based API, the cloud-driven interface enables high-speed processing, visualization, and downloading. With the complete NAIP archive accessible and advantageous filter-by-date and filter-by-boundary image selection features, GEE allows

for the efficient download of NAIP images nearest to LiDAR collection dates, resulting in reduced data processing post-download. Once acquired, the NAIP data, which has a standard resolution of 1 meter, is resampled to 5 meters, since fuel models are representations of heterogeneous flammable land cover types, not individual objects, and classification of 1 meter pixels cannot be appropriately used to represent the heterogeneity assumed in the fuel models (M. Finney, personal communication, June 29, 2017). In addition to red, green, and blue wavelengths, NAIP imagery includes a near infrared band, the inclusion of which improves classification of land cover, making NAIP 4-band imagery a strong choice for the high-resolution wildfire behavior modeling. NAIP missions are flown every two to three years in California and 4 band imagery began in 2008 (**Table D 11**).

Table D 11. NAIP imagery datasets used for analysis

Location	Dataset Source	Collection Date	Coordinate System
Tahoe	USGS	2016	UTM Z10N
Contra Costa County	USGS	2009	UTM Z10N

D.3.3 Wildfire Behavior Simulation

D.3.3.1 FlamMap Basic Fire Behavior Analysis (BFB)

FlamMap is an open source software developed by the US Forest Service for simulating potential wildfire behavior with a GIS (Finney, 2006). Our research employs the Basic Fire Behavior (BFB) Analysis module of FlamMap. BFB applies pixel-based calculations of wildfire propagation to model static, spatially-explicit wildfire behavior characteristics (Albini, 1979; Rothermel, 1972). The pixel-based nature of the software allows for quicker processing than an equivalent vector-based software, such as FARSITE, making it an ideal choice for conducting analyses of large areas and high spatial resolution data. We select BFB analysis for the scope of our project because, as opposed to spread models alternatives, BFB does not require an ignition point. While a stochastic model could be developed to predict a potential source of ignition, TFS stakeholders should operate and mitigate under the assumption that wildfire could ignite near any of their assets that neighbor vegetation. FlamMap BFB inputs include spatially explicit landscape data, as well as initial fuel moisture data and temporally explicit climate data (**Table D 12**).

Table D 12. Inputs to Basic Fire Behavior Simulation.

	<i>Input Data</i>	<i>Source</i>	<i>Units</i>
Spatially Explicit	Fuel Model	Imagery, CHM	Standard Fuel Classes (Integer)
	Elevation	DEM	Meters
	Slope	DEM	Percent
	Aspect	DEM	Degrees
	Canopy Cover	CHM	Percent
	Stand Height	CHM	Meters
	Canopy Base Height	Constant	Meters
	Canopy Bulk Density	Constant	kg/m ³
Non-spatially explicit	Fuel Moisture	US Forest Service	1-hr, 10-hr, 100-hr
	Temperature	observed or LOCA	Fahrenheit
	Relative Humidity	observed or LOCA	Percent
	Precipitation	observed or LOCA	Inches
	Wind Direction	Constant	Degrees
	Wind Speed	Constant	mi/hr
	Cloud Cover	observed or 0	Percent

D.3.3.2 Wildfire Behavior Hazard Metrics: Spread Rate, Flame Length, Fire Intensity

Spatially explicit and non-spatial inputs to the BFB produced estimates of fire intensity, flame length, and rate of spread as outputs. Fire intensity, measured in BTU/ft, is a measure of heat emitted per unit area. Flame length is the length of the flame emitted measured in feet, and is determined by both the rate of spread and heat emitted per unit area (Andrews & Rothermel, 1982). Rate of spread, measured in feet per minute, is the rate at which an object ignites and indicates the threat of an object to propagate wildfire. Fire intensity, measured in BTU/ft, is a measure of heat emitted per unit area (**Table D 13**).

$$\begin{array}{cccc}
 \text{Fire intensity} & = & \text{Heat of combustion} & \times & \text{Fuel consumed} & \times & \text{Rate of spread} \\
 (\text{Btu/sec.-ft.}) & & (\text{Btu/lb.}) & & (\text{lbs./ft.}^2) & & (\text{ft./sec.})
 \end{array}$$

Fire Suppression Tactics and Wildfire Behavior Hazard Metrics

These wildfire behavior hazard metrics are used to inform suppression capability of a wildfire eliciting these characteristics. **Figure D 26** is a Fire Characteristics Chart, also known as a “Hauling Chart,” and is a useful decision making tool for hauling in hand crews, equipment, aircraft; or hauling everything out of there (Andrews, 2010).

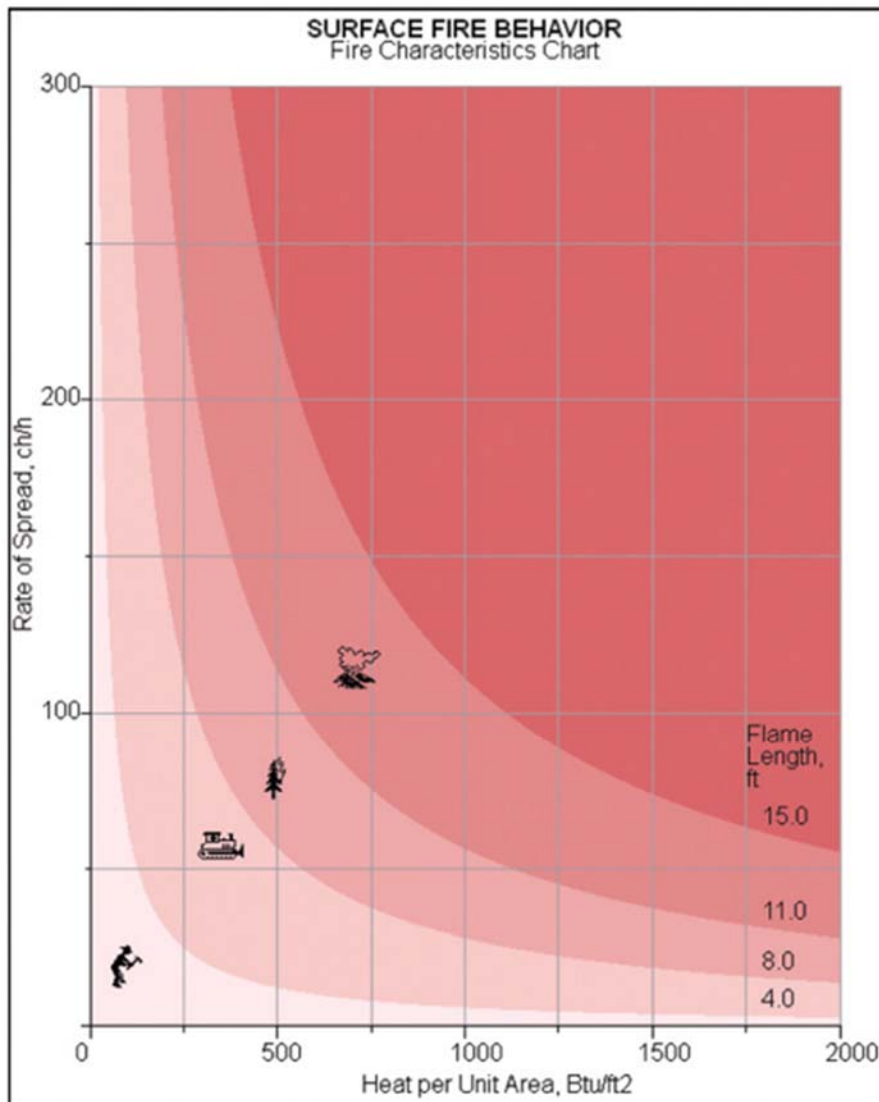





Figure D 26. Wildfire Behavior Metrics and Fire Suppression Tactics (Andrews & Rothermel, 1982)

Table D 13. Description of selected fuel metrics as pertaining to potential methods of suppression.

<i>Rate of Spread (ft/min)</i>	<i>Flame Length (ft)</i>	<i>Fire Intensity (BTU/ft)</i>	<i>Figure 3.3.1.</i>	<i>Interpretation</i>
<5	<4	<100		Fire can be maintained by hand tool resources.
5-20	4-8	100-500		Handline may not hold fire, bulldozers and air support may be utilized.
21-50	8-11	500-1,000		Fires are difficult to control, efforts may be ineffective, and resources shifted to preventing spread, as opposed to attacking the fireline.
>50	>11	>1,000		Risk of major fire runs. Control efforts are ineffective.

(Source: Andrews & Rothermel, 1982)

D.3.4 Elevation Surfaces

Elevation surfaces are constructed in an automated process using airborne Light Detection and Ranging (LiDAR) data. LiDAR measurements are used to construct Digital Elevation Models (DEMs) and Digital Surface Models (DSM). The difference between the DSM and DEM is used to create a Canopy Height Model (CHM) and Canopy Cover models. The models are used to determine slope, aspect, stand height, and canopy cover values that BFB simulations required.

D.3.4.1 Source Data

Airborne LiDAR are acquired as discrete point clouds. Average point spacing, or average horizontal resolution, of LiDAR data ranges from three inches to one foot, and varies between datasets. Point clouds either contained first and last return observations, or all observed returns. Point cloud binning operations used to construct elevation and surface models use minimum and maximum values within raster cells. For a ground surface that is observed by airborne LiDAR with all return data, the first pulse, last pulse, and all intermediate returns would be the same. For a non-ground surface, such as vegetation or a built object, the first return will correspond with the maximum height return value and the last return will correspond with the minimum height return value. Therefore, for the purposes of constructing DEMs and DSMs, first and last pulse data are functionally equivalent to all return data. All Airborne LiDAR source data are received as .las files. Projection and datum of source data varies, and all data is ultimately processed in Universal Transverse Mercator projection.

D.3.4.2 Elevation Models

DEMs are derived from point clouds to construct raster elevation models for input into FlamMap Basic Fire Behavior simulation. Point cloud data is originally in .las file format and is converted to an ArcGIS LAS Dataset format. For source data with .las files that are parsed by

first and last return, two separate LAS Datasets are constructed. For source data acquired as a point cloud of all returns, an aggregate LAS Dataset is created.

To construct the raster DEM from point clouds, the LAS Datasets are input into a binning algorithm, in which the minimum return value within each raster cell is assumed to be ground surface. Cell size for binning is set to align with imagery resampled to five meters. For first and last return datasets, only last return data is used to construct the elevation model. For datasets including all returns, the minimum of all points in the five-meter cell is assumed to be the ground surface. Cells with no return data are populated by rendering a triangulated surface across the empty space and using a linear interpolation to ascribe elevation values to a contiguous raster.

D.3.4.3 Canopy Height Model

A raster Digital Surface Model (DSM) is constructed as an intermediate step before calculating a Canopy Height Model (CHM). Similar to DEM construction, to construct the DSM, a binning algorithm using five-meter cells is used to aggregate LiDAR points. The maximum height within each raster cell is calculated as the surface. Similar to the DEM, the DSM represents the maximum of all points used for all-return datasets, and the maximum of first return points are used for parsed datasets. Instead of an interpolation algorithm to fill voids, raster cells with no return points are given the value of the DEM raster.

The vertical difference between the DEM and DSM is calculated as the CHM ($DSM - DEM = CHM$). This calculation alone yields raster cells that indicate error, usually due to bird presence during LiDAR collection, so an algorithm is developed to eliminate the outlying points. If any raster cells are greater than 300 feet then they are removed from the contiguous CHM surface. The algorithm filled the void with a natural neighbor interpolation to recreate a contiguous CHM.

D.3.4.4 Elevation and Surface Models: Sources of Error

Sources of error in this process are those that are typically artifacts of deriving terrain models from LiDAR data. The observed point returns collected during flight are unlikely to be the true minimum and maximum of the true surface. To increase likelihood of nearly true minimum and nearly true maximum representations, ESRI recommends a minimum of four points for each raster cell created in the binning algorithm; based on a range of four-inch to one-foot horizontal resolution of LiDAR, five-meter cells contained approximately 256 to 2400 returns to bin the minimum and maximum elevation, but can still contain significantly fewer depending on point density for a cell. Another source of error is the estimated elevations derived from the triangulated network and linear interpolation algorithm. However, occurrences of voids are rare due to large binning cells relative to the fine horizontal resolution of the LiDAR flights.

D.3.5 Classification of Fuels

D.3.5.1 Fire Behavior Fuel Models

Fire behavior fuel models (FBFM) are used to represent the components of surface fuels that produce predictable surface fire spread behavior. Previous research on fuel compositions and fire behavior characteristics has expanded Anderson's original set of 13 FBFM to a current standard of 40 FBFM (Scott & Burgan, 2005). FBFMs are mathematical representations of a vegetation type's fuel loading, particle size class, surface area to volume ratio, heat content, fuel

bed depth, and dead fuel moisture of extinction. The Scott and Burgan 40 (S&B 40) FBFMs offer the ability to model fuels with live herbaceous components and a range of fuel loading options for each vegetation class. This makes the S&B 40 FBFM particularly useful for modeling prescribed fires when relative humidity, wind and weather conditions do not present serious fire dangers. The Anderson 13 FBFM, on the other hand, represent fully cured fuels since they do not account for live herbaceous moistures. A fully cured fuel is one that is completely dead and only needs ignition to express the most extreme fire behavior characteristics for that fuel. As such, the Anderson 13 FBFM are useful when modeling fire spread behavior during the severe driest period of the fire season (Anderson, 1982). In this study, all fire-carrying fuels are classified into the Anderson 13 FBFM in order to characterize the maximum, static fire behavior potential for a landscape.

The potential fire behavior of FBFMs are products of Richard Rothermel's surface fire spread equations, which do not model the physics of combustion, but closely approximate the behavior of observed fire spread behavior (Rothermel, 1972). FBFMs are not representative of perfectly homogenous fuel compositions. Instead, these models are calibrated over an unspecified area with the assumption of heterogeneous compositions of fuels in order to mimic the spatial heterogeneity and species composition of wildland fires. Classifying a fuel into an FBFM is a time-intensive task that typically requires field observations and a knowledge of the ecoregion's vegetation in order to fit the FBFM to the observed fuel and achieve the appropriate predicted fire spread behavior (Ager, Finney, Kerns, & Maffei, 2007). This study substitutes on-the-ground sampling for remotely sensed data in order to classify landscape objects into FBFMs. This method has inherent accuracy limitations: airborne LiDAR data does capture the vertical structure of fuel complexes well, and processing remotely sensed data succeeds in its ability to rapidly approximate fuel models for land cover at the landscape-scale. To achieve a more precise characterization of a landscape's maximum, static fire behavior potential, it is recommended to consult expert fuel managers and ecologists to improve upon the methods presented herein.

Remotely sensed data from the Landsat series has become a critical medium for fuel managers to classify land cover into the FBFM. The Landsat series has a 30m spatial resolution, captures imagery for all fire environments across the US, and is easy to classify into land cover because of its many spectral bands. However, 30m spatial resolution is too coarse to sufficiently understand the fire behavior of surface fuels for a local scale assessment when the minimum pixel has an area of 900 sq.m. This study demonstrates the benefits of classifying fuels at 5m using resampled NAIP imagery, where the minimum object size is 25 sq.m. Due to the approximations of surface fire behavior made by Rothermel's equations and the inherent heterogeneity of each FBFM, 5m spatial resolution represents the upper resolution limit before the physics of combustion are apparent and the quality of Rothermel's spread equations begin to break down. Therefore 5-m (16.4-ft) spatial resolution is utilized in order to improve the resolution of land cover and of a landscape's maximum, static fire behavior potential. **Figure D 27** and **Figure D 28** are images of the fuel types used to standardize each FBFM taken from Anderson's "Aids to determining fuel models for estimating fire behavior" (1982).

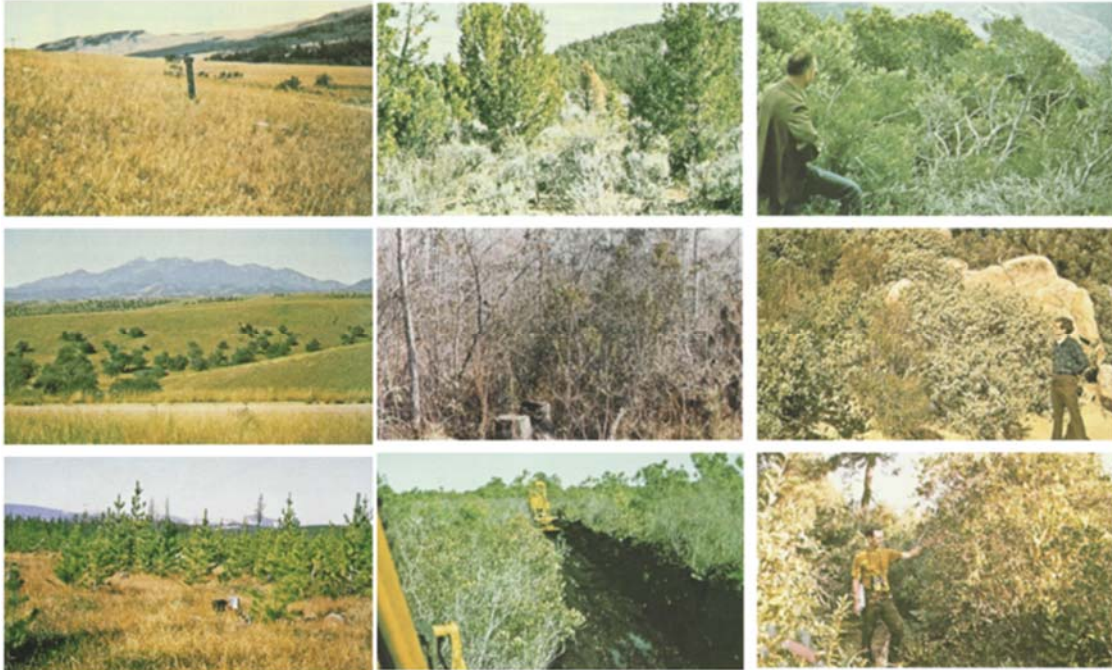

Figure D 27. Grass fuel type: “Short Grass” (FBFM 01) (left); Shrub fuel types: “Dormant Brush/Hardwood Slash” (FBFM 06) (middle), “Chaparral” (FBFM 04) (right). (Source: Anderson, 1982).

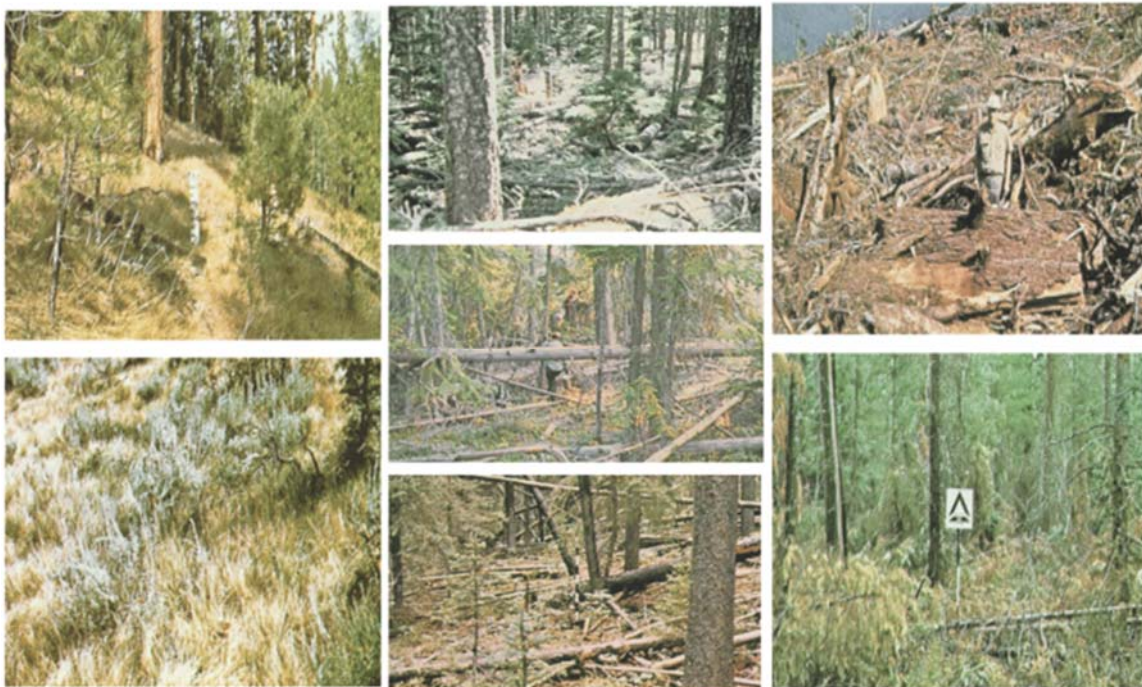

Figure D 28. Tree fuel types: “Timber Grass and Understory” (FBFM 02) (left), “Timber Litter and Understory” (FBFM 10) (middle), “Heavy Logging Slash”(FBFM 13)(right). (Source: Anderson, 1982).

Land cover is first classified into burnable and non-burnable land cover, then classified by height into land cover that fits the Anderson 13 FBFM. There 3 main FBFM groups used in this study include: Grass, Shrub, Tree, and Non-burnable. From this set, land cover is rapidly classified into FBFMs based on our assessment of primary vegetation types for each ecoregion studied. The classifications and assigned FBFM represent the expected fuel complexes, but do not account for variation in fuel ladders, so fuel strata are standardized by the FBFM.

We use one FBFM for all grass-type fuels: FBFM 01. The “Short Grass” (FBFM 01) fire behavior fuel model is calibrated to the fire behavior observed from annual and perennial grasses under 2 feet tall. In fire ecology, grasses are known as 1-hour fuels, which describes how a grass’s moisture content takes approximately 1 hour to reach equilibrium with the local relative humidity. Grasses represent light, flashy fuels that burn at relatively low intensities and flame lengths, but high rates of spread. All of California’s fire environments utilize grasses as the primary vector for surface fire spread.

We used two FBFMs for all shrub-type fuels: FBFM 06 and FBFM 04. The “Dormant Brush” (FBFM 06) fire behavior fuel model is calibrated to the fire behavior for a wide range of chaparral-type shrubs under 6 ft tall. Shrubs are mostly considered 10-hr fuels and typically have fire behaviors with high intensities, high flame lengths and moderate rates of spread. The “Chaparral” (FBFM 04) fire behavior fuel model is similar to FBFM 06, but has a fuel bed depth above 6 feet.

We use three FBFMs for all tree-type fuels: FBFM 10, FBFM 02, FBFM 13. The “Timber Litter and Understory” (FBFM 10) fire behavior fuel model is calibrated to the fire behavior observed for a patch of forest with an intermix of fine fuels and branches. While this fuel model may be considered for any forest type where “heavy down material is present” (Anderson, 1982), we apply this fuel model to trees in the forest-dominated ecoregions like the Sierra Nevada Mountains. The “Timber Grass and Understory” (FBFM 02) fire behavior fuel model is used in grass- or shrub-dominated ecoregions, like California Oak woodlands and Southern California Mountains. Surface fires spreading through these fuels generate high intensities and pass primarily through fine herbaceous fuels. The “Heavy Logging Slash” (FBFM 13) fire behavior fuel model is used. When surface fires spread through this fuel type, fire behaviors do not weaken only if it reaches a fuel break or a change in fuel type. This FBFM is applied to all senescent trees as a proxy for modeling the behavior of dead trees.

When modeling potential fuel treatments, hazardous fuel loads are reclassified using the S&B 40 FBFM in order to optimize mitigation. While these FBFM are capable of dynamically adjusting fuel moisture, in order to compare directly to a fuel model constructed with the Anderson 13 FBFM, treated vegetation is assumed to be fully cured and fuel moisture assigned accordingly (Scott & Burgan, 2005). In order to choose the appropriate fuel model to represent mitigation, we consult the local USFS fuels manager for the region about mitigation modeling.

“Low Load Activity Fuel” (SB1) replaces fuels formerly classified as shrubs “Dormant Brush” (FM06). This model is chosen at the recommendation of a Fuels Manager from the Truckee Ranger District, which is located near the Sierra Foothill region containing the TFS infrastructure (L. Ferguson, personal communication, October 3, 2017). Low Load Activity Fuel is representative of mastication fuel treatment, a process used to grind standing fuels into compact surface fuels with moderate ignition spread rates and low intensity flames (McDaniel, 2013).

“Low Load Compact Conifer Litter” (TL1) replaces “Timber Litter and Understory” (FM10) to represent thinning of tree understory. This model is chosen to represent treated tree understory in the Northern Sierra ecoregion (L. Ferguson, personal communication, October 3, 2017). The treatment, and representative fuel model, yield a fuel bed with a low spread rate and flame length.

D.3.5.2 Object-Based Image Analysis

Developing a high-resolution model of the fuels on a complex landscape requires objects, not pixels, to be the minimum mapping unit for analysis. In other remote sensing applications, an Object-Based Image Analysis (OBIA) has proven to be an effective means for classifying features by their spectral and spatial attributes (Blaschke et al. 2001). Traditional wildland fuel mapping uses 30m spatial resolution to segment and classify fuel patches (Chuvieco et al. 1989). However, for a local-scale fire behavior assessment, having nominal pixel sizes of 30m is insufficient for capturing the spatial heterogeneity of fuels needed for a local-scale, landscape assessment. When using 30m spatial resolution, many areas are generalized into the same fuel type despite having a complex spatial heterogeneity of fuels. This overgeneralization of landscapes at the local scale presents a problem for fuel managers and fire suppression managers who use fire behavior modeling to justify and support their management decisions. With 5m spatial resolution, the minimum area for objects is 25 m² and captures all of the minimum attributes needed to maintain the fidelity of fire behavior fuel models (see Section D.3.5 - Classification of Fuels). However, this strategy clearly requires more time to choose fuel type models for all 5 m² pixels. However, we do not apply this globally, but just in areas with high value TFS assets. At this high spatial resolution, the accuracy of land cover classification significantly improves where landscapes have heterogeneous land covers since the complexity of features and their edges are more easily discernible. As such, landscapes classified into objects at 5m (16.4 ft) spatial resolution provide insight into the potential fire behavior observed at local scales where vegetation patterns, types, and topography are increasing nuanced and complex.

Image Segmentation

Segmenting high spatial resolution imagery into discrete objects is critical to the understanding of local hazards around TFS infrastructure. Objects are segmented using the Segment Mean Shift (SMS) algorithm within ArcGIS. SMS utilizes a region-growing kernel that forms boundary segments between pixels with high contrasting values. This algorithm succeeds at creating boundaries between dissimilar fuel types because it can create complex object structures regardless of scale and can be applied to multi-band datasets like Landsat or NAIP imagery.

Objects are created based on the selected fuel classes from the Anderson 13 FBFM. Segmentation into these objects is a three-stage process. First, the height raster is segmented into ground and non-ground surfaces. Second, the NDWI raster for each surface is extracted and segmented using SMS. The objects created from these surfaces are merged into a continuous surface that is then classified as burnable or non-burnable. Third, the heights raster is segmented by the burnable surface and further segmented into grass, shrub, and tree surfaces based on their Anderson 13 FBFM specified heights. Fourth, NAIP imagery is segmented for each fuel class using SMS to create internal segments appropriate for each fuel class. After object boundaries are created for each whole object feature, these datasets are spatially merged into a

contiguous surface. Having spatial contiguity between objects is important when modeling wildfire because fuels are represented as a matrix of values.

In the first stage of segmentation, the heights raster is segmented into ground and non-ground surfaces. The ground surface is any height at or under 0.6096 m and the non-ground surface is any height above 0.6096 m. NDWI is selected as the raster to segment into burnable and non-burnable fuels because it highlights impervious and water surfaces and is useful at delineating those surfaces from vegetation surfaces. Then, these objects are classified into burnable and non-burnable fuels according to their median spectral enhancement values (see the following section).

Once the objects from these surfaces are fully classified into burnable and non-burnable fuel objects, these objects are merged and their boundaries are created. The burnable fuels boundary is used to extract the heights surface contained within it. This burnable fuels heights raster is segmented into grass, shrub, and tree heights by height thresholds specified by the Anderson 13 FBFM: short grass has a height range of 0 to 2 feet, dormant shrubs have a height of 2 to 10 feet, and trees are above 10 feet. These height thresholds are assumptions about the vertical fuel structure that cannot be directly observed from LiDAR or NAIP imagery. Therefore, these heights thresholds are a limitation of the data and may lead to an incorrect classification of a shrub or tree, where the height of a young sapling lodgepole pine, for example, may be confused as a tall shrub. Once the heights are created for each fuel class, boundaries for the grass, shrub, and tree objects are created and used to extract the NAIP imagery contained within each.

SMS is used to segment the Red, Green, Blue and Near-Infrared bands from NAIP imagery for each fuel class in order to optimize internal segmentation and capture each ground object's horizontal boundaries. The spectral and spatial detail parameters passed into the SMS algorithm are used to optimize the segmentation of each fuel class. Lower spectral and spatial detail values do not produce a high number of internal segments because it smooths the spectral and spatial information before creating segments. A lower spectral and spatial detail is selected for grass because grass does not need a high internal segmentation since grass is considered a continuous fuel, unlike shrubs and trees. High spectral and spatial parameters are used to segment individual fuel class members for the shrub and tree surfaces. Generalizing these parameters for a fuel class may lead to instances of over- and under-segmented objects, such that one tree may be segmented horizontally into two objects, or two horizontally overlapping shrubs may be classified as one shrub. Perfect segmentation of objects is difficult at the spatial resolution used because one object may appear to have two boundaries when looking at it from above or boundaries between objects may be blurry.

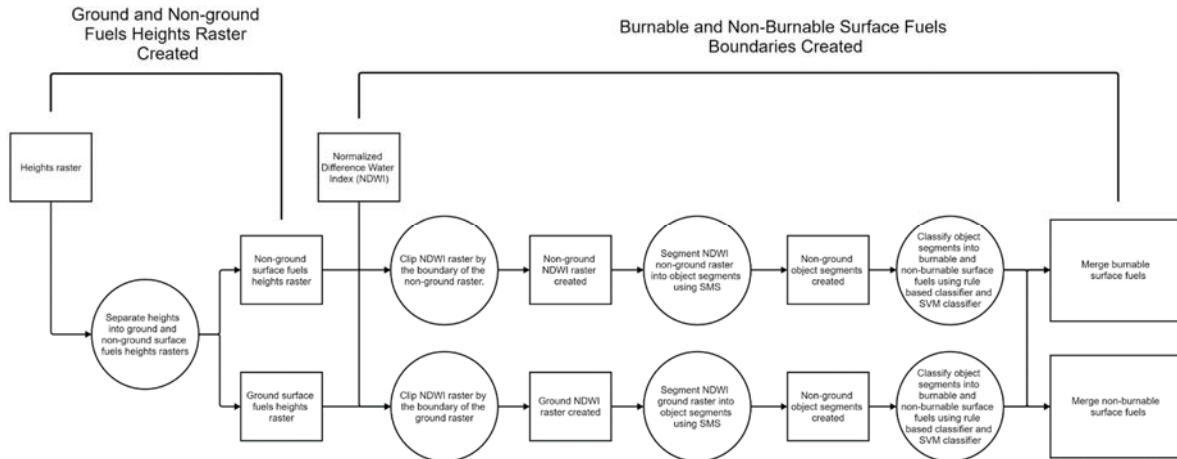
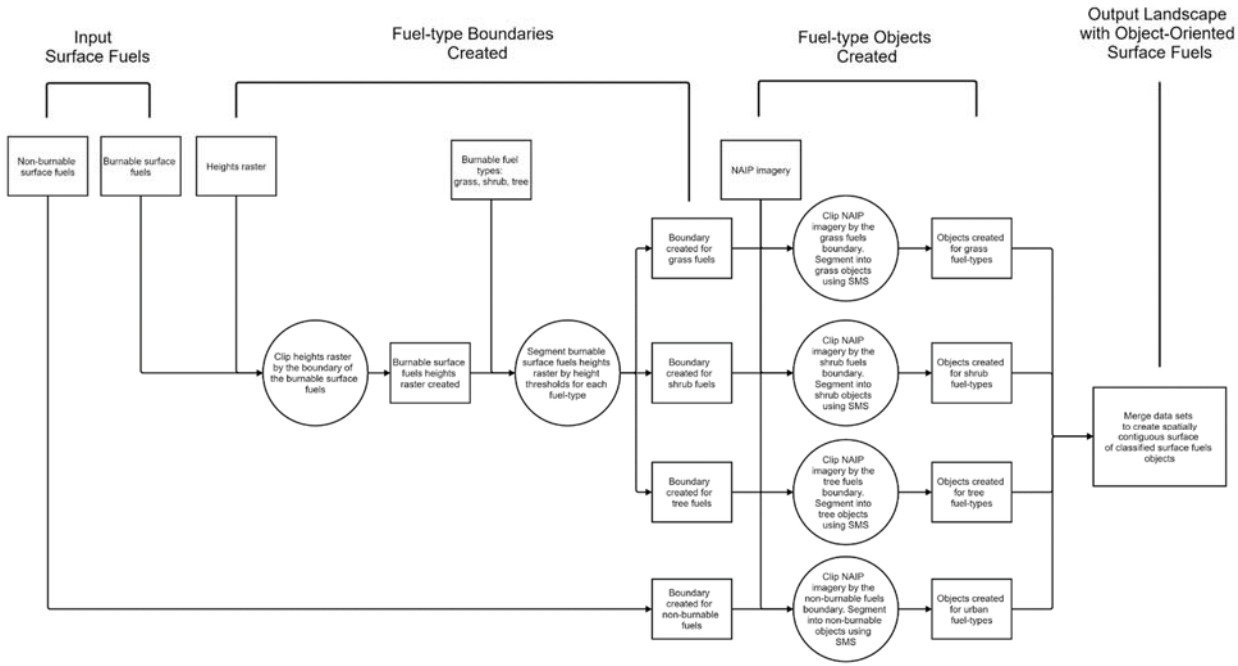

Figure D 29. The process used for creating burnable and non-burnable surface fuels. This process involves creating non-ground and ground height rasters, clipping a Normalized Difference Water Index raster by the boundaries of these height rasters, segmenting this new raster using the Segment Mean Shift (SMS) algorithm, classifying these object segments using a rule-based classifier and Support Vector Machines (SVMs) classifier, and then merging the resulting objects into their respective burnable and



non-burnable surfaces.

Figure D 30. The process for creating a spatially contiguous landscape with object-oriented surface fuels: This process involves clipping the heights raster by the boundaries of the burnable and non-burnable surface fuels, segmenting this new burnable heights raster by the height thresholds for each burnable fuel type, clipping NAIP imagery by each of these new burnable fuels surfaces, segmenting this clipped NAIP imagery using SMS algorithm, and merging these objects into a single data set.

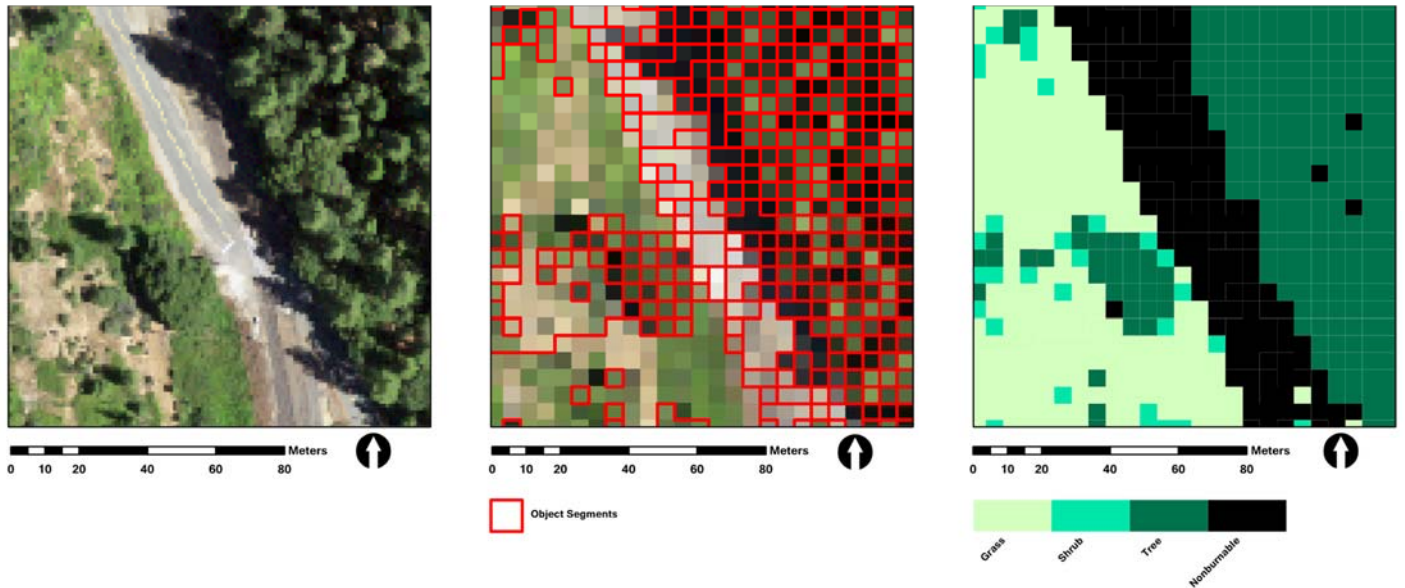

Figure D 31. The Segment Mean Shift (SMS) algorithm was used to create the object boundaries for grass, shrub, tree, and urban surface fuels.

Spectral Indices

To access each object’s unique spectral signatures for classification, the Red (R), Green (G), Blue (B), and Near-Infrared (NIR) bands from the NAIP imagery are used to create spectral indices (**Table D 14**). Spectral indices enhance the information of remotely sensed data and are useful to indicate characteristics such as vegetation health and soil moisture content. To confidently separate land cover into burnable and non-burnable fuel types, we use the Normalized Difference Vegetation Index (NDVI), Green Normalized Difference Vegetation Index (GNDVI), Normalized Difference Water Index (NDWI), and Optimized-Soil Adjusted Vegetation Index (OSAVI). NDVI is created because it distinguishes varying densities of green vegetation from other land cover and is useful for monitoring vegetation health. Similarly, GNDVI is created to discriminate between green and brown vegetation since it is more sensitive to chlorophyll concentrations than NDVI. NDWI is created to delineate impervious surfaces from vegetated surfaces and is found to be very effective for highlighting water bodies and pavement. OSAVI is used to highlight instances of sparse vegetation where soil is visible through canopies or surrounded by barren soil. These indices are initially calculated through Google Earth Engine at 1-meter resolution for the entire State. With its incredible processing power and iterative flexibility, GEE allows for quick prototyping. However, because the platform is not built for handling LiDAR input data or separate software uploads (like FlamMap), our research team decided to carry out the automation of our stakeholder-specific analyses locally. Therefore, the index data used in the final study is ultimately calculated post-download.

Separation between fuel types is achieved by finding threshold ranges to use for burnable and non-burnable land cover masks. Narrow data number ranges for each spectral index are

recorded for each of the modeled bioregions in order to account for varying spectral characteristics from vegetation from different bioregions. These threshold ranges are utilized in the rule-based classification process that evaluates an object's unique spectral index attributes and assigns the object to a corresponding class.

Table D 14. Spectral index threshold values used in to classify surfaces into burnable and non-burnable surface fuels.

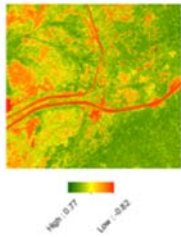
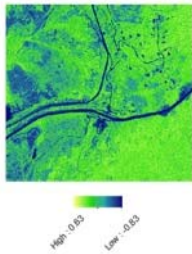
Spectral Index	Fuel Type	Threshold values used for classification		
		Forest-dominated ecosystems	Grass-dominated ecosystems	Shrub-dominated ecosystems
<p>Normalized Difference Vegetation Index (NDVI)</p> $\frac{\text{NIR} - \text{R}}{\text{NIR} + \text{R}}$ 	Burnable	[-0.01, 0.60]	[-0.18, 0.50]	[0.02, 1.00]
	Non-burnable	[-0.88, -0.12]	[-0.88, -0.20]	[-1.00, -0.05]
<p>Green Normalized Difference Vegetation Index (GNDVI)</p> $\frac{\text{NIR} - \text{G}}{\text{NIR} + \text{G}}$ 	Burnable	[-0.02, 0.38]	[-0.30, 0.38]	[0.00, 1.00]
	Non-burnable	[-0.94, -0.05]	[-0.94, -0.17]	[-1.00, -0.05]

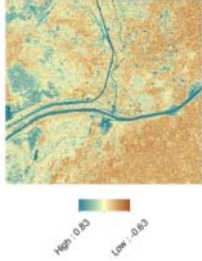
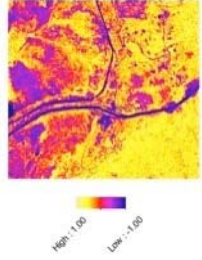
<p>Normalized Difference Water Index (NDWI)</p> $\frac{G - NIR}{G + NIR}$ 	Burnable	[-0.46, -0.03]	[-0.41, 0.18]	[-1.00, -0.1]
	Non-burnable	[-0.02, 0.91]	[0.24, 0.91]	[0.02, 1.00]
<p>Optimized Soil-Adjusted Vegetation Index (OSAVI)</p> $\frac{NIR - R}{NIR + R + 0.16}$ 	Burnable	[-0.08, 0.76]	[-0.15, 0.76]	[0.20, 1.00]
	Non-burnable	[-0.94, -0.13]	[-0.94, -0.25]	[-1.00, -0.4]

Data Fusion

The primary objective for data fusion in our methodology is to populate each object with attribute information useful for its classification into a fire behavior fuel model. The zonal median for each spectral index and the zonal maximum height are calculated for each object. The median value for each spectral index is generated in order to reduce bias from outliers that may arise from the spatial resolution or from spectrally mixed pixels. The maximum height value for each object is generated because maximum height is useful for categorizing land cover types.

One limitation of the datasets used for the data fusion is differing data collection dates. The date of the NAIP imagery used is selected based on its closest time period to the LiDAR collection date because NAIP imagery is flown every two to three years, and typically there is one LiDAR dataset for an area. Therefore, fusing spectral values and LiDAR data from non-overlapping periods introduces an error because an object that is present in the LiDAR may not be present in the NAIP imagery, or vice-versa. An example of such an error may include creating an object boundary for a tree from 2012 imagery and fusing it with a LiDAR dataset from 2013 after the tree was cut down. These instances are artifacts of the data fusion process. There are several possible errors that may arise in the classification of the objects due to changes in the landscape that happened between the data collection dates. Therefore, the datasets used are not totally ideal for data fusion, instead imagery and LiDAR should be collected at the same instance whenever feasible. Yet, the information derived from fused lidar and multispectral data is rich and so we use it in our research even with these caveats. These potential artifacts that arise from this study are an example of how LiDAR should be flown more frequently to reduce the collection date discrepancies between the imagery and LiDAR.

Classification

Objects have a range of spectral information that, when associated with spatial information, can yield specific characteristics useful for classification (Blaschke, 2010). Object heights are equally useful. The 4 fuel classes used as label classes for this study were selected from the Anderson 13 FBFM.

Once objects are classified into burnable or non-burnable surfaces, each object is evaluated based on its maximum height (**Figure D 32**). Burnable objects are further classified into grass, shrubs, and trees. Objects that could not be classified from this process are labeled as “Undetermined” objects and are collected into a dataset. Object that are classified into land cover classes are used as a data to train the SVMs algorithm in order to classify the “Undetermined” objects.

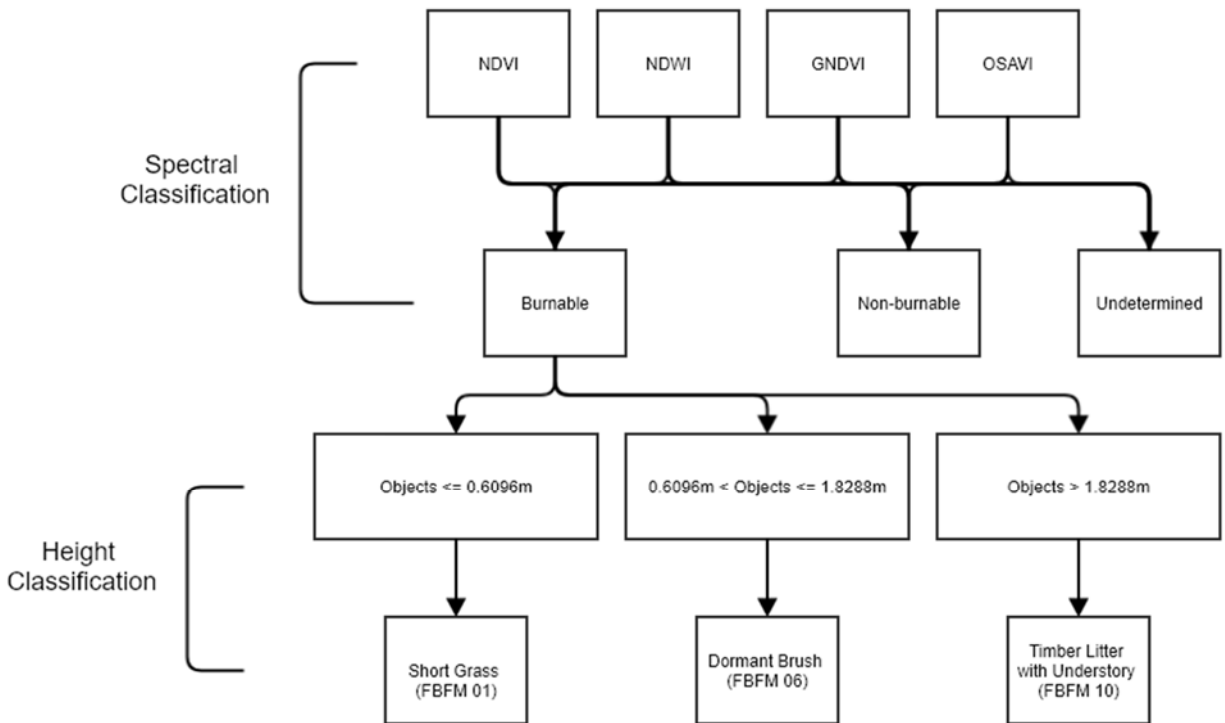

Figure D 32. Flowchart of rule-based classifier.

Support Vector Machine in Land Cover Classification

The Support Vector Machines (SVMs) algorithm within ArcGIS is utilized to classify objects that remained unlabeled after the rule-based classifier. These objects are given an “Undetermined” designation. Many of the “Undetermined” objects are rock and perennial grasses.

The SVMs algorithm is a machine learning approach to classification that creates nonlinear segmentation between training samples in a hyperplane. SVMs have often been found to provide higher classification accuracies than other widely used pattern recognition techniques and appear to be especially advantageous in the presence of heterogeneous classes (Melgani et al., 2004).

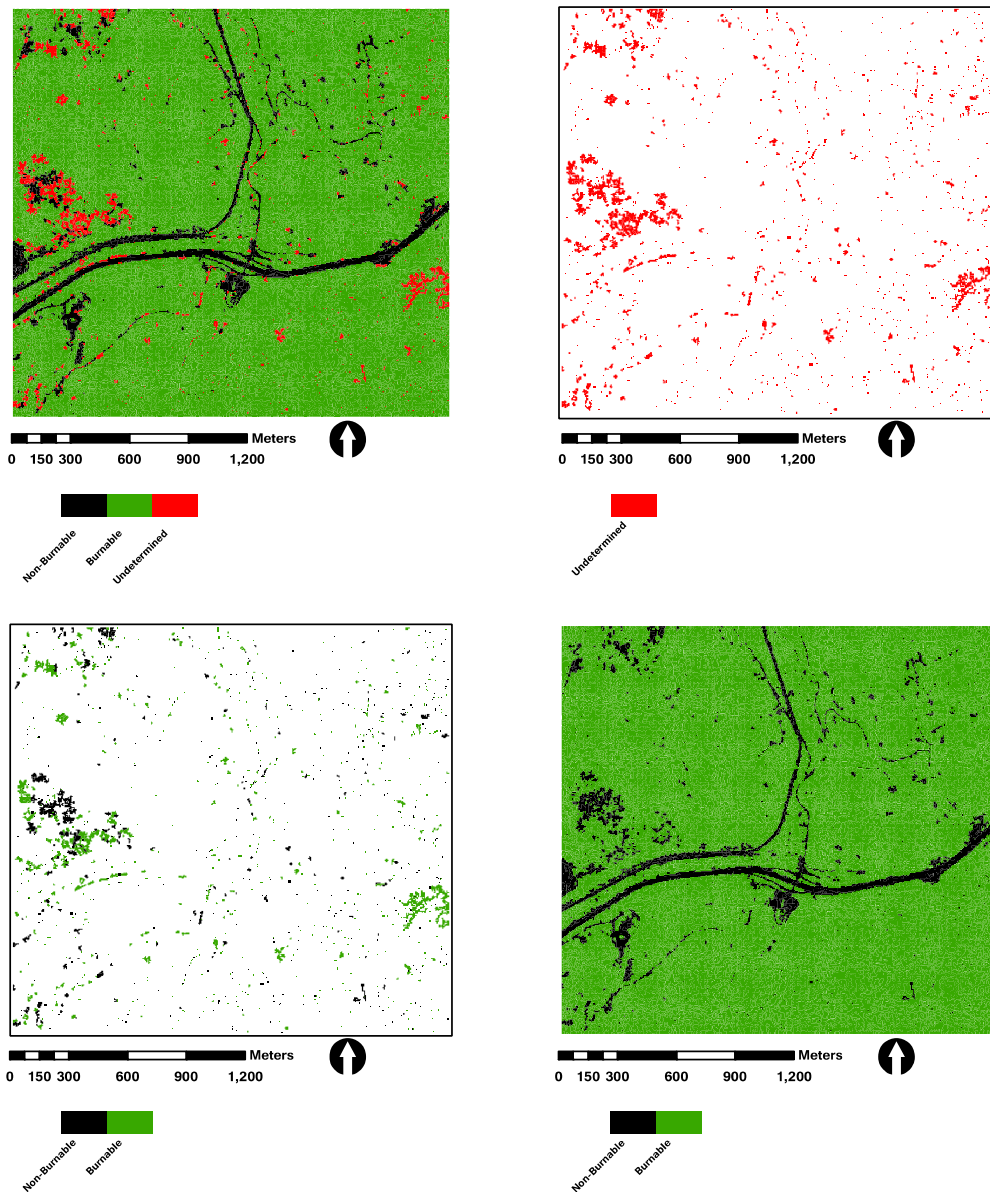

Figure D 33. Land cover classified by rule-based classifier (top left), objects that are undetermined (top right), objects classified using Support Vector Machines (bottom left), contiguous objects classified (bottom right).

From the dataset of objects generated from the rule-based classification, burnable and non-burnable objects are used as training samples to train a SVM classifier rule. This classifier rule is applied to a LiDAR-Multispectral stack comprised of NDVI, NDWI and heights. The SVM algorithm within ArcGIS produces a classified raster data output with unique identifiers for each fuel class. Using a similar method as the rule-based classifier, these unique identifiers are assigned to the objects according to the most frequently occurring label within each object's

zone. This final output layer is a vector data file with the contiguous study site classified into burnable and non-burnable fuel classes (**Figure D 33**).

D.3.6 Ancillary FlamMap Inputs

D.3.6.1 FlamMap

FlamMap Basic Fire Behavior (BFB) simulations use ancillary data, both spatial and non-spatial, to supplement spatial fuel model classifications of a surface. Spatial ancillary data included topography data to represent the fuel model surface and canopy data that correspond with fuel models representing tree cover. Static wind data, and temporally varying climate data are used to condition fuel moistures to simulate extreme conditions. Temporal climate data are used to represent potential changes in future wildfire behavior in conjunction with the representation of current land cover.

Topography Data

Topography data are derived from last pulse LiDAR data that are processed into a rasterized DEM (see Section D.3.4). Landscape topography data readable by BFB simulations include elevation, slope, and aspect. Elevation data are ASCII GRID representations of DEMs. Elevation is used in BFB simulation for adiabatic adjustment of temperature and humidity climate variables. Slope data are calculated using a three-by-three moving window along the raster and a planar method to calculate the slope of each DEM cell based on the relative elevation of the surround eight cells. A similar moving kernel planar analysis method is used to calculate aspect (ESRI Corp.). FlamMap uses slope and aspect to calculate the slope effects on fire spread, and the fuel conditioning effect of solar radiance (Finney, 2006).

Canopy Data

Spatial canopy data, including stand height and canopy cover are input into BFB analyses as ASCII GRID. Stand height and canopy cover are estimated using LiDAR data, and have proved to bolster accuracy of intensity and spread metrics produced by wildfire behavior simulations (Andersen, McGaughey, & Reutebuch, 2005). Stand heights are ASCII representations of CHMs, which are calculated as the difference between the DSMs and DEMs (see Section D.3.4). Vertical canopy covers (VCC) are calculated as the ratio of non-ground LiDAR returns to all returns within a raster cell. The nature of airborne LiDAR may render an overestimation bias of canopy cover. Pulses hitting non-foliar portions of a tree are recorded as non-ground return pulses, but these pulses should not be included in the estimation of canopy cover (Andersen et al., 2005).

Fuel Moisture and Climate Data

Fuel Moisture data, represented as integer percent values, established the initial moisture content of 1-, 10-, and 100-hour dead fuels, as well as the initial moisture content of live herbaceous and woody fuels, for each fuel model included in the analysis. In order to facilitate comparison between models, Scott & Burgan (2005) document standard moisture scenarios for both live and dead fuels. The most hazardous fuel moisture condition, D1L1, is chosen to simulate worst-case scenario impacts of wildfires. D1 represents dead fuels that have been conditioned by high-fire-prone weather. This may include low relative humidity, high temperature, and extended periods of sun exposure. L1 represents live fuels under the similar conditions, such that all live fuels are fully cured. Since live fuels are fully cured, the model is

robust to compare dynamic fuel models included in the Scott and Burgan 40 to static fuel models included in the Anderson 13. The resultant fuel moistures are listed in **Table D 15**.

Table D 15. Definition of initial fuel moisture file for extreme wildfire weather events

	D1 (Very Low) fuel moisture content (percent)	L1 (Fully Cured) Fuel Moisture Content (percent)
<i>1-hr</i>	3	-
<i>10-hr</i>	4	-
<i>100-hr</i>	5	-
<i>Live herbaceous</i>	-	30
<i>Live woody</i>	-	60

Relative humidity, temperature, and cloud cover are used to condition dead fuel moistures prior to the simulation of wildfire behavior. Wind speed and direction are used in calculation of flame length, rate of spread, and intensity (Finney, 2006). The inclusion of these variables is used to simulate future climate conditions to model the potential effects of climate change on wildfire behavior. Future conditions are represented under the assumption of present day conditions of vegetation and topography due to the uncertainty associated with changes in land cover. Local climate projections (1/16° degree) are derived from LOCA Downscaled Climate Projections processed as NetCDF from Cal Adapt, and used to model extreme conditions. Extreme conditions are modeled to simulate the most severe potential wildfire, since: 1) this is when catastrophic wildfires are most likely to occur, and 2) stakeholders should mitigate assuming worst case scenarios in order to sufficiently prepare for a wildfire near their assets (Keeley, 2004). The LOCA dataset is selected on the basis of its projection of extreme weather conditions; as opposed to a bias corrected statistical downscaling (BCSD) method that use averages and thereby overpredicts moderate conditions (e.g. over predicting drizzle as a result of aggregating precipitation and non-precipitation events), LOCA uses as analog to scale historical events (D. W. Pierce & Cayan, 2015; David W. Pierce et al., 2014).

For input to wildfire behavior modeling, extreme conditions are defined as the maximum temperature and minimum relative humidity for the given year, as well as the minimum temperature and maximum relative humidity that corresponded with a day that is projected to elicit the extreme conditions. An algorithm is developed that allows a user to input a year that corresponds to a stakeholder’s planning horizon, read extreme conditions of temperature and relative humidity from LOCA data for that year, and write the extreme conditions into a weather stream (.WXS) file that can be input into FlamMap for fuel conditioning calculations. Extreme wind conditions are modeled as foehn winds, and input to BFB as 30 miles per hour blowing downhill (Brinkmann, 1971).

D.3.7 Vegetation Management

There is a spectrum of vegetation management options effective at reducing fire hazards in California's forests, shrubland, and grassland areas (Agee, 2002; Cheney et al., 1993; Potts et al. 2010, Stephens et al., 2009). In order to reduce the exposure of TFS link and node assets to fire hazards, active vegetation management can achieve a desired level of exposure (Ager et al., 2010). In this section, we demonstrate how two vegetation management strategies: mechanical treatment and prescribed burn can be applied to a digital landscape and burned using FlamMap to show reductions in modeled fire behavior. While numerous studies have shown that the spatial pattern of vegetation has a significant impact on fire behavior and that operational, social and ecological issues are unique for each fuel treatment approach, the two fuel treatment models offer insights into how vegetation management can be modeled at a 5m spatial resolution to better understand how firefighter suppression and the protection of TFS link and node assets can be managed during a catastrophic wildfire.







Hazard Mitigation and Fuel Treatment Methods

When surface fires spread into tree canopies, the likelihood of spotting and mass fire increases (Stephens et al., 2018). To maintain control during an active wildfire, ladder fuels such as overgrown shrubs and tall grasses should be removed before ignition in order to prevent the transition from a surface fire to a canopy fire. For illustrative purposes, only the vegetative fuels within 60 ft (18.288 meters) of TFS link and node assets in Dutch Flat are modified. This buffer distance is selected to simulate a fuel treatment plan that achieves a safe and desirable containment area that reduces exposure and increases suppression control for firefighters.

A "Mechanical Removal of Vegetation" fuel treatment model is created to understand the fire behavior when all trees understories are mechanically thinned (**Table D 16a**), all shrubs masticated (**Table D 16c**) and all grass heights reduced and made discontinuous (**Table D 16d**). Mechanical removal by mastication is a process that reduces fuel loads but leaves moderate to low fuel loads, which may be sufficient for TFS link and node assets. Heavy machinery equipped with masticators grind live and dead standing fuels, to produce a fuel bed that reduces the heat intensity of catastrophic fires.

The "Prescribed Burn" fuel treatment model represents a hazard mitigation scenario in which trees have no understories (.b), all shrubs are masticated (.c), and all grass heights are reduced and made discontinuous (.d). Prescribed burns are designed to burn at low intensities and remove the majority of surface fuel loading. This approach significantly improves fire suppression efforts during catastrophic wildfires by reducing the intensity, size and damage of wildfires (Fernandes et al, 2003).

Table D 16. Fire Behavior Fuel Models Selected to Model Vegetation Management (Photo credit: Scott and Burgan, 2005).

	Tree Management	Shrub Management	Grass Management
Before	 "Timber Litter and Understory"; FBFM 10	 "Dormant Brush, Hardwood Slash"; FBFM 06	 "Short Grass"; FBFM 01
After	 "Low Load Humid Climate Timber - Grass - Shrub"; FBFM 162	 "Low Load Compact Conifer Litter"; FBFM 181	 "Low load Activity Fuel"; FBFM 201
	(a)	(b)	(c)
		 "Short, Sparse Dry Climate Grass"; FBFM 101	(d)

Interpretation of Exposure to Substantial Hazards - Flame Length

As discussed in Chapter 3.2.2., modeled flame lengths are a useful proxy for understanding the degree of firefighter control. In **Table D 17.**, the flame lengths for the "No Treatment", "Mechanical Removal of Vegetation", and "Prescribed Burn" models are shown. A "No Treatment" model is used to demonstrate a current scenario where no vegetation is modified and the landscape experiences a wildfire driven by catastrophic wildfire conditions. In **Table D 17.a**, it's distribution of flame length exposure to the stretch of pipeline in this area has over 15,000 sq.m. of extreme flame lengths and 4000 sq.m. of high flame lengths. In this location, we

describe the exposure of modeled behaviors by area of substantial hazards, such that any behavior classified as “High” or “Extreme” will give firefighter’s substantial control difficulty.

$$A_{SH} = (A_E + A_H) / A_T \quad (1)$$

Where

A_{SH} = Area of Substantial Hazard (%),

A_E = Area of Extreme (sq.m),

A_H = Area of High (sq.m.), and

A_T = Total Area (sq.m.)

TFS link and node assets exposed to a large % of substantial hazards may seek to improve their vegetation management strategies. Under the “Not Treatment” scenario, this selected stretch of pipeline is exposed to 83% substantial flame length hazards, therefore it is a likely candidate for vegetation management.

In **Table D 17.b**, the “Mechanical Removal of Vegetation” model has a greater reduction in exposure to substantial fire hazards as compared to the “No Treatment” model. Within the 60’ buffer around the pipeline, there are 10,000 sq.m. of extreme flame lengths and under 1,000 sq.m. of high flame lengths. This vegetation management strategy leaves the pipeline exposed to 41% substantial flame lengths, which may be desirable when considering heat exposure thresholds.

In **Table D 17.c**, the “Prescribed Burn” model has an even greater reduction in exposure to substantial fire hazards compared to the other models, with a 13% exposure to substantial flame lengths. Within 60’ of the pipeline, about 3,000 sq.m. express extreme flame lengths and almost no high flame lengths. Compared to the “Mechanical Removal of Vegetation” model, this management approach may be more desirable around vulnerable TFS link and node assets.

When comparing the distributions of exposure to flame lengths, modeling demonstrates how different treatment options have different outcomes for reducing potential hazards and some amount of fuel treatment is better than no vegetation management. More specific vegetation management approaches can be used to optimize defensible spaces for wildland firefighters.

Table D 17. Exposure of A Stretch of Pipeline to Modeled Flame Lengths Under Vegetation Management Strategies.

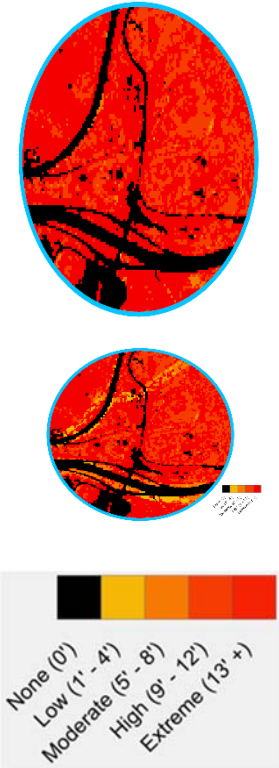
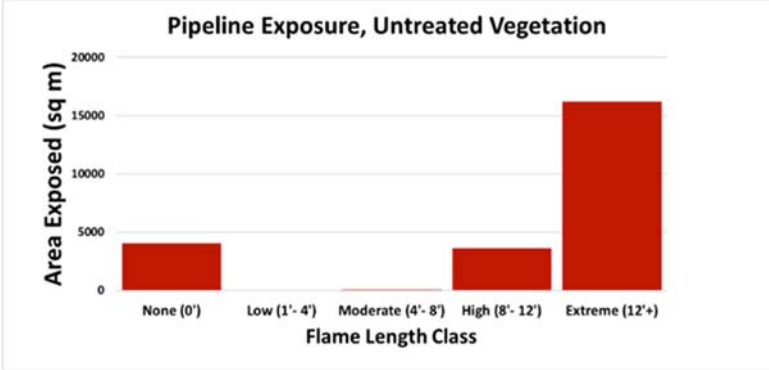
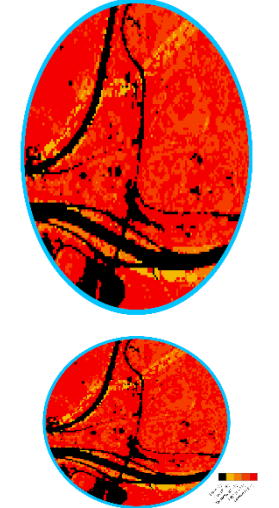
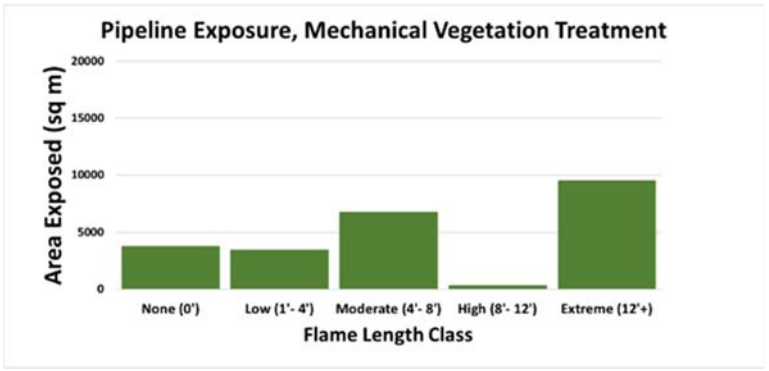
	Flame Length	Distribution of Flame Length Exposure												
(a) No Treatment		 <table border="1"> <caption>Pipeline Exposure, Untreated Vegetation</caption> <thead> <tr> <th>Flame Length Class</th> <th>Area Exposed (sq m)</th> </tr> </thead> <tbody> <tr> <td>None (0')</td> <td>~4,000</td> </tr> <tr> <td>Low (1'- 4')</td> <td>0</td> </tr> <tr> <td>Moderate (4'- 8')</td> <td>0</td> </tr> <tr> <td>High (8'- 12')</td> <td>~4,000</td> </tr> <tr> <td>Extreme (12'+)</td> <td>~16,000</td> </tr> </tbody> </table>	Flame Length Class	Area Exposed (sq m)	None (0')	~4,000	Low (1'- 4')	0	Moderate (4'- 8')	0	High (8'- 12')	~4,000	Extreme (12'+)	~16,000
Flame Length Class	Area Exposed (sq m)													
None (0')	~4,000													
Low (1'- 4')	0													
Moderate (4'- 8')	0													
High (8'- 12')	~4,000													
Extreme (12'+)	~16,000													
(b) Mechanical Removal		 <table border="1"> <caption>Pipeline Exposure, Mechanical Vegetation Treatment</caption> <thead> <tr> <th>Flame Length Class</th> <th>Area Exposed (sq m)</th> </tr> </thead> <tbody> <tr> <td>None (0')</td> <td>~4,000</td> </tr> <tr> <td>Low (1'- 4')</td> <td>~4,000</td> </tr> <tr> <td>Moderate (4'- 8')</td> <td>~7,000</td> </tr> <tr> <td>High (8'- 12')</td> <td>0</td> </tr> <tr> <td>Extreme (12'+)</td> <td>~10,000</td> </tr> </tbody> </table>	Flame Length Class	Area Exposed (sq m)	None (0')	~4,000	Low (1'- 4')	~4,000	Moderate (4'- 8')	~7,000	High (8'- 12')	0	Extreme (12'+)	~10,000
Flame Length Class	Area Exposed (sq m)													
None (0')	~4,000													
Low (1'- 4')	~4,000													
Moderate (4'- 8')	~7,000													
High (8'- 12')	0													
Extreme (12'+)	~10,000													

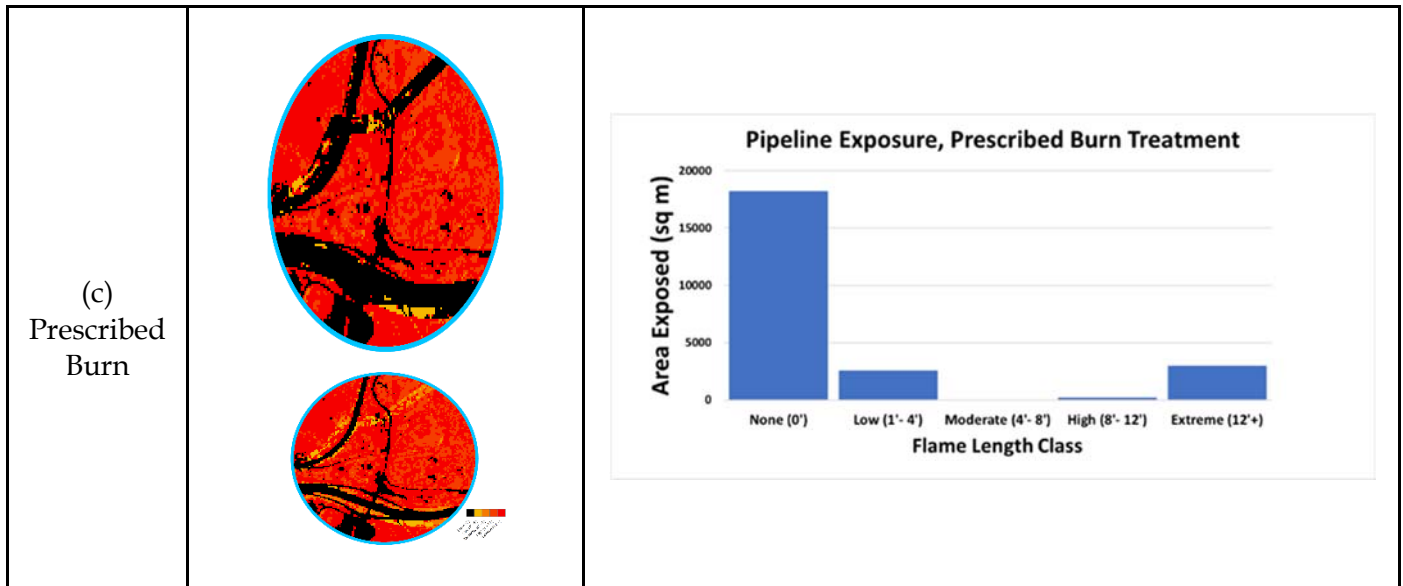

Comparing Selected Fire Behavior Fuel Models

The Fire Characteristics Chart discussed in Appendix D 3.3 is also useful for comparing the fire behavior of different fuel models burned under the same fire simulation conditions. In **Figure D 34**, the three vegetation management strategies are compared. This chart demonstrates the importance in selecting the appropriate fuel models for achieving the desired modeling vegetation management.

The FBFMs of the “No Treatment” are selected from the Anderson 13 and the treatment FBFMs are selected from the S&B 40. For both treatment scenarios, “Low Load Activity Fuel” (FBFM 201) and “Short, Sparse Dry Climate Grass” (FBFM 101) are used to represent the shrub and grass classes, respectively. These fuel models simulate the results of a mastication and grass removal process and a prescribed burn process. The two mitigation strategies differed by the tree fuel model used. For the mechanical removal mitigation strategy, trees are represented by “Low Load Humid Climate Timber-Grass-Shrub” (FBFM 162). This fuel model is chosen to include some low load understory with humid climate vegetation. To simulate the removal of all non-leaf litter vegetation, “Low Load Compact Conifer Litter” (FBFM 181) is used to model a prescribed burn strategy.

In addition to **Table D 17**, we also compare the fuel models in the Fire Characteristics Chart below. The Fire Characteristics Chart shows the expected suppression response based on the fire behavior observed in the three scenarios. The “No Treatment” simulation yields fire intensity (heat per unit area) and flame length to a degree where one would expect an indirect suppression response, rendering the asset vulnerable to direct heat exposure without firefighter intervention. The simulation shows “Mechanical Treatment” fuel models reduce wildfire behavior such that the area could be defensible by wildland firefighters equipped with heavy machinery. Finally, wildfire behavior is reduced in the “Prescribed Burn” simulation to a low magnitude that is defensible by hand crews.

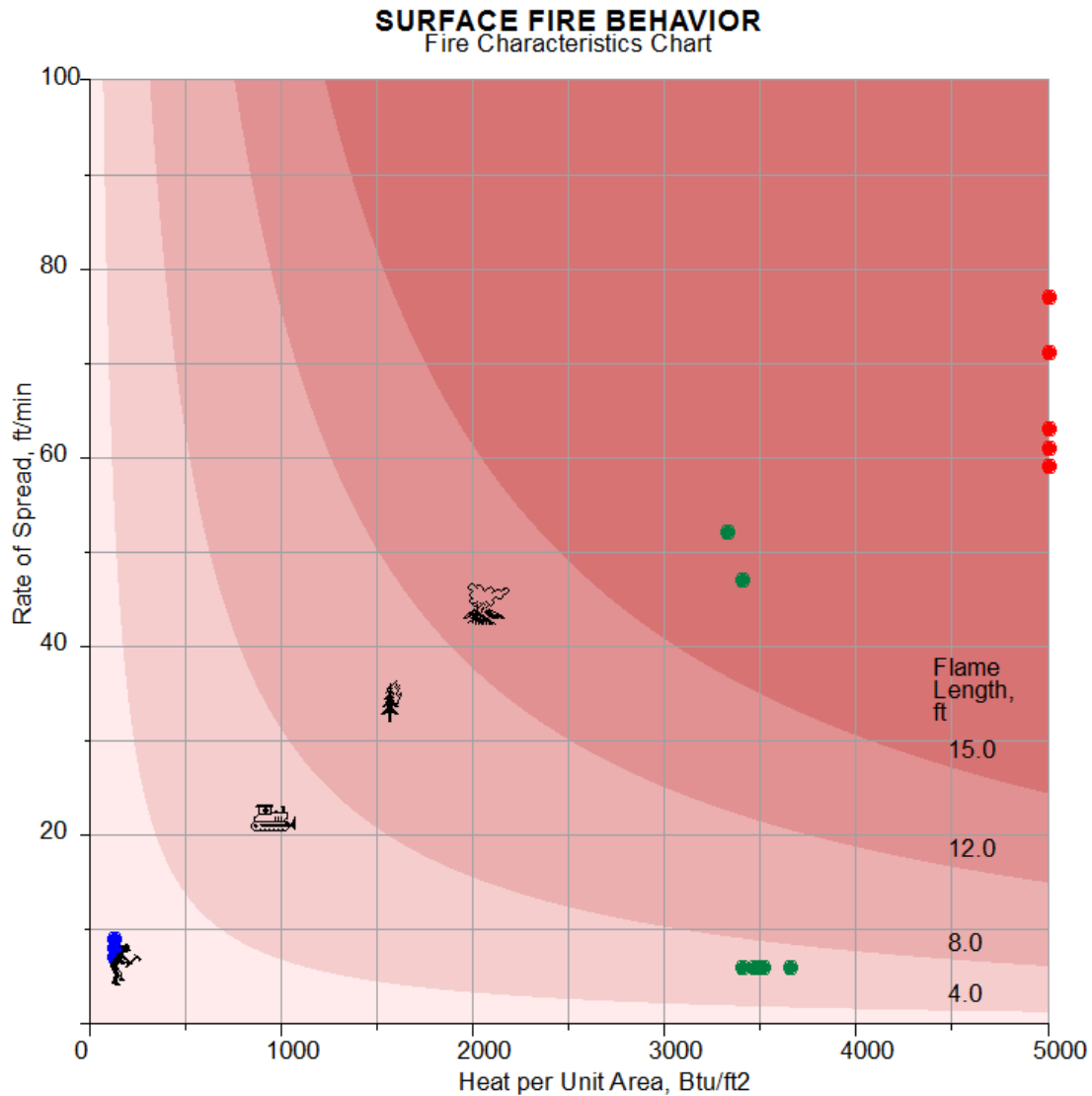

Figure D 34. Fire Characteristics Chart with plotted points from three strategies: No Treatment, Mechanical Removal of Vegetation, and Prescribed Burn. Note that points from the No Treatment strategy are plotted off the chart, with Heat per Unit Area values ranging from 6,000 to 8,000 BTU/ft².

D.3.8 High Resolution Wildfire Modeling Results

D.3.8.1 Comparison to LANDFIRE

This section examines the similarities and differences between the static, maximum potential fire behavior of the burnable fuels at 30 m (98.4 ft) and 5m (16.4 ft) across the landscape of Dutch Flat (**Figure D 36** through **Figure D 39**). Dutch Flat is an unincorporated community in Placer County that has a history of wildfire. Analyzing a potential wildfire disruption in this

location is useful to demonstrate the benefits of using high-resolution data over medium resolution data for wildfire modeling TFS infrastructure. Within Dutch Flats, there is a convergence of three TFS infrastructure types that regularly distribute fuels: highway, railway, and pipeline. In our 5-m (16.4-ft) data products (**Figure D 35**) TFS assets are clearly present, while the 30-m (98.4-ft) land cover classification data products may omit or confuse the critical fuels surrounding TFS assets (**Figure D 36**). Comparing the 5m to 30m resolution land cover demonstrates the increased benefits of higher spatial resolution imagery for detecting fuel complex characteristics around TFS assets.

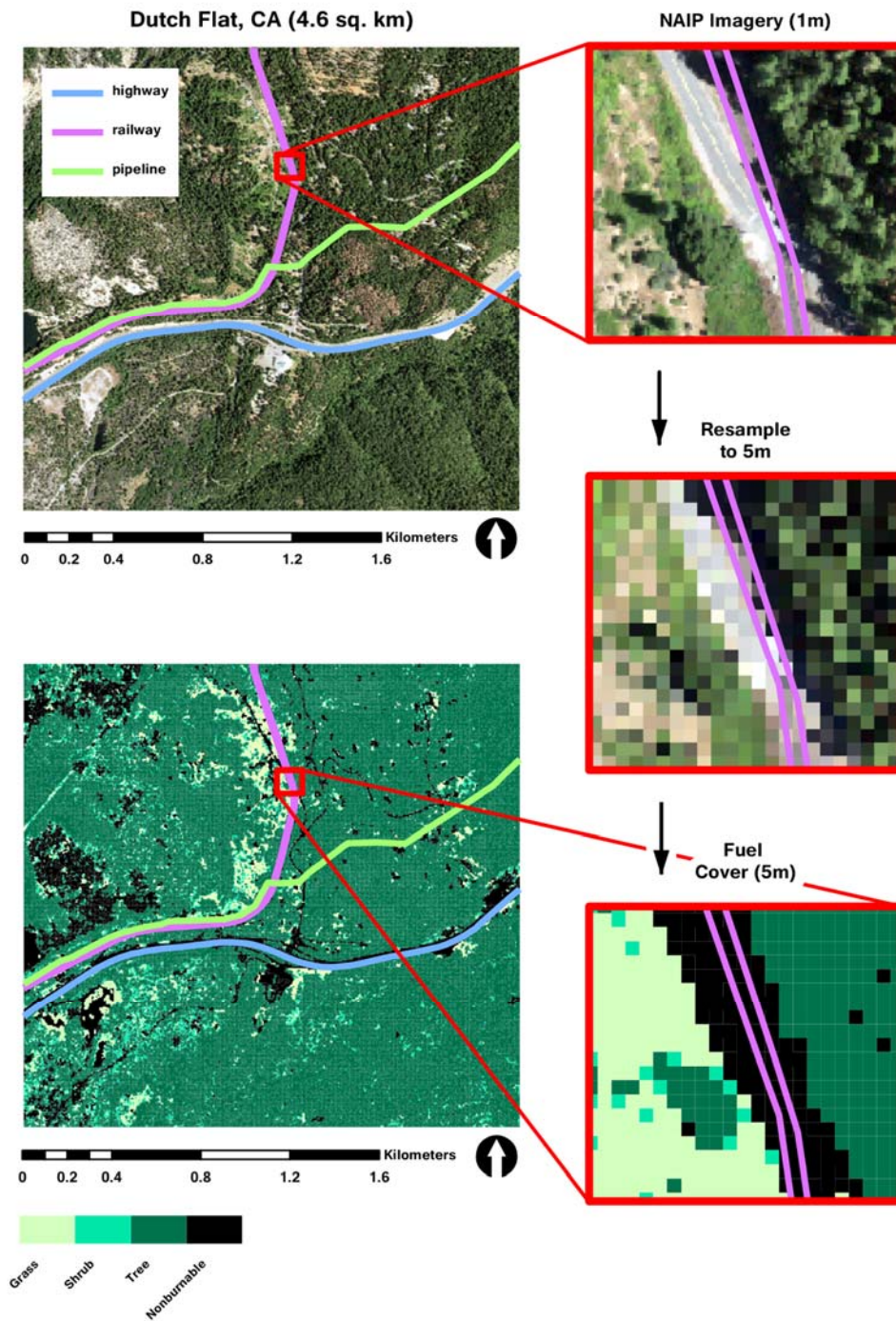

Figure D 35: Highway, railway, and pipeline are displayed in green, blue, and pink, respectively in the high-resolution aerial imagery (top) and land cover model (bottom). Vegetation, landscape features, and fuel breaks can be seen in the aerial image. To its right is a zoomed-in image of the railway, with its tracks and gravel seen in gray and the green vegetation surrounding it. In the event of a wildfire, this railroad would act as a fuel break and provide a location for firefighters to suppress fire. Using high spatial resolution data, we created a 5-m (16.4-ft) land cover model. In the 5-m (16.4-ft) land cover model, desired fuel breaks are represented in black. The accuracy of mapped fuel cover is 91.25% (see **Table D 18**).

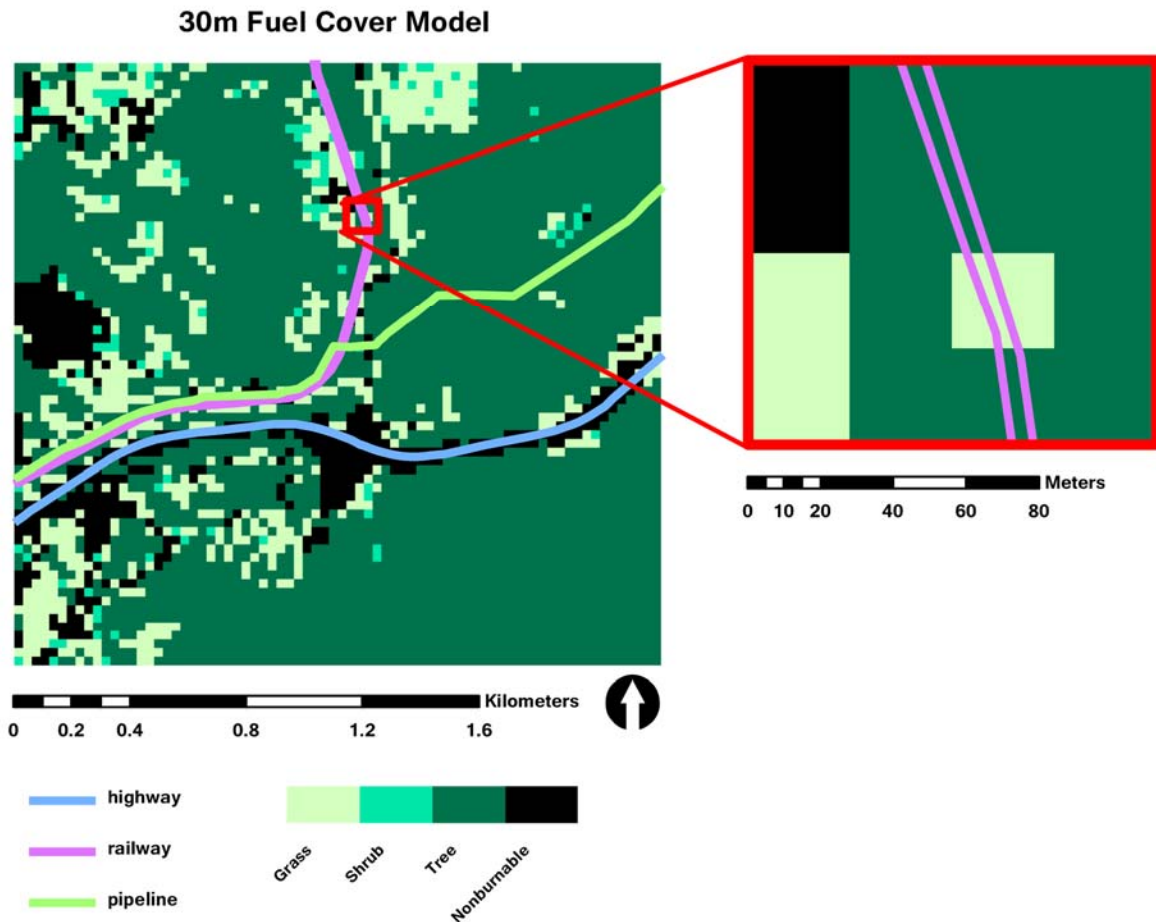

Figure D 36: Using a 30-m (98.4-ft) fuel model product from LandFire, we created corresponding land cover at 30-m (98.4-ft). Because 30-m (98.4-ft) pixels assign a single value to a large area, the railway and surrounding critical fuel break are absent from the dataset. The accuracy of mapped fuel cover at 30 m (98.4 ft) is 48.75%.

The primary trade-offs between medium (30-m; 98.4-ft) and high (5-m; 16.4-ft) resolution wildfire modeling concern the accuracy of land cover classifications. Land cover classified at a 30-m (98.4-ft) spatial resolution is useful for regional fuel estimates, where the variability of local scale information does not critically impact regional fire suppression or mitigation efforts. The 30-m (98.4-ft) land cover classifications from LandFire are a standard data product used by fuel managers and others in the field of wildfire modeling. This data is best used for regional analyses where fire management strategies are more focused on containing large, active wildfire perimeters and allocating fire suppression specialists. Land cover classified at 5-m (16.4-ft) spatial resolution is useful for local scale fire behavior estimates where the fire behavior of individual objects is important in decision making and especially relevant for planning fuel breaks and fuel treatments.

We conduct an accuracy assessment of the vegetation classification for the 5-m (16.4-ft) data (**Table D 18**) and the 30-m (98.4-ft) data (**Table D 19**). As expected there is a remarkable difference in accuracy between these two products. The User's accuracy represents the probability that a pixel predicted to be a certain class really is that class. Producer's accuracy is the probability that a pixel in a given class is correctly classified. Both the User's and Producer's accuracy are 20-60 or more points higher for the 5-m (16.4-ft) data. This is not surprising since 30-m (98.4-ft) pixels often are "mixed" pixels meaning that they are comprised of one or more land cover classes. So, the accuracy of classification for the 30-m (98.4-ft) pixels would be expected to be less than for 5-m (16.4-ft) pixels.

Table D 18: Accuracy tables for 5m land cover classification using stratified random sample of validation points. The overall accuracy of land cover classification is 91.25%.

Classes	Grass	Shrub	Tree	Non-burnable	User's Accuracy (%)
Grass	57	1	3	1	92.94
Shrub	0	30	0	3	90.91
Tree	0	0	57	0	100
Non-burnable	8	3	2	75	85.23
Producer's Accuracy (%)	87.69	88.24	91.94	94.94	91.25

Table D 19: Accuracy tables for 30m land cover classification using stratified random sample of validation points. The overall accuracy of land cover classification is 48.75%.

Classes	Grass	Shrub	Tree	Non-burnable	User's Accuracy (%)
Grass	19	10	6	12	40.43
Shrub	4	1	0	4	11.11
Tree	29	20	53	19	43.80

Non-burnable	13	3	3	44	69.84
Producer's Accuracy (%)	29.23	2.94	85.48	55.70	48.75

Assessing the impacts of a hazard requires a defined spatial scale. In this area of Dutch Flat, an intermix of tall grasses, shrubs, and conifer trees sitting on steep slopes with a southward facing aspect can produce extreme fire behaviors that can disrupt the movement of fuels along railway, pipeline, and highway. When comparing the potential fire behavior of the same area, but at different spatial resolutions, the higher resolution data product we created shows a greater range and higher precision mapping of predictable fire behaviors. **Figure D 37** shows the effect of spatial scale on flame length. With 5-m (16.4-ft) resolution data, the railroad line is better identified and leads to a NE to SW area of zero flame length. But with the 30-m (98.4-ft) resolution imagery the railroad line is not well identified. At this spatial resolution the fire models predict flame length of 0.30-1.22 m (1-4 ft) owing to the fact that at 30 m (98.4 ft) there are mixed pixels that have both railroad and vegetation. The same pattern is show with rate of spread and fire intensity in **Figure D 38** and **Figure D 39**, respectively.

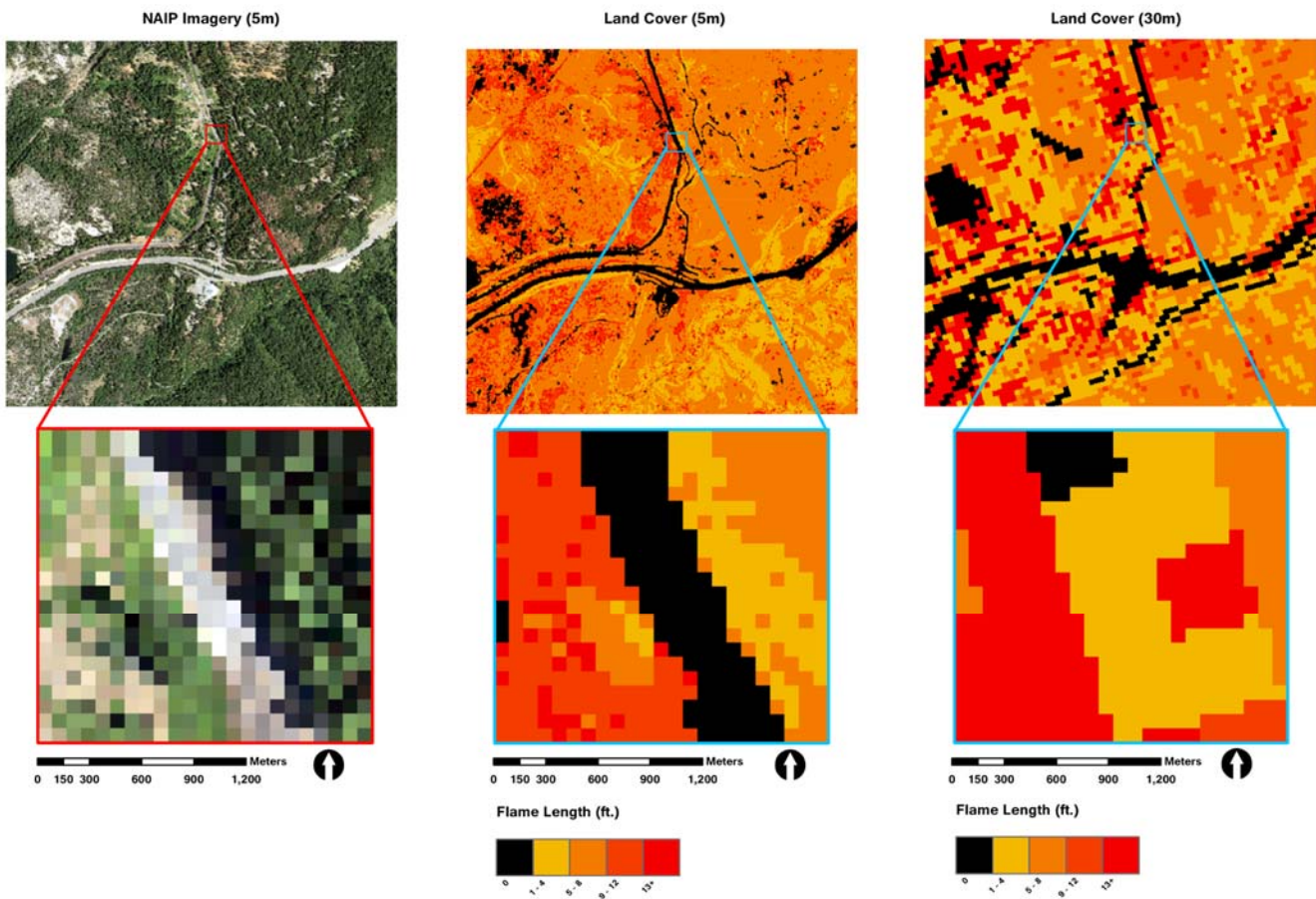

Figure D 37: NAIP imagery (left), 5-m (16.4-ft) maximum potential flame lengths (middle) and 30-m (98.4-ft) maximum potential flame lengths (right). The railroad does not ignite under these conditions and its benefits as a fuel break are observed.

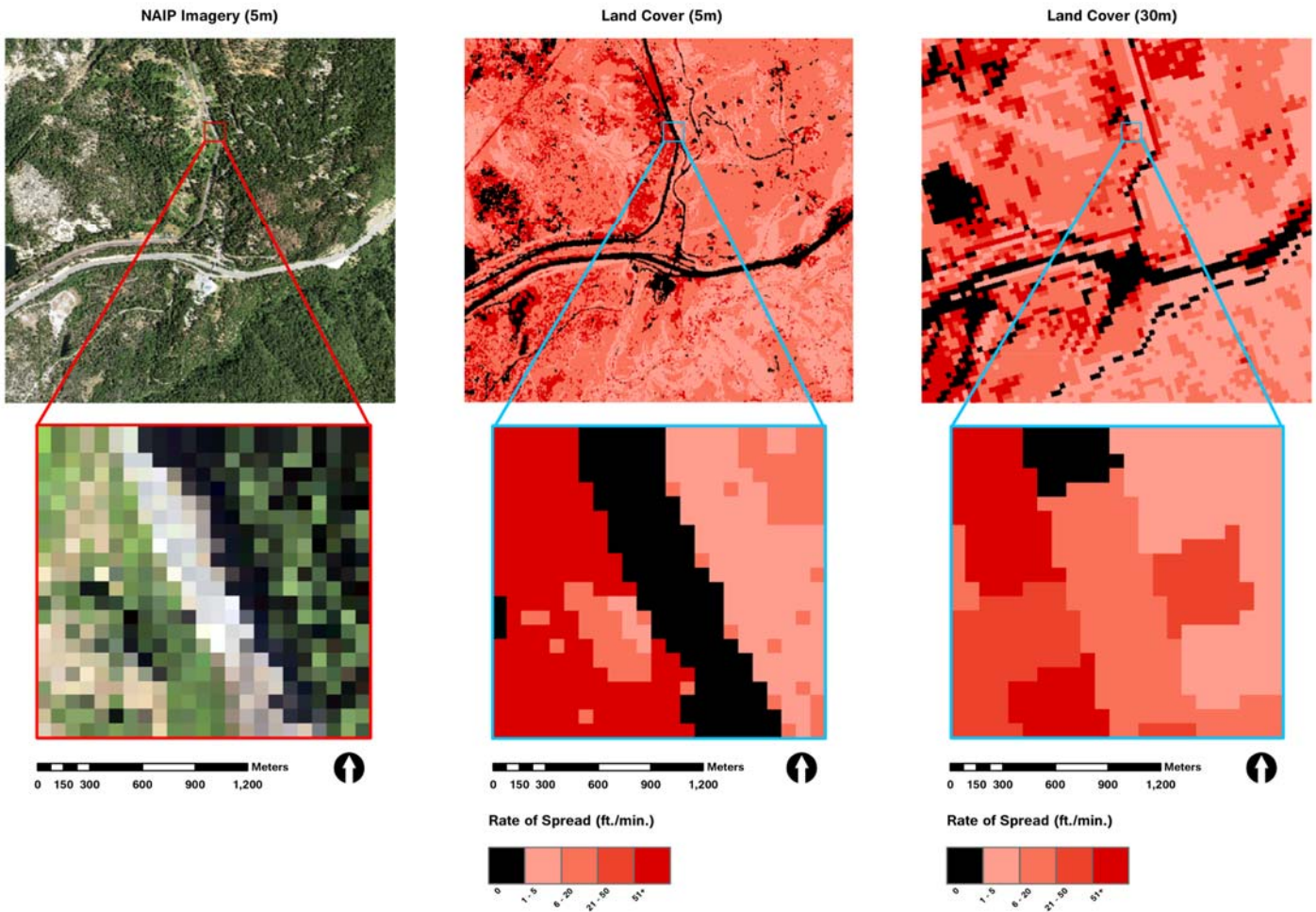

Figure D 38: NAIP imagery (left), 5-m (16.4-ft) maximum potential rates of spread (middle) and 30-m (98.4-ft) maximum potential rates of spread (right).

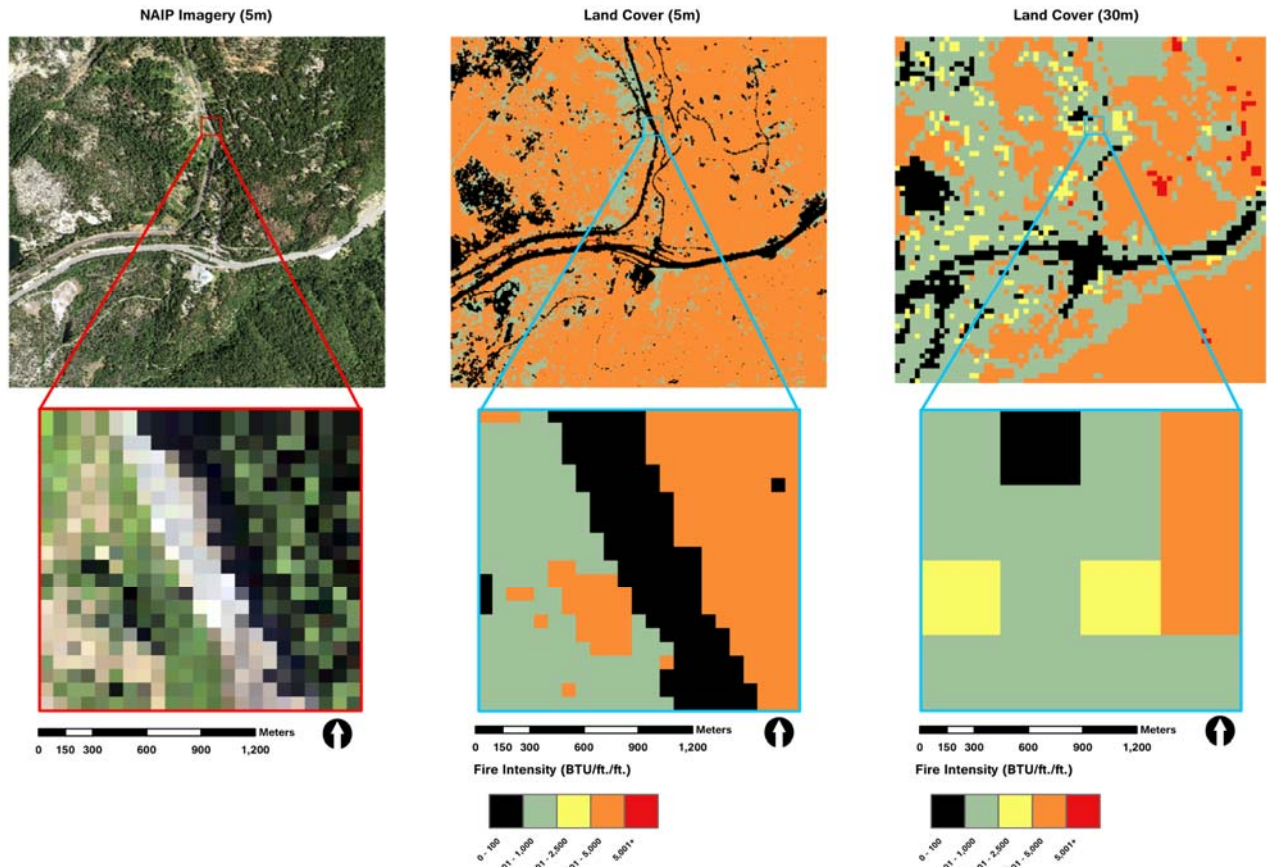

Figure D 39. NAIP imagery (left), 5-m (16.4-ft) maximum potential fire intensity (middle) and 30-m (98.4-ft) maximum potential fire intensity (right).

D.3.8.2 Future Projections of Wildfire Behavior

This section examines the modeled fire behavior of simulated future climate conditions from the periods between 2020-2100 for Dutch Flat, California. The results suggest that wildfire behaviors depend more strongly on topography and vegetation type than on the fuel conditioning effects of pre-fire temperature and relative humidity. The primary driver of future changes in wildfire behavior will be land cover. In other words, human development and vegetation succession. TFS planning for future wildfire should, therefore, consider changes in location and frequency of large wildfires, as suggested by the regional resolution analysis in Appendix D.2.

The following graphics show changes in wildfire behavior in the study site from the periods 2020-2100 for 8 future weather scenarios. These future weather scenarios change how fuels are conditioned, from changes in relative humidity and temperature, in the moments leading up to a wildfire event. Across all 8 future conditions from the periods 2020-2100, the wildfire behaviors (fire intensity, flame length, and rate of spread) do not show any significant changes. As part of our procedure we choose to model extreme conditions - maximum temperature and minimum relative humidity for the given year (**Figure D 40**). The findings in **Table D 20** suggest that this methodology elicited conditions that did not change appreciably over the 8 future

weather scenarios. That is, similar extreme weather conditions are a feature of all 8 future weather scenarios.

Table D 20: Future Weather Scenarios that are standard for California’s Fourth Assessment on Climate Change.

	Scenarios							
	1	2	3	4	5	6	7	8
GCM	CanESM		CNRM-CM5		HadGEM2-ES		MIROC5	
RCP	4.5	8.5	4.5	8.5	4.5	8.5	4.5	8.5

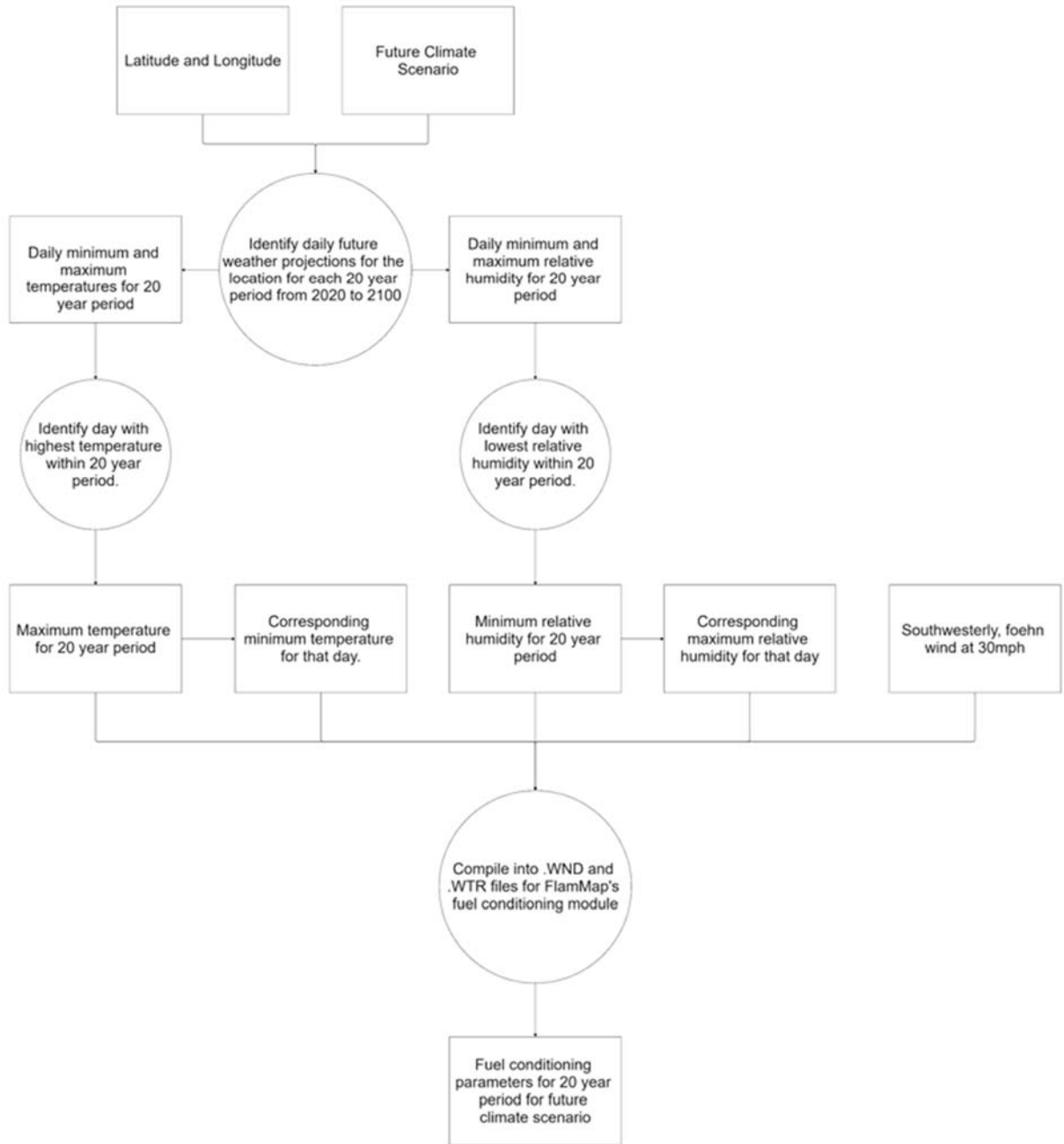

Figure D 40: The process for creating fuel conditioning parameters for the future climate scenarios from LOCA data involves extracting the daily weather conditions for each 20-year period, identifying the maximum high temperature and corresponding daily minimum, the minimum relative humidity and corresponding daily high, and coupling this with constant wind conditions.

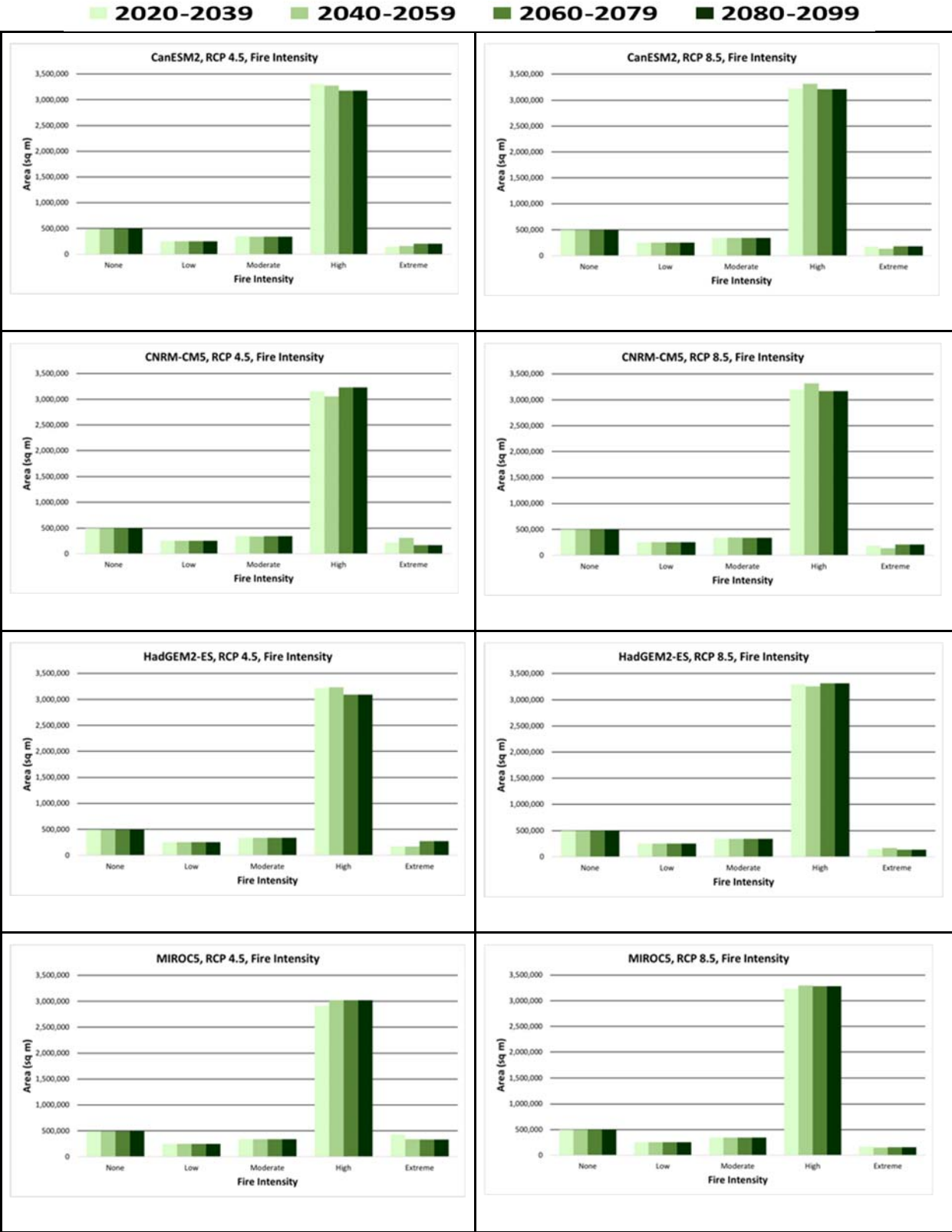

Figure D 41: Modeled Fire Intensity for 8 future scenarios for the periods 2020-2039, 2040-2059, 2060-2079, and 2080-2099.

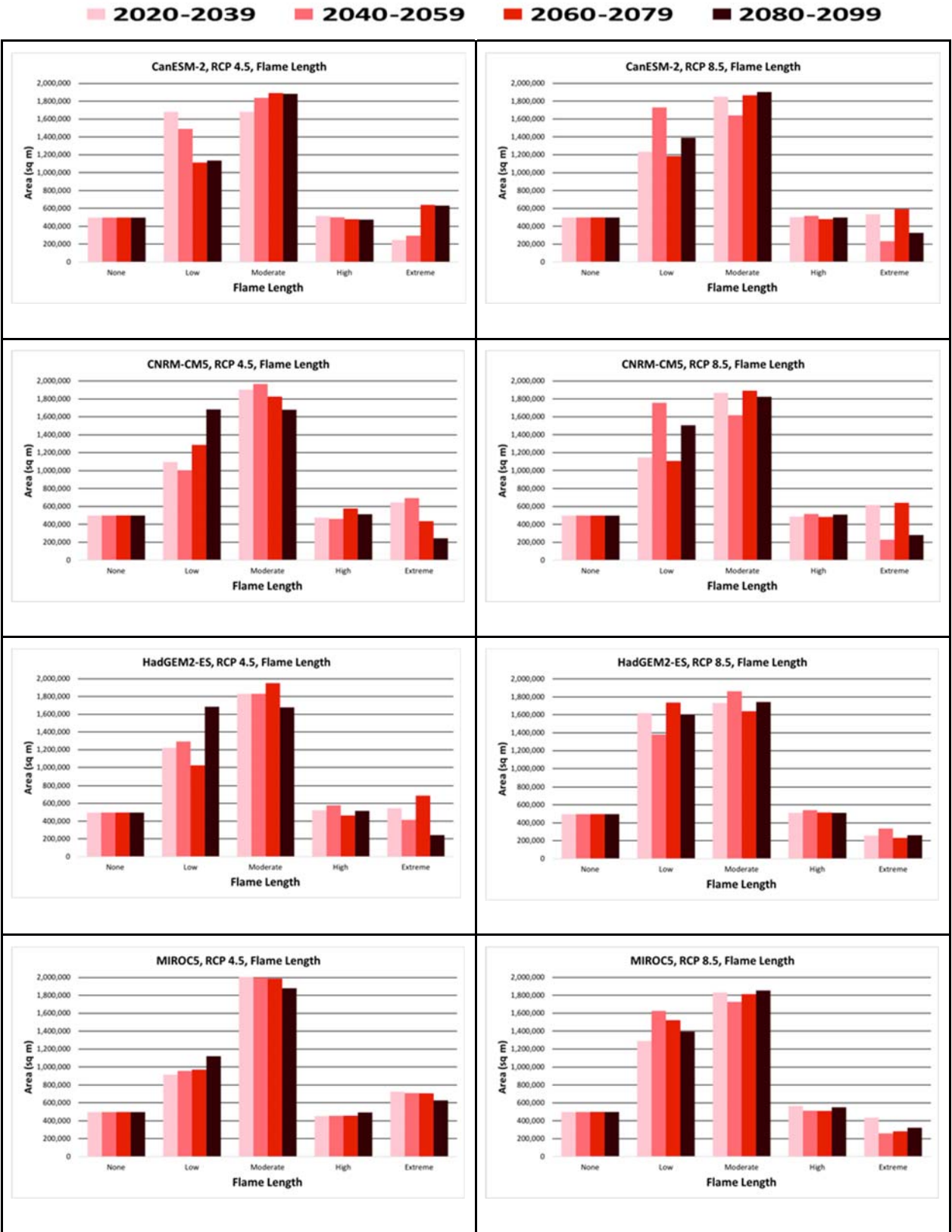

Figure D 42: Modeled Flame Length for 8 future scenarios for the periods 2020-2039, 2040-2059, 2060-2079, and 2080-2099.

2020-2039 2040-2059 2060-2079 2080-2099

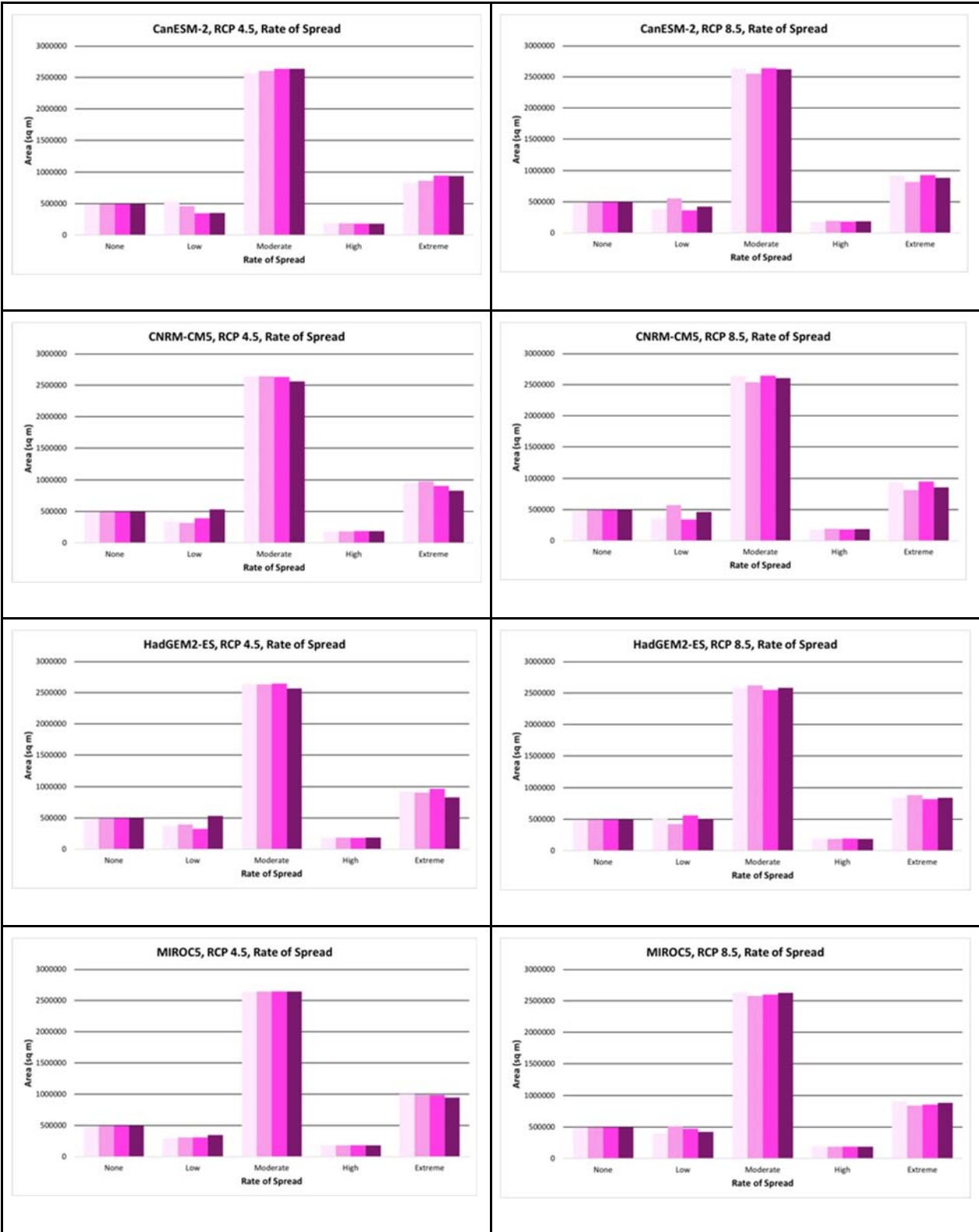

Figure D 43: Modeled Rate of Spread for 8 Future Scenarios for the periods 2020-2039, 2040-2059, 2060-2079, and 2080-2099.

D.3.9 Model Validation

Wildfire behavior metrics are useful tools to assess wildfire hazard, but validation of these metrics is a necessary component of analysis to ensure the accuracy, and thereby applicability, of high spatial resolution wildfire behavior modeling. Validation of wildfire behavior estimation is difficult, considering the discrepancy of priority during an active fire between firefighting and research-oriented data collection. There are no precise spatial measurements at large scale of observed fire intensity, flame length, or rate of spread. Therefore, a novel approach to validating the fire intensity metric is conducted using observed data from both during and after a recent wildfire in Sonoma County, the Tubbs Fire.

In this section, an area from a recent California wildfire, the October 2017 Tubbs Fire, is used for a two-part validation. In the first section is an accuracy assessment for the land cover in the region, yielding 93.07% overall accuracy. The following section is a validation for the fire intensity behavior metric modeled using FlamMap 5.0. The validation uses a multinomial logit regression to evaluate the correlation of estimated fire intensity with soil burn severity (SBS), an observed categorical outcome variable. The regression indicates a statistically significant correlation between the two variables, such that a higher estimate of fire intensity tends to correspond with greater SBS.

D.3.9.1 Land Cover Classification Accuracy Assessment

A 37 sq. km (14.29 sq. mile) study site within the Tubbs Fire perimeter is used for this analysis (**Figure D 44** left). This is a wildland-urban interface area with an intermix of impervious surfaces, oak and fir trees, shrubs, grass, perennial agriculture (vineyards), and ponds. NAIP imagery from 2009 and LiDAR from 2003 are used to create a 5-m (16.4-ft) land cover model (**Figure D 44** right). The classification results achieved an overall accuracy of 93.07% (**Table D 21**).

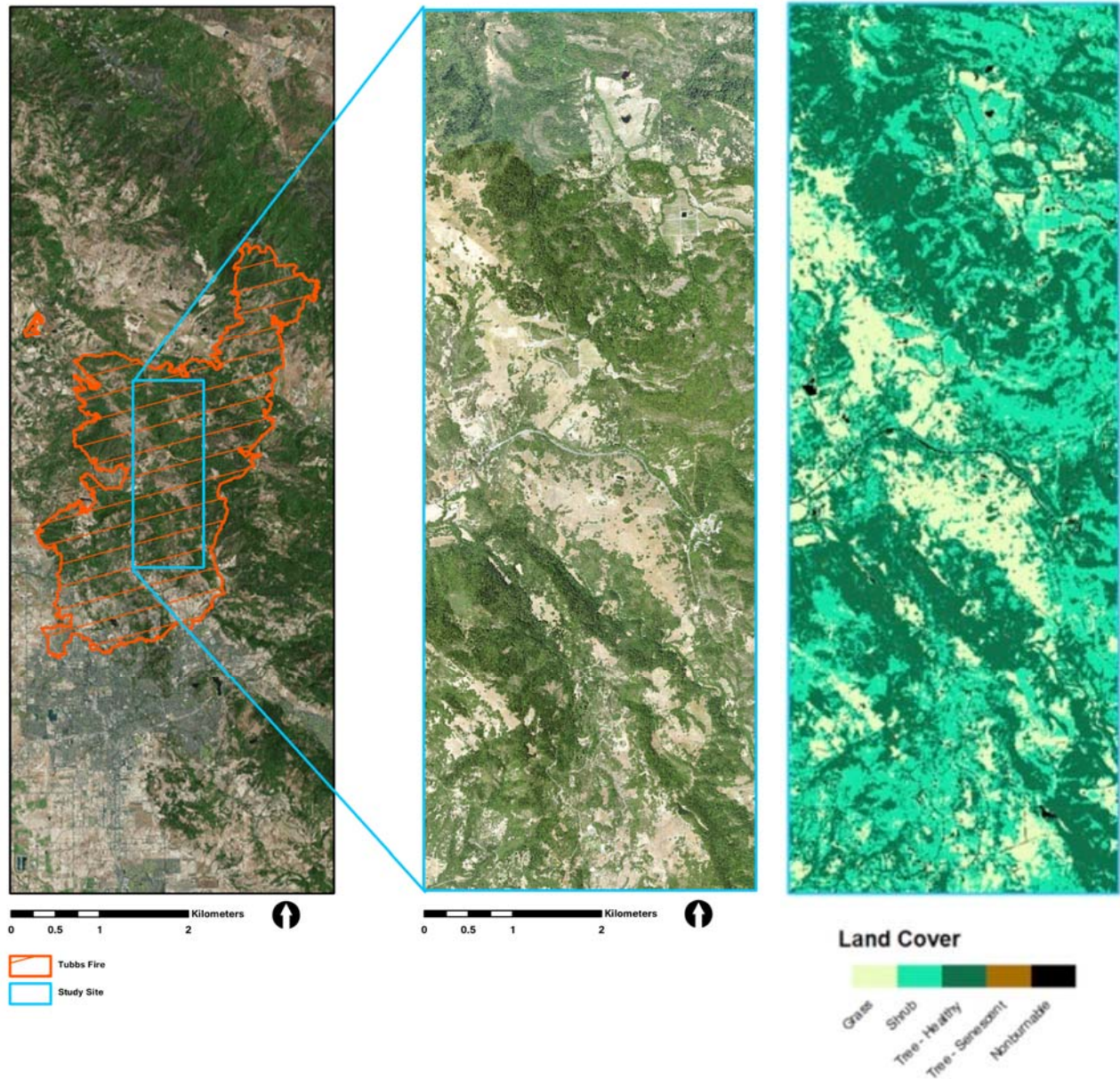

Figure D 44: Map showing study site within the Tubbs Fire perimeter (left), NAIP imagery (middle) and land cover classified at 5 m (16.4 ft) (right)

Soil Burn Severity (SBS) is a measure of the relative changes in soil organic matter or deposition of ash from the above ground combustion of biomass (Lewis, Wu, & Robichaud, 2006). After a wildfire event, a Burned Area Emergency Response (BAER) team assesses the degree of biomass lost and classifies the post-fire soil conditions using the Burned Area Reflectance Classification (BARC). Soil conditions are classified to indicate the relative changes in pre- and post-fire soil conditions. While Vegetation Mortality data from a Rapid Assessment of Vegetation Condition after Wildfire (RAVG) would be ideal for this comparison to land cover, this data is not collected at a high enough spatial resolution. Instead, comparing SBS to land cover is useful to make the case that land cover contributed to SBS measurements.

Table D 21: Accuracy tables for 5-m (16.4-ft) land cover classification using stratified random sample of validation points. The overall accuracy of land cover classification is 93.07%.

Classes	Grass	Shrub	Tree	Non-burnable	User's Accuracy (%)
Grass	96	1	1	4	94.12
Shrub	4	95	1	0	95.00
Tree	0	2	100	0	98.04
Non-burnable	8	7	0	85	85
Producer's Accuracy (%)	88.89	90.48	98.04	95.51	93.07

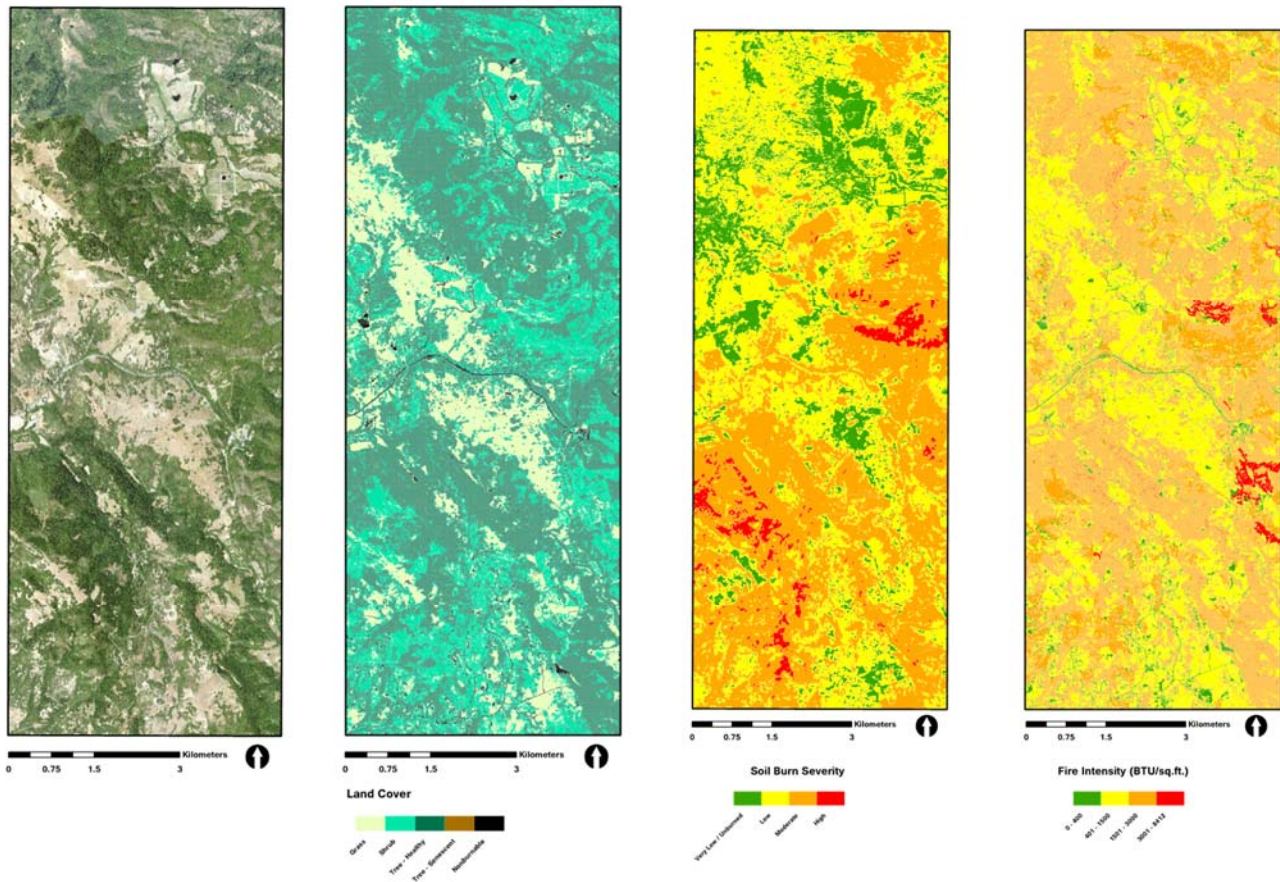

Figure D 45: The areas burned by the Tubbs Fire were shrub-dominated (NAIP imagery (left) and 5m land cover (middle left)). When comparing land cover with Soil Burn Severity, we can see that soil burn severity is generally moderate for shrub areas. Healthy trees have both moderate and high soil burn severity in the southern portion of the study area. In the northern portion healthy trees experience very low-to-moderate soil burn severity. When comparing the SBS (middle right) and fire intensity (right) graphics, there appears to be a geographical relationship worthy of investigating.

D.3.9.2 Wildfire Behavior Validation for the Fire Intensity Metric

According to the logit analysis, higher fire intensity is associated with a greater likelihood of “Moderate” and “High” soil burn severity (SBS). While a lack of observed fire intensity data complicates a precise validation of the fire intensity metric, studies have indicated a positive correlation between fire severity and fire intensity (Keeley, 2009). This analysis attempts to tease out this correlation in observed and modeled data, and indicates modeled fire intensities may resemble those observed during the Tubbs Fire.

Scope of Analysis

The fundamental idea of the validation is that, though imperfectly, fire intensity should be directly correlated with SBS. The validation of fire intensity hinged on two key observed datasets from the Tubbs Fire: thermal infrared data recorded during the active fire and a soil burn severity analysis produced after the fire. Thermal infrared data is a spatial point dataset indicating which locations are confirmed to have burned during the fire. The thermal infrared data enabled the analysis to validate only estimations for areas confirmed to have burned, allowing the analysis to sidestep the assumption of FlamMap BFB simulator that the full input surface burns. Soil burn severity data, the other key observed dataset, is a sub-optimal yet serviceable dependent variable influenced by fire intensity.

The following regression equation is proposed, with the aim of creating a predictive model for observed soil burn severity with all observed independent variables, aside from the estimated fire intensity:

$$(\text{soil burn severity}) = \alpha + \beta_0(\text{fire intensity}) + \beta_1(\text{slope}) + \beta_2(\text{elevation}) + \beta_3(\text{soil type}) + \beta_4(\text{solar radiation}) + \beta_5(\text{OSAVI})$$

The analysis supposes that if the predictive equation is statistically significant, and estimated fire intensity is a statistically significant predictor of soil burn severity, then estimated fire intensities may be similar to those elicited during the Tubbs Fire. The multinomial logit regression is used over ordinary least squares regression because the outcome variable, SBS, is categorical. An ordinal multinomial logit analysis is not used because the precise distinctions between classes of SBS are not recorded.

As for expectations of the overall fit of the equation, it is well documented that fire intensity is not perfectly correlated with SBS. Soil moisture and random flame activity have a greater effect on SBS than do fire intensity (Keeley, 2009; Marion, 1991). Therefore, expectations of a confirmatory analysis are a relatively low McFadden pseudo-R² for a statistically significant equation and statistically significant dependent variables. In other words, the predictive equation could not possibly predict soil burn severity with great confidence, but ideally would consistently explain some proportion of the variation in soil burn severity.

Data and Variables Included in the Analysis

Table D 22: Data Used in Multinomial Logit Regression Analysis

Variables	Geographic Data	Description
Dependent	Soil Burn Severity (SBS)	SBS is a post-wildfire product constructed by a private contractor. The conventional goal of SBS data is to detect implications on vegetation succession and watershed recovery, so it is being repurposed for this analysis. SBS is generated by collecting field samples of soil burn severity, processing an image enhancement, and using the field samples to threshold the image enhancement. Fortunately for our analysis, the original SBS data was constructed at 5 meter resolution, the same as our fire intensity and topography models.
Independent	Fire Intensity (Model Estimated)	Fire intensity is strongly influenced by the vegetation type and fuel moisture, such that grasses are known as 1-hr fuels, shrubs are typically 10 to 100-hr fuels, and trees are 1000-hr fuels. Fire intensity is the energy emitted per unit area.
	Slope	Wildfire behaviors such as flame length and rate of spread are strongly influenced by slope since heat rises, causing vegetation on steeper slopes to be pre-cooked from upward moving radiation. A steeper slope may indicate greater flame contact with soil, and thereby greater SBS.
	Elevation	One of a series of variables used to internalize soil moisture, which should be a correlate of soil burn severity. Higher elevation should roughly correlate with lower soil moisture, and therefore greater soil burn severity, based generalizations of the subsurface water table.
	Soil Type	Various soil types have different water holding capacities. Drier soils typically experience greater soil burn severities. Soil types were acquired from Soil Survey Geographic Database (SSURGO) soil surveys and separated into 9 soil types based on the basic soil classes.
	Solar Radiation	Fuel and soil moistures are drier on south facing aspects and wetter on north facing aspects in the Northern Hemisphere. Solar radiation is a measure of solar energy collected based on aspect and slope. Higher solar radiation is expected to correspond with higher SBS.
	OSAVI	The optimized soil adjusted vegetation index is useful for identifying sparse vegetation cover within diverse soil types. Since SBS is derived spectrally, OSAVI was included to explain a degree of variation in SBS that is an artifact.
		Thermal Infrared data collected by the USDA Forest Service National Infrared Operations (NIROPS) Unit was used to identify objects that ignited during the Tubbs Fire. When

Masks	Thermal Infrared	validating the modeled fire behavior to the soil burn severity, it is important to only include ignited objects in our analysis. Only pixels that intersected within a 11.61 foot buffer (3.54 meter) (half the diagonal length of one pixel) buffer of thermal infrared recordings were included in the analysis.
	Impervious Surfaces	In this modeling effort, impervious surfaces include roads, buildings, and water bodies. The land covers were dis-included from the analysis. There are not adequate fuel models for buildings, and no observable soil under buildings, so they are not validated. Roads are spectrally similar to severely burned land cover, and roads would not yield a soil burn severity. Similarly, water bodies should not have an associated soil burn severity. Only the fire behavior of vegetated land cover is included as observations.
Weather	Temperature	Observed temperature data were input to FlamMap for modeling fire intensity for the Tubbs Fire. One thousand hours of temperature data were collected from the Petaluma, California weather station from Weather Underground. Temperature affected the output metric via fuel conditioning.
	Relative Humidity	Observed relative humidity data were input to FlamMap for modeling fire intensity for the Tubbs Fire. One thousand hours of humidity data were collected from the Petaluma, California weather station from Weather Underground. Relative humidity affected the output metric via fuel conditioning.
	Wind	Wind speeds for simulating fire intensity were held constant at 30 miles per hour (48.3kmh).

Multinomial Logit Regression

The validation resembles expectations for a confirmatory analysis of the fire intensity metric. Variation in SBS is highly random variable, depending not only on fire intensity, topography, and soil moisture, but also in microclimate conditions during the fire, soil exposure to flames, and spectral variation in the sampled image processed as SBS. Despite this challenge, the analysis teased out statistically significant predicting effects of nearly all dependent variables on SBS. Moreover, all statistically significant coefficients have the expected association with the probability of a given level of SBS compared to the probability of “Low” SBS.

The coefficients for fire intensity, for example, shows that a 1% increase in the metric are associated with a -0.105 change in the log-odds of “None” SBS as compared to “Low” SBS. In other words, an increase in fire intensity is more likely associated with “Low” SBS than it is “None” SBS. Similarly, a 1% increase in fire intensity is more likely associated with “Moderate” SBS than with “Low”. This change in odds is even more pronounced when comparing the association of “High” SBS to “Low”.

This pattern is elicited in nearly all other variables. There are no real expectations for the outcome of OSAVI, but the distinct pattern indicates spectral artefacts from the calculation of

SBS do affect the dataset. Higher elevation is associated with higher soil burn severity, possibly because soil is generally dryer at higher elevation. Steeper slope indicates greater likelihood of higher SBS, though this association is not statistically significant for the comparison of “High” SBS to “Low” as it is “Moderate” to “Low” and “None” to “Low”. Solar Radiation shows this pattern for the two statistically significant coefficients, but deviates from the expected pattern for the non-statistically significant “High” coefficient.

Soil types are binary variables that reflect the change in log-odds of a given SBS as compared to the “Low” SBS. Wet soil and Rock Land soil are consistent with expectations, since these soils correspond to a greater likelihood of lower SBS. A null value is shown in Soil Type 4, Silty Clay Loam, due to too few observations coinciding with “Moderate” SBS.

Table D 23: Results of Multinomial Logit Regression for SBS on predictor variables

Multinomial Logistic Regression “Low” SBS is the base outcome Coefficients represent the change in log-odds for a one unit increase in the variable. Coefficients compare “None”, “Moderate”, and “High” SBS, respectively, to “Low” SBS 23,412 Observations				
Log likelihood = -19,302.317 McFadden's Psuedo-R ² = 0.1641 Likelihood Ratio Chi-sq (42) = 7,576.63 Prob > Chi-sq = 0.000***				
Variable	Coefficients	Standard Error	Z-Score	P-Value
(Constant)	5.109***	0.639	7.992	0.000
	-1.741***	0.604	-2.882	0.004
	20.758***	2.218	-9.360	0.000
Log Fire Intensity	-0.105***	0.021	-4.994	0.000
	0.123***	0.021	5.746	0.000
	0.300***	0.063	4.776	0.000
OSAVI	-.203***	0.071	-17.041	0.000
	1.432***	0.087	16.529	0.000
	3.518***	0.379	9.274	0.000
Log Slope	-0.347***	0.039	-8.915	0.000
	0.580***	0.059	9.841	0.000
	0.736	0.246	2.992	0.286
Log Elevation	-0.581***	0.070	-8.299	0.000
	-0.203***	0.079	-2.563	0.010
	1.923***	0.275	6.980	0.000
Log Solar Radiation	-0.166***	0.011	-14.450	0.000
	0.051***	0.014	3.698	0.000
	-0.049	0.046	-1.067	0.286

Soil type 1 (Loam)	1.700***	0.392	4.334	0.000
	-3.272***	0.120	27.370	0.000
	-4.455***	0.324	-13.731	0.000
Soil type 2 (Rocky Loam)	1.680***	0.424	3.961	0.000
	-0.290	0.158	-1.833	0.067
	-29.024***	0.000	-5.909e+13	0.000
Soil type 3 (Silt Loam)	2.289***	0.399	5.738	0.000
	-1.623***	0.143	-11.366	0.000
	-20.388***	0.000	-1.250e+09	0.000
Soil type 4 (Silty Clay Loam)	2.565***	0.648	3.959	0.000
	-32.904	NaN	NaN	NaN
	-10.540***	0.000	-1.933e+06	0.000
Soil type 5 (Clay Loam)	1.6158***	0.399	4.052	0.000
	-0.436***	0.126	-3.464	0.001
	-1.403***	0.324	-4.327	0.000
Soil type 6 (Clay)	-13.457***	0.000	-1.947e+07	0.000
	-11.409***	0.000	-4.837e+06	0.000
	-2.954***	0.001	-4.528e+03	0.000
Soil type 7 (Rocky Clay Loam)	1.254***	0.412	3.042	0.002
	-0.088	0.135	-0.648	0.517
	0.966***	0.289	3.339	0.001
Soil type 8 (Rock land)	1.463***	0.401	3.648	0.000
	-2.453***	0.147	-1.665	0.000
	-18.042***	0.000	-4.609e+07	0.000
Soil type 9 (Wet)	1.403***	0.411	3.412	0.001
	-2.836***	0.194	-14.580	0.000
	-22.729***	0.000	-1.164e+10	0.000
Statistical Significance, *p<0.05, **p<0.01, ***p<.001				

Overall, the validation confirms fire intensity holds the expected relationship with the different levels of SBS, which is the purpose of this analysis. In place of validation using observed fire intensity data from a wildfire, this analysis supports the use of this data to inform stakeholder decision-making regarding wildfire.

D.3.10 Future Research: High Resolution Wildfire Behavior Modeling

D.3.10.1 Infrastructure-specific hazard metrics

In an ideal case, hazards would be defined by specific vulnerabilities of an asset. However, the hazard metrics used in wildfire behavior modeling are originally developed to inform wildfire suppression practices and to prescribe mitigated burns. While these metrics can be applied to assess wildfire severity, the metrics are not direct implications of damage to an asset. Therefore, future research regarding the development of hazard metrics specific to TFS infrastructure could be useful for stakeholders to isolate at-risk locations. For example, at the June 26, 2017 workshop, stakeholders expressed interest in ground heat penetration to assess hazard with respect to subsurface TFS infrastructure. Development of a formula dependent on subsurface depth, soil type and moisture, and surface fire behavior and residency time would directly imply damage to subsurface infrastructure. Of course, the physical properties of the subsurface TFS infrastructure would have to be well known with regard to cracking and thermal fatigue in the heat affected zone.

D.3.10.2 Object Based Wildfire Behavior and Fuel Models

Following an assessment of specific vulnerabilities and corresponding wildfire hazards, stakeholders should conduct prescriptive mitigation to limit wildfire threat. Object-based image analysis (5m or smaller) offers promise for accurate fuel classification, but the representative fuel models lag behind the image analysis techniques. In the near future we would like to see the development of object-based fuel models. This would likely be achieved by combining FARSITE and FlamMap to create a vector-based basic fire behavior module.

Beyond application to mitigation, landscapes would more precisely represent reality as object-based vectors. Limitations to implementation are not computational, rather it is a limit of the fuel models used to represent surface fuels. Fuel models were developed to represent large patches of heterogeneous land cover, hence our resampling of imagery from one meter to five meters. The development of fuel models that represent homogenous ground objects would improve model precision, model applicability, and potentially model accuracy.

D.3.10.3 Data Collection for Data Fusion

Discrepancy between imagery and LiDAR collection dates is a source of error in classification. For example, consider a tree canopy expanding over a paved surface over two years between the collection of LiDAR and imagery. If imagery were collected two years earlier than LiDAR, accurate classification would identify an impervious surface from imagery, and tree height for LiDAR, leading to misclassification as a building. If LiDAR data were collected two years before imagery, accurate classification would identify the zero height of a paved ground, with spectral characteristics of vegetation, and output a misclassification as grass. Similar error could arise for any area that underwent land cover change between collection of imagery and LiDAR data. By using an object-based workflow that ascribed median height to segmented imagery, this error is limited in our analysis, but similar error could arise for any area that underwent land cover change during the time between imagery and LiDAR collection. Frequent and regular collection of airborne LiDAR would limit this error by enabling models to make practical use of the temporal frequency of imagery collection. Alternatively, a data collection program that simultaneously collects spectral and elevation data could eliminate this error for future work.

D.3.10.4 Vegetation succession models for estimating future change in wildfire behavior

In order to model future conditions of wildfire behavior, our model uses future estimates of climate to condition live and dead fuel moistures. However, the model fails to account for changes in land cover affecting local wildfire behavior. In order to create a more accurate--or at least more precise--estimate of future wildfire behavior, research should incorporate vegetation succession models that are functions of climate into fuel model projections.

D.4 References

- Agee, J. K. (2002). The fallacy of passive management managing for firesafe forest reserves. *Conservation in Practice* 3.1: 18-26.
- Ager, A. A., Finney, M. A., Kerns, B. K., & Maffei, H. (2007). Modeling wildfire risk to northern spotted owl (*Strix occidentalis caurina*) habitat in Central Oregon, USA. *Forest Ecology and Management*, 246(1), 45-56.
- Ager, A. A., Vaillant, N.M., & Finney, M.A. (2010). A comparison of landscape fuel treatment strategies to mitigate wildland fire risk in the urban interface and preserve old forest structure. *Forest Ecology and Management* 259.8: 1556-1570.
- Albini, F. A. (1979). *Spot fire distance from burning trees: a predictive model*. Ogden, Utah: Intermountain Forest and Range Experiment Station, Forest Service, U.S. Dept. of Agriculture. Retrieved from <https://catalog.hathitrust.org/Record/007421892>
- Andersen, H.-E., McGaughey, R. J., & Reutebuch, S. E. (2005). Estimating forest canopy fuel parameters using LIDAR data. *Remote Sensing of Environment*, 94(4), 441-449.
- Anderson, H. E. (1982). *Aids to determining fuel models for estimating fire behavior* (No. Gen. Tech. Rep. INT-122.) (p. 22). Ogden, UT: U.S. Department of Agriculture, Forest Service, Intermountain Forest and Range Experiment Station.
- Andrews, P. L., & Rothermel, R. C. (1982). *Charts for interpreting wildland fire behavior characteristics*. Gen. Tech. Rep. INT-131. Ogden, UT: U.S. Department of Agriculture, Forest Service, Intermountain Forest and Range Experiment Station. 21 P, 131. <https://doi.org/10.2737/INT-GTR-131>
- Brinkmann, W. A. R. (1971). WHAT IS A FOEHN? *Weather*, 26(6), 230-240. <https://doi.org/10.1002/j.1477-8696.1971.tb04200.x>
- Burgan, R. E., Andrews, P. L., Bradshaw, L. S., Chase, C. H., Hartford, R. A., & Latham, D. J. (1997). Current status of the Wildland Fire Assessment System (WFAS). *Fire Management Notes*.
- California Department of Forestry and Fire Protection Fire and Resource Assessment Program. (2003). *Changing California: Forest and range 2003 assessment*. Sacramento, California. Retrieved from <http://frap.fire.ca.gov/assessment/index>
- California Department of Forestry and Fire Protection Fire and Resource Assessment Program. (2010). *California's Forests and Rangelands: 2010 Assessment*. Sacramento, California. Retrieved from <http://frap.fire.ca.gov/assessment/index>
- California Department of Forestry and Fire Protection Fire and Resource Assessment Program. (2015). *FRAP Vegetation (FVEG15_1)*. Retrieved from http://frap.fire.ca.gov/data/statewide/FGDC_metadata/fveg15_1.xml
- Cheney, N. P., Gould, J. S., & Catchpole, W. R. (1993). The influence of fuel, weather and fire shape variables on fire-spread in grasslands. *International Journal of Wildland Fire* 3.1: 31-44.

- Cleland, D. T., Freeouf, J. A., Nowacki, G. J., Carpenter, C. A., & McNab, W. H. (2007). Description of ecological subregions: sections of the conterminous United States.
- Collins, B. M., Miller, J. D., Thode, A. E., Kelly, M., Wagtendonk, J. W. van, & Stephens, S. L. (2009). Interactions Among Wildland Fires in a Long-Established Sierra Nevada Natural Fire Area. *Ecosystems*, 12(1), 114–128. <https://doi.org/10.1007/s10021-008-9211-7>
- Collins, B. M., Stephens, S. L., Roller, G. B., & Battles, J. J. (2011). Simulating Fire and Forest Dynamics for a Landscape Fuel Treatment Project in the Sierra Nevada. *Forest Science*. Retrieved from <http://agris.fao.org/agris-search/search.do?recordID=US201600098524>
- Dillon, G. K. (2015). Wildfire Hazard Potential (WHP) for the conterminous United States (270-m GRID) (Version 2014 continuous). Fort Collins, CO: Forest Service Research Data Archive. Retrieved from <https://doi.org/10.2737/RDS-2015-0047>
- Dillon, G. K., Menakis, J., & Fay, F. (2015). Wildland Fire Potential: A Tool for Assessing Wildfire Risk and Fuels Management Needs. Retrieved November 26, 2017, from https://www.fs.fed.us/rm/pubs/rmrs_p073/rmrs_p073_060_076.pdf
- ESRI. (2017). ArcGIS Pro (Version 1.4). Redlands, CA: Environmental Systems Research Institute.
- Fernandes, P. M. & Botelho, H.S.. A review of prescribed burning effectiveness in fire hazard reduction. *International Journal of wildland fire* 12.2 (2003): 117-128.
- Finney, M. A. (2006). An overview of FlamMap fire modeling capabilities.
- Jin, S., Yang, L., Danielson, P., Homer, C., Fry, J., & Xian, G. (2013). A comprehensive change detection method for updating the National Land Cover Database to circa 2011. *Remote Sensing of Environment*, 132, 159–175.
- Keeley, J. (2004). Impact of antecedent climate on fire regimes in coastal California. *International Journal of Wildfire*, 13, 173–182.
- Lewis, S. A., Wu, J. Q., & Robichaud, P. R. (2006). Assessing burn severity and comparing soil water repellency, Hayman Fire, Colorado. *Hydrological Processes*, 20(1), 1–16.
- McDaniel, J. (2013). *Mastication Fuel Treatments in the Southwest*. Northern Arizona University, School of Forestry: Southwest Fire Science Consortium. Retrieved from http://swfireconsortium.org/wp-content/uploads/2013/01/mastication_final.pdf
- National Academies of Sciences, Engineering, and Medicine. (2016). *Attribution of Extreme Weather Events in the Context of Climate Change*. Washington, D.C.: National Academies Press. <https://doi.org/10.17226/21852>
- Pierce, D. W., & Cayan, D. R. (2015). Downscaling humidity with Localized Constructed Analogs (LOCA) over the conterminous United States. *Climate Dynamics*, 47(1–2), 411–431. <https://doi.org/10.1007/s00382-015-2845-1>
- Pierce, D. W., Cayan, D. R., & Thrasher, B. L. (2014). Statistical Downscaling Using Localized Constructed Analogs (LOCA). *Journal of Hydrometeorology*, 15(6), 2558–2585. <https://doi.org/10.1175/JHM-D-14-0082.1>

- Potts, J. B., Marino, E., & Stephens, S.L. (2010). Chaparral shrub recovery after fuel reduction: a comparison of prescribed fire and mastication techniques. *Plant Ecology* 210.2: 303-315.
- Rothermel, R. C. (1972). A mathematical model for predicting fire spread in wildland fuels. Retrieved from <http://www.treesearch.fs.fed.us/pubs/download/32533.pdf>
- Scott, J. H., & Burgan, R. E. (2005). *Standard fire behavior fuel models: a comprehensive set for use with Rothermel's surface fire spread model*. Gen. Tech. Rep. RMRS-GTR-153. Fort Collins, CO: U.S. Department of Agriculture, Forest Service, Rocky Mountain Research Station. 72 P., 153. <https://doi.org/10.2737/RMRS-GTR-153>
- Short, K. C. (2017). *Spatial wildfire occurrence data for the United States, 1992-2015* [FPA_FOD_20170508] (No. 4th Edition). Fort Collins, CO: Forest Service Research Data Archive. Retrieved from <https://www.fs.usda.gov/rds/archive/Product/RDS-2013-0009.4/>
- Sleeter, B. M., Wilson, T. S., Sharygin, E., & Sherba, J. T. (2017). Future Scenarios of Land Change Based on Empirical Data and Demographic Trends: LAND USE PROJECTIONS FOR CALIFORNIA. *Earth's Future*. <https://doi.org/10.1002/2017EF000560>
- State Board of Forestry and Fire Protection. (2016). 2010 Strategic Fire Plan for California [Revised April 2016]. Retrieved from http://bof.fire.ca.gov/hot_topics_resources/fireplanrevison_final_04_06_16.pdf
- Stephens, S. L., et al. (2009). Fire treatment effects on vegetation structure, fuels, and potential fire severity in western US forests. *Ecological Applications* 19.2: 305-320.
- Stephens, S.L., Collins, B. M., Fettig, C. J., Finney, M. A., Hoffman, C. M., Knapp, E. E., North, M. P., Safford, H., and Wayman, R. B. (2018). Drought, Tree Mortality, and Wildfire in Forests Adapted to Frequent Fire. *BioScience*.
- Westerling, A. L. (forthcoming). Wildfire Scenario Projections in California's Fourth Climate Change Assessment. 4th Assessment report or white paper.

D.5 Appendix D Acronyms

BAER	Burned Area Emergency Response
BARC	Burned Area Reflectance Classification
BCSD	Biased Corrected Statistical Downscaling
BFB	Basic Fire Behavior simulation module of FlamMap.
BTU	British Thermal Unit
CAIFMG	California Interagency Fuel Mapping Group
CalFIRE FRAP or FRAP	CalFIRE's Fire Resource and Assessment Program
CFP	California Fire Plan
CHM	Canopy Height Models
DEM	Digital Elevation Models
DSM	Digital Surface Models
EDA	Exploratory Data Analysis
ESRI	Environmental Systems Research Institute
FARSITE	A vector-based simulation software for estimates of wildfire spread.
FBFM	Fire Behavior Fuel Model
FlamMap	A pixel-based wildfire simulation software.
FPA FOD	Fire Program Analysis Fire-Occurrence Database
FRCC	Fire Regime and Rotation Class product created by the LANDFIRE program
GCM	Global Climate Model or General Circulation Model
GNDVI	Green Normalized Difference Vegetation Index
GPS	Global Positioning System
HFRC	Historical Fire Rotation Class product created by CalFIRE FRAP
las	LiDAR data exchange file
LiDAR	Light Detection and Ranging
LOCA	Localized Constructed Analog model
LULCcond	Land Use Land Cover conditions present under specific population growth scenario modeled by Sleeter et al (cite)
MEV	Mean Estimated Values of area burned by wildfire for each GCM+PRCP+LULCcond modeled by Westerling, A. L. (forthcoming)
MTBS	Monitoring Trends in Burn Severity
MWTR	Modeled Wildfire Threat Rankings
NAIP	National Agriculture Imagery Program

NDVI	Normalized Difference Vegetation Index
NDWI	Normalized Difference Water Index
NFDRS	National Fire-Danger Rating System
NIR	Near-Infrared
NLCD	National Land Cover Dataset
NSF	National Science Foundation
OBIA	Object-Based Image Analysis
OSAVI	Optimized-Soil Adjusted Vegetation Index
PFB	Potential Fire Behavior product created by CalFIRE FRAP
RAVG	Rapid Assessment of Vegetation Condition after Wildfire
RCP	Representative Concentration Pathways
SBS	Soil Burn Severity
SMS	Segment Mean Shift algorithm
SVM	Support Vector Machine
TFS	Transportation Fuel Sector
USDA	United States Department of Agriculture
USGS	United States Geological Survey
VCC	Vertical Canopy Cover
VIC	Variable Infiltration Capacity model
WFLC	Wildfire Leadership Council
WHP	Wildfire Hazard Potential
WTI	Wildfire Threat Index product created by CalFIRE FRAP

APPENDIX E: Transportation Fuel Sector Stakeholder Data Collection Methods

E.1 Introduction

This section covers the TFS stakeholder engagement process and the iterative discussion sessions that led to a better understanding of how our models could inform exposure of the TFS to flooding and wildfire. Stakeholder engagement is recognized as a necessary resource for environmental management and policymaking (Freeman, 1984; Organisation for Economic Co-operation and Development, 2004). Nevertheless, the term stakeholder engagement or stakeholder analysis has been used in many ways through with greater or lesser methodological rigor. There is considerable literature on methods for stakeholder analysis that generally defines it as a process to identify individuals, groups, and organizations who are affected or can affect the societal decision-making processes of a studied problem (Reed et al., 2009). A full stakeholder analysis of the TFS goes beyond the scope of this project. The process described here is a pilot effort that helps delineate areas for further investigation into possible consequences of wildfire and flooding for the transportation energy industry business models, stakeholders, and regulation.

Our stakeholder engagement process is designed with two general goals: a) identify when and where the TFS individual assets, its interconnected physical network, and its organizational network are most vulnerable to wildfire and flooding; and b) identify how this vulnerability could drive changes to the TFS regulatory framework.

E.2 Stakeholder Engagement Process: Population Sampling and Milestones of Data Collection

We define stakeholders as groups of private and public organizations in the transportation fuel sector that affect or are affected by proactive and reactive decisions regarding abrupt or incremental threats from flooding and wildfire. As explained in Chapter 4, our stakeholders are divided into TFS Core, TFS Dependent, and TFS Knowledgeable, which represent the organizational units of analysis.

Three engagement mechanisms allow us to interact with the stakeholder population: the technical advisory committee, area/regional workshops, and stakeholder discussions. The Technical Advisory Committee (TAC), consists of representatives of industry stakeholders that own and operate key TFS assets (labeled *TFS core*), representatives of organizations that provide services on which the TFS core organizations rely heavily (labeled *TFS dependent*), and representatives of groups that regulate and or research TFS core organizations (labeled *TFS Knowledgeable*). We present preliminary plans and results to this TAC to ensure that the study is highly informed and includes as many types of stakeholders and assets as possible. The TAC serves as the starting point for identifying organizations to invite to the workshops and discussions (**Figure E 1**).

We organize the workshops to collect information from the public and from the TFS stakeholders to improve our understanding of the assets in the TFS network, its internal and external interdependencies, and the stakeholders' areas of concern from an extreme weather-related event perspective. In addition to these workshops, we hold discussions with various

groups of TFS stakeholders to gain detailed insights into their TFS assets, potential vulnerabilities to extreme weather events, interdependencies within the sector and with other sectors, potential strategic plans already in place or being developed, etc.

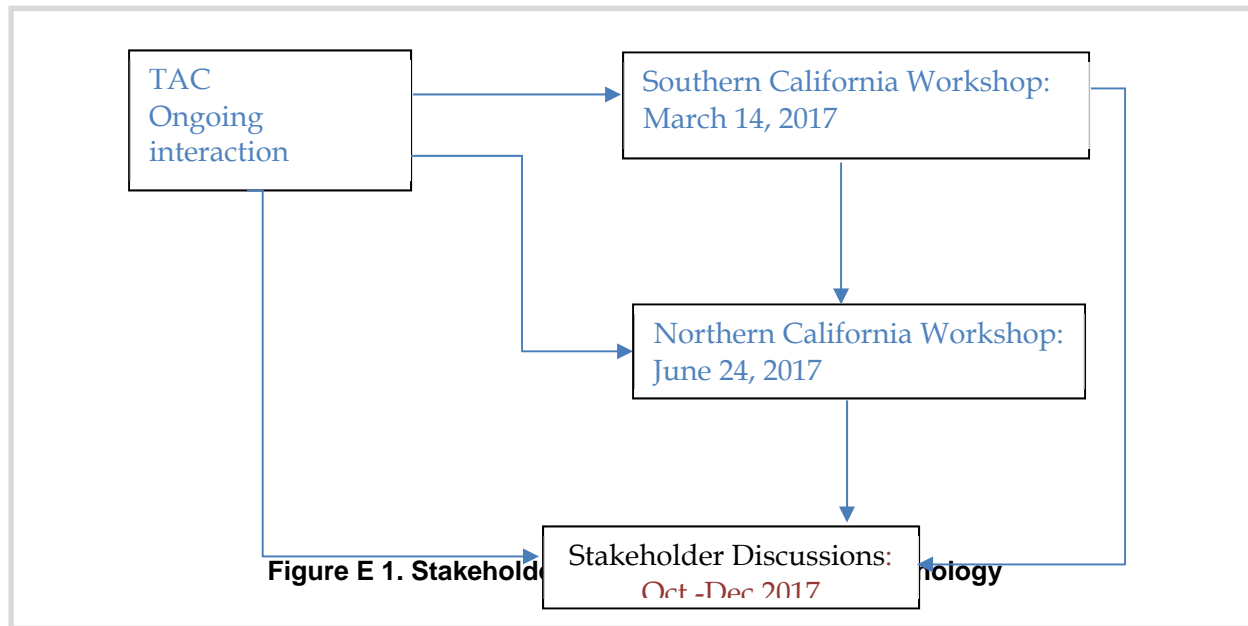

Interaction with stakeholders is the premise to making sense of the results of our flood and wildfire exposure modeling since exposure of the TFS assets to wildfire or flooding does not necessarily translate to asset damage. The stakeholder engagement process depended on how well we could communicate our projected wildfire and flooding scenarios and consequently, how well our stakeholders understood and relied on our models. Therefore, the continuous engagement process was designed to promote an iterative interaction with our stakeholders. The Northern and Southern California workshops provided the initial forums to disseminate exposure models to the stakeholders.

As a common method of qualitative research, our stakeholder engagement process fits a purposive and snowball sampling technique. Unlike probability sampling, the purposive sampling technique allows us to select units of analysis that are strategic for answering our research questions. The snowball sampling technique starts with a small group of organizations that are relevant to our research question (i.e. the TAC). The TAC proposed new organizations or other individuals within their organizations who could help answer the research questions and this cycle continues. Snowball sampling can be viewed as a form of convenient sampling, but it is often used to cover populations that are hard to access because they are not well defined (Byman, 2016). This scenario fits our research and the TFS, not only because of the fuzzy boundaries of this complex sector, but also because the nature of this business is highly competitive, publicly stigmatized, and thus closed to any unofficial stakeholder engagement processes.

One of the strategies behind our sampling process was to target a variety of owners and operators of the key assets in the TFS, identified in **Figure E 2**. We included stakeholders that

the TFS Core organizations are dependent on, as well as stakeholders that regulate and research TFS Core organizations. Stakeholder heterogeneity adds value to risk management in technological and organizational innovation (Hall, Bachor, & Matos, 2014), especially when their interests and functions are diverse (i.e. the nature of their responsibilities and relationship vis-a-vis the TFS). This heterogeneity also allowed us to gather information on specific oil and transportation assets even if we did not reach their owners or operators. This expansion also conforms with the snowball sampling design, as one of the results from our engagements with the Core organizations was the referral to Dependent and Knowledgeable organizations.

To understand the representativeness of the stakeholders we engaged with, we also categorized them based on their TFS knowledge pool. This categorization was important to connect the nature of the stakeholder’s expertise to our TFS model (**Figure E 2**).

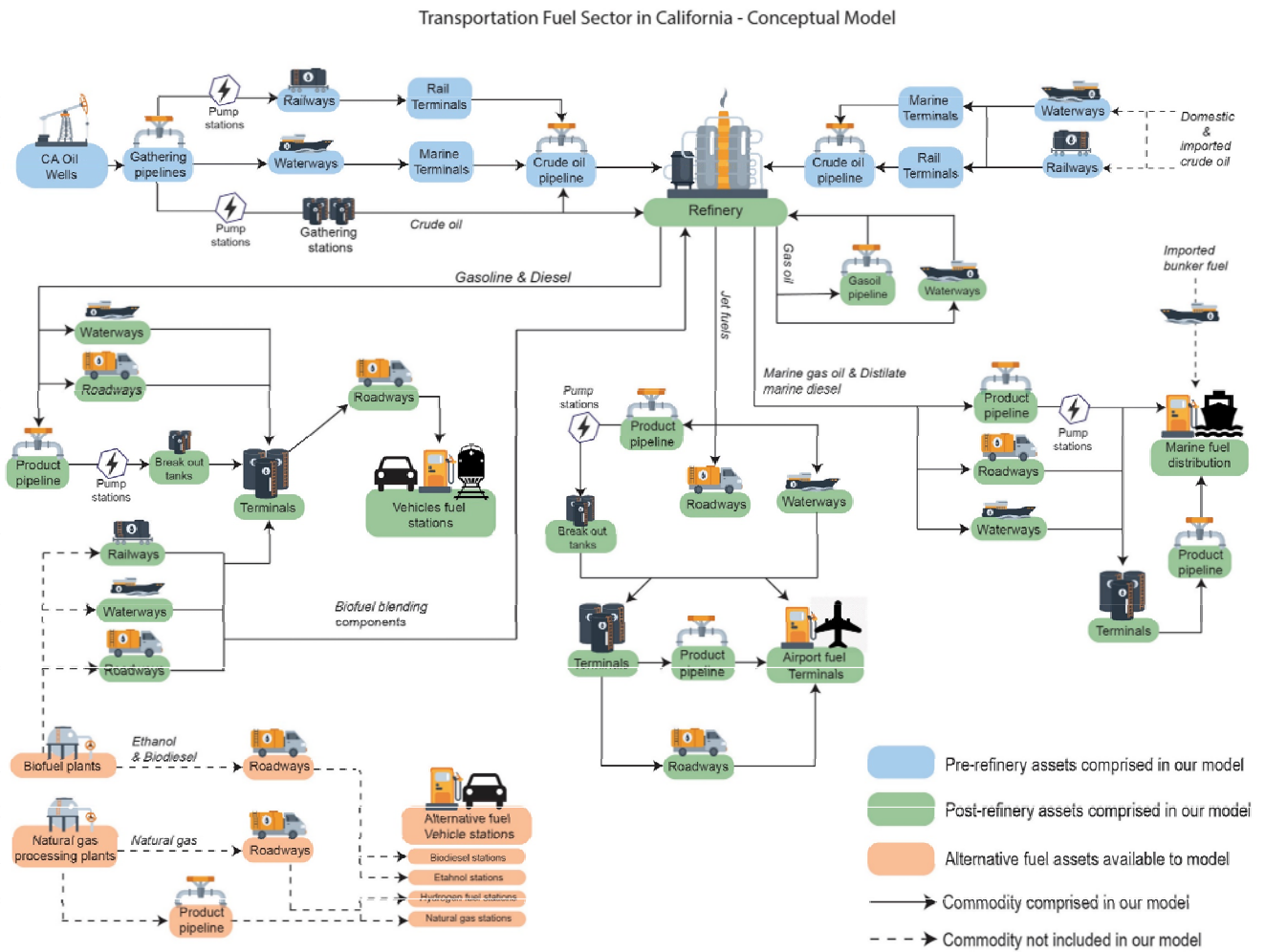

Figure E 2. Core stakeholders: TFS key oil and transportation assets

This categorization illustrated that many of our stakeholders hold valuable experience and information on TFS assets and industry business segments that are not necessarily attached to their current job position within an organization (**Table E 1**).

Table E 1. TFS Stakeholder Knowledge Pools

<p><u>Commodity subsystem</u></p> <ul style="list-style-type: none">• Crude oil• Refining (includes all products + gasoil)• Motor vehicle fuels (gasoline, diesel, biofuels, LPG)• Jet fuels (kerosene, naphtha)• Marine fuels (marine gasoil, distillate marine diesel, residual oil) <p><u>Key oil infrastructures (nodes)</u></p> <ul style="list-style-type: none">• Oil fields/gathering stations• Marine terminals/wharfs• Crude rail terminals• Refineries• Distribution terminals/ Bulk plants/ Breakout tanks• Motor vehicle fuel dispensing facilities• Airport fuel dispensing facilities• Marine fuel dispensing facilities <p><u>Key transportation infrastructures (edges)</u></p> <ul style="list-style-type: none">• Pipelines• Railway• Roadway• Waterway <p><u>Dependent infrastructure/ service</u></p> <ul style="list-style-type: none">• Water• Power• Emergency management

E.2.1 Stakeholder Engagement Process: Data and Documents

We used stakeholder-specific memos, maps, and tables as supporting documents for our stakeholder outreach initiatives. We presented data on estimated past, present, and future exposure of assets to support discussion with stakeholders regarding the vulnerability of exposed assets. Data and documents used to support engagement are described in the following subsections.

E.2.1.1 Supporting Wildfire Documents

A memo describing the wildfire hazard metrics, as well as maps of historical wildfires, present threats, and predicted changes to exposures in the future, were generated to provide the stakeholders with insight into wildfire threats, as they are relevant to their assets.

The purpose of the memo was to describe wildfire hazard metrics and to highlight the importance of providing information on instances of damages using historical wildfire maps and tables. The TFS stakeholders expressed a need for damage metrics that describe the potential impact of a wildfire on a terminal, refinery, pipeline, rail, or trucking corridor. However, our modeling metrics estimated potential wildfire, defined as hazard or potential exposure, without speculating on potential impact as a function of vulnerability of an asset. Understanding possible impact patterns of the wildfire behavior metrics on the TFS is one of the goals of the stakeholder engagement process, although correlations of fire risk and expected loss is far from being fully understood in post-fire effect research (Hardy 2005).

Historical Wildfires near Stakeholder Assets

Maps displaying historical wildfire perimeters that intersected or fell within a buffer distance of stakeholder assets were provided in stakeholder engagements. The maps were provided with associated tables that listed the indexed wildfires on the map, event date, and the wildfire acreage burned. The data was provided so stakeholders could identify any wildfires that intersected their assets and caused physical damage or disrupted the flow of product. An instance of damage could highlight a potential vulnerability of the asset to wildfire in the future. We would then use the high-resolution wildfire model to simulate wildfire behavior using pre-incident historical imagery and thereby estimate the combination of fire behavior and asset structure that would yield damage.

The historical wildfires were collected from CALFIRE FRAP fire perimeter data, version 16_1. Wildfires within a buffer distance of a stakeholder's assets and within a date range were included. The buffer distance depended on the asset type. For pipeline assets, a 0.8-km (0.5-mile) buffer was used to account for potential damage from direct fire exposure or from excavation strikes. For trucking and rail routes, wildfires within a larger 1.6-km (1-mile) buffer were included to account for potential flow disruption from smoke plumes that would presumably not affect pipeline operations.

The range of years included in the query depended on the stakeholder history and the availability of pre-incident data. Wildfires were included in the maps if they occurred while the stakeholder owned the asset. However, since the LANDFIRE data used to model pre-incident conditions began in 2001, this is the earliest date of wildfires included in the analysis. If a wildfire was of interest (defined as one that caused damage and occurred after 2008), National Agriculture Imagery Program (NAIP) – the primary imagery input to high-resolution wildfire behavior modeling – was used for modeling. If wildfire damage was reported between 2001 and 2007, wildfire behavior was estimated at 30-m (horizontal) resolution using the LANDFIRE.

Current Wildfire Threat to Stakeholder Assets

Current wildfire threat to assets was represented by intersecting the CALFIRE FRAP Threat Map (2017) with each stakeholder's infrastructure. A half-mile buffer was used to show the threats nearest to stakeholder assets. The raster Threat dataset is at 30-meter horizontal resolution and is a function of likelihood of wildfire and the potential wildfire severity.

Likelihood is defined as fire rotation, or the time-step between historical wildfires in a given area. Potential wildfire hazard is represented in the dataset as fuel rank, which is a function of topography and land cover type.

Estimated Changes in Future Wildfire Exposure

In addition to historical instances of wildfires near assets and current estimated threat to assets, the data used for Wildfire Projections (See Appendix E, Section 2) were summarized into thirteen intersection maps. Five maps showed the estimate of threat for double-decadal periods between 2000 and 2099. Four maps showed the change in wildfire threat such that 2000-2019 was used as a baseline, and one map showed the change in threat between the baseline and each subsequent double-decadal period. Four additional maps were created to display the change in risk between each period (i.e. the difference between threat in 2000-2019 and 2020-2039, the difference between 2020-2039 and 2040-2059, and so on). The threat for each double-decadal period was created using data produced by Leroy Westerling for the Fourth Assessment. For each GCM, RCP, and population projection, the median projection of projected area burned per year was presented for each double-decadal period (See Appendix D Section 2).

Medians were used to represent conservative estimates to stakeholders. Similar to current wildfire threat maps, future wildfire projections were included to elicit stakeholders' perceptions of future wildfire risk, changes in future wildfire risk, and to inspire interest in targeted high-resolution wildfire behavior hazard modeling.

E.2.1.2 Supporting Flood Documents

To summarize inland and coastal flooding projections (See Appendix C) relevant to individual stakeholder assets, flooding exposure projection maps were created for seemingly vulnerable study sites. The flood maps were produced by simulations using the median sea-level rise, storm, and rainfall scenario to represent a conservative estimate of potential exposure, similar to the wildfire projection maps. Two maps for each potentially vulnerable study site were generated, one for the median scenario in 2040 and one for the median scenario in 2100. The goal of stakeholder engagement using these maps was to solicit information about any assets that could be inundated, specifically if and how the exposed assets would be vulnerable to damage from inundation.

E.3 Discussion Formats and Goals

After the initial interactions with stakeholders, more specific research topics were defined:

- 1) Understand the TFS as a critical interconnected infrastructure with physical and organizational networks.
- 2) Link the measured outputs of hazard models to damage propensity of the stakeholder's exposed assets and supply and demand chain network.
- 3) Identify these stakeholder's strategic planning for weather related hazards in the context of climate change.

These goals guide the stakeholder discussions. The information provided by the stakeholders depends highly on the understanding of our modeled wildfire and flooding scenarios. Since not

all of the stakeholders that attended the discussions participated in our exposure modeling descriptions during workshops, visuals or even full presentations by the wildfire and/or flood modeling teams were sometimes necessary. As a result, there are three types of discussion formats (**Table E 2**).

Table E 2. Discussion Formats

A	IN-DEPTH STAKEHOLDER DISCUSSIONS
AB	IN-DEPTH STAKEHOLDER DISCUSSIONS WITH HAZARD MODEL VISUAL SUPPORT
B	PRESENTATION OF WILDFIRE AND FLOODING MODELS FOLLOWED BY SHORT DISCUSSION

We conduct 21 discussions in the A-AB-B format covering 18 different organizations: 13 Core, 4 Knowledgeable, and 1 Dependent³. A number of topics were raised during the discussions, organized in a manner similar to semi-structured interviews. The variety of stakeholders and the exploratory nature of this procedure demand a great deal of flexibility in how the discussions were set up. The goal was to steer the discussions so that the stakeholders could explain how they frame the modeled hazard scenarios presented to them.

E.4 Discussion Guide Description

Our stakeholder discussions require map-elicitation, as some of the questions are grounded using our modeled hazards in maps of flooding and wildfire scenarios. These maps help anchor questions about linking the outputs of our hazard models to the expectation of damage to the stakeholder’s asset portfolio. Due to this heavy emphasis on map-elicitation, the preparation for the actual discussion involves personalization of the model results to organization-specific asset types and supply chain networks.

Vignette-type questions were also a major component of our discussions as they are very useful to realistically elicit reactions to certain scenarios (Bryman, 2016). By describing an event or scenario in words, stakeholders’ strategic planning for specific climate change threats were addressed.

E.4.1 Guide Narrative

The TFS was globally defined in this project as the physical, organizational, and institutional factors that enable the supply and distribution of transportation fuel in California. This conception consists not only of physical elements (assets) and material designs, but also includes organizational framework for management, control, and institutional systems that constraint and support the operation of these assets. This definition leads to a specific investigation process and design that are intended to follow the potential impact propagation of

³ Asides from the numerous informal meetings and interactions with the TAC members that helped us outline the discussion procedures and goals, we also conducted three piloting discussions beforehand, one for each Stakeholder category that are not included in this count.

the exposure to wildfire and flooding from physical components (A and B) to more abstract dimensions of the TFS (C and D) (Figure E 3).

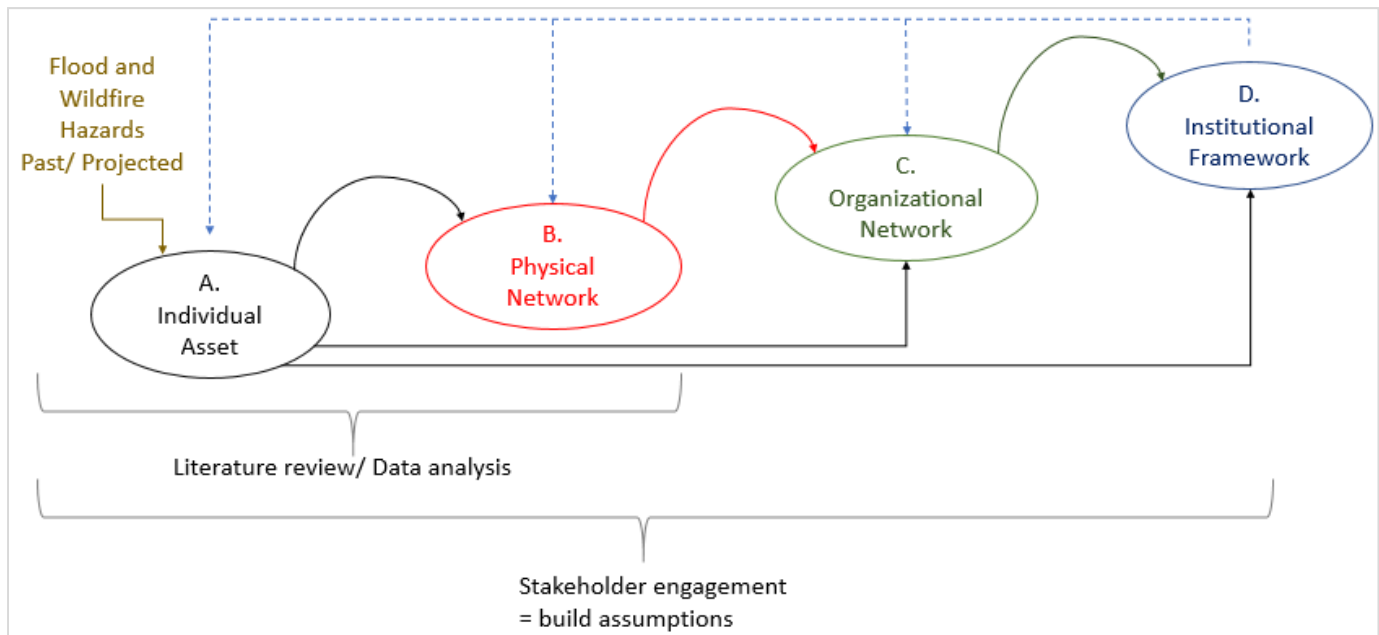

Figure E 3. Approach to understanding the different vulnerabilities of the TFS to modeled hazards

The dimensions can be further described as:

- | | |
|-----------------------------|--|
| A. Individual Assets: | Physical units of the infrastructures that form the TFS. If we are looking at pipelines for example, these assets can relate to microscale assets such as specific joints; mesoscale assets such as valves or pumps and macroscale assets such as specific buildings like breakout tanks or offices. |
| B. Physical Network: | The systemic infrastructural view of the TFS, where all assets are functionally linked from fuel flow perspective. |
| C. Organizational network: | The inter- and intra-organizational relations that are formed to reliably operate and manage transportation fuel supply and distribution. |
| D. Institutional framework: | The systems of formal laws, regulations, procedures, and informal conventions, customs, and norms, that shape socioeconomic activity and behavior within the TFS organizations. |

The discussions' introductory questions are designed as a warm up, usually covering information we should be able to convey before the meeting. The introductory section is also important for us to identify the knowledge pools of the stakeholders.

The next step is to present projected wildfire and flooding scenarios overlaid with organization-specific TFS asset information (please see **Figure E 4** and **Figure E 5** as examples). This is also done with historic wildfire burn perimeters overlaid with the stakeholders' assets. This exercise sets the stage for the next three topics that rely on map-elicitation for driving the conversation and grounding the stakeholders' answers.

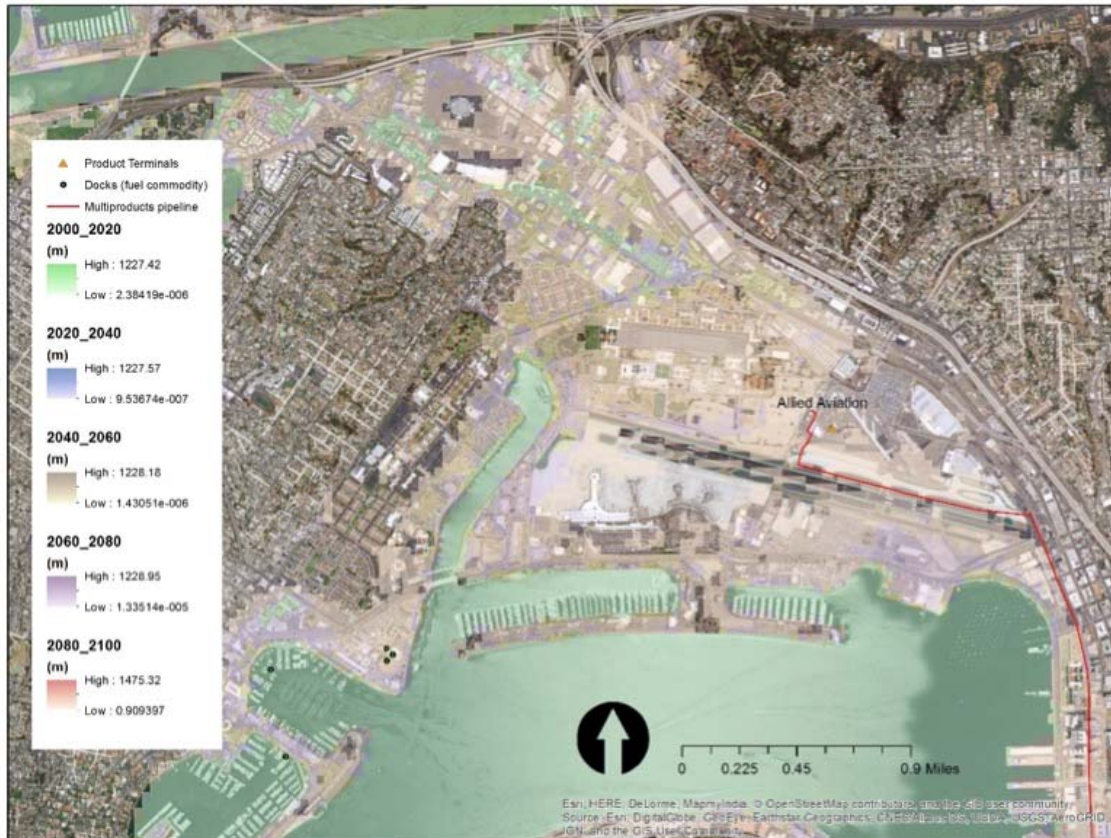

Figure E 4. Example of map-elicitation on flooding scenario used during discussion

The first set of map-oriented questions (dimension A) have the objective to understand how our modeled hazards results could help identify damage propensity to the individual assets that are directly exposed.

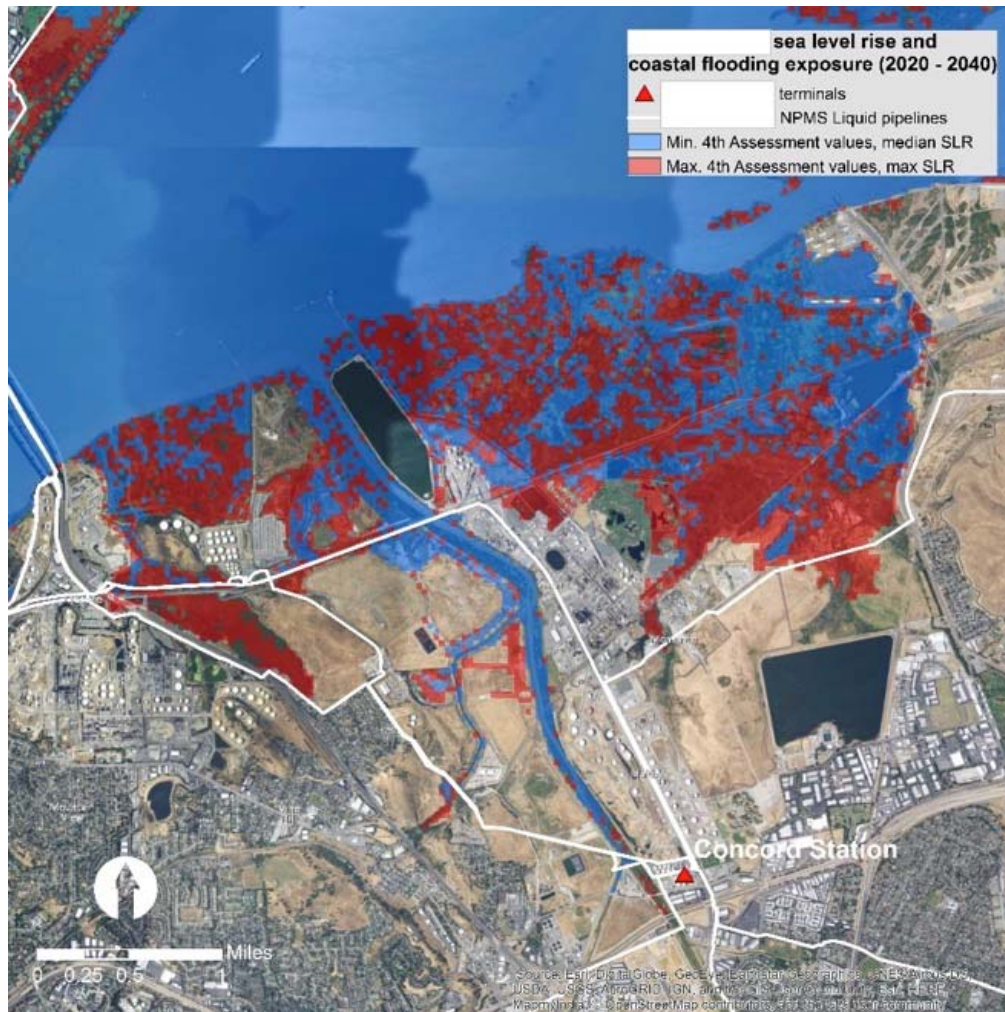

Figure E 5. Example on map-elicitation for flooding scenario used in discussion

In this section, we also connect metric hazard outputs to damage propensity. Our aim is to assess if these assets have any unique operating thresholds or sensitivities that can either be measured through rate of spread, fire line intensity, or flame length for wildfire hazard, or measured through depth and duration for flooding hazards.

Questions 8 to 13 of the discussion guide (part E.8) are designed to understand how the damage to individual assets could have an indirect effect on interconnected assets (dimension B). This also involves understanding the perceived direct impact to assets that are not operated by the stakeholder but are connected to their assets in the supply and demand chain. These questions help assess the interconnectedness of certain organizations but also, by cross-comparison of different discussion results, this indicated the awareness of the interdependency between “neighbors”.

Questions 14 to 16 were developed to understand how the possible damages identified through the previous questions would affect the inter-organizational structure in an emergency and recovery situation.

Questions 17 to 19 intend to uncover how the possible damages discussed above have induced any changes in internal procedures or strategic planning, or if the organizations see any need for change in the current institutional framework that regulates their operation from a critical infrastructure point of view.

The last section is designed to elicit discussion around our research questions in the advent that the scenarios presented were not successful (questions 20 to 24).

In general, our introductory, first-, and second-block questions addressed the initial research question for understanding and describing the TFS; the second- and third-block questions addressed our second research question making sense of the exposure models, while third-, fourth-, and concluding blocks revolved around answering our third research question on strategic planning.

It was difficult to find one stakeholder we were able to elicit discussions to the full spectrum of topics designed. The topics addressed usually demand the participation of multiple individuals in the same organization.

E.5 Challenges of the Applied Process and Lessons Learned

Since the methods discussed above were applied to a heterogeneous group, there were a number of challenges experienced during the application of the stakeholder engagement process.

Stakeholder Specific Vocabulary

Depending on the stakeholders involved in the discussions, a simple shift from the word “organization” to the word “company” or “firm” or vice versa would make a difference in the quality of our discussion.

Not all organizations within the TFS use the same name or label for specific assets. This led to confusion on which asset stakeholders were actually referring to. For example, a “terminal” is defined by some organizations as any multi-modal transloading point. For others, it is a transloading point regardless of mode or it just represents a storage point with no transloading at all. This was problematic as the terminals represent a key oil infrastructure that we have as a unique layer in our models. Since the discrepancy was noted after a number of discussions, it impacted the characterization of TFS connectivity in our maps.

Reaching Full-breadth of Stakeholders

a. Individuals Do Not Fully Represent an Organization

A person representing an organization during a discussion is also an individual with his or her own belief system. Another challenge that arises is identifying in each organization which job position or professional background of the individual would be the most appropriate to help us answer our research questions or even link us to the person that would do so. This gets increasingly complicated when there was no one single person that could address the range of questions we developed, which was often the case. Controlling for specific job positions of the stakeholders was attempted in an overarching way, although this is almost contradictory to snowballing sampling technique.

b. Lack of resources to reach all levels within an organization

To properly answer our third question on strategic planning, we aimed for the highest levels of decision makers from the TFS Core and TFS Dependent stakeholders. However, our sample was small. We also did not include shareholders of these companies in our sample.

Since the scope of the project focused on Californian territory only, there were logistical and financial limitations if an interesting stakeholder organization had its headquarters in another state. Moreover, even if there is a clear identification of the job titles and professional background we are profiling, this would not necessarily translate to the exertion of influence that is perceived by a certain professional position. It is not uncommon to misrepresent the role of a person in an organization (Harvey, 2011).

E.6 Conclusion

The stakeholder engagement process revealed itself as a useful tool for better understanding the TFS and reciprocally provided insight for the organizations to understand the risks associated with climate change, specifically flooding and wildfire. Communicating climate change science for pragmatic decision-making is complex because of the weight of uncertainties. Developing a dialogue about climate change with industries that are stigmatized as major causes of this problem adds a layer of complexity to this process. Our iterative engagement procedure coupled with organization-personified high-resolution modeling results for wildfire and flooding seemed to have raised fruitful engagement with some specific companies as is developed in Chapter 4 of this report.

Finally, the non-probability nature of the sampling method applied here does not qualify our results for generalization to the TFS organizations. Although it is important to underscore that the complexity of the TFS organizational network, the heterogeneity of stakeholders, and the nature of this industry make generalizations of stakeholders very difficult from a quantitative perspective. A proposition for further developing this specific portion of the project would be to apply the lessons learned from this exploratory stakeholder engagement process, which includes using a set of questions and language for specific stakeholder profiles and expanding the sampling method to have significant coverage of our TFS Core, Dependent, and Knowledgeable population.

E.7 References

- Byman, A. (2016). *Social Research Methods*. Oxford, UK: Oxford University Press.
- Freeman, R. E. (1984). *Strategic Management: A Stakeholder Approach*. New York: Basic Books.
- Hall, J., Bachor, V., & Matos, S. (2014). The impact of stakeholder heterogeneity on risk perceptions in technological innovation. *Technovation*, 34(8), 410–419.
<https://doi.org/10.1016/j.technovation.2013.12.002>
- Organisation for Economic Co-operation and Development. (2004). *Stakeholder Involvement Techniques: Short Guide and Annotated Bibliography* (No. NEA No. 5418). Retrieved from <https://www.oecd-nea.org/rwm/reports/2004/nea5418-stakeholder.pdf>
- Reed, M. S., Graves, A., Dandy, N., Posthumus, H., Hubacek, K., Morris, J., ... Stringer, L. C. (2009). Who's in and why? A typology of stakeholder analysis methods for natural resource management. *Journal of Environmental Management*, 90(5), 1933–1949.
<https://doi.org/10.1016/j.jenvman.2009.01.001>

E.8 Discussion Guide

Introductory Topics:

1. *Where does the organization fit in our conceptual TFS model?*
2. *What products does the organization work with and in what way? (i.e. crude oil, gasoline, diesel, jet fuel, etc.)*
3. *Has the organization had any wildfire or flooding incidents?*

I. Topics associated with damage to **individual assets** (i.e. depth damage curves).

4. *What specific infrastructure is the organization worried about in relation to wildfire and flooding exposure?*

This might relate to:

- “microscale” assets such as specific joints;
- “mesoscale” assets such as valves or pumps;
- “macroscale” assets such as specific building/tank or office, i.e. Control Rooms
- “system” assets such as entire pipeline systems

5. *When considering wildfire and flooding, what information is more valuable to the organization to prevent and mitigate adverse events due to exposure? Why?*

- Wildfire hazard metrics: Rate of Spread/ Fireline Intensity (BTU) /Flame length
- Flood hazard metrics: Depth / Duration/ Scouring

6. *If the asset is permanently damaged how difficult, financially and/or time-wise, would it be to replace it?*

II. Topics associated with **damage to network** functionality/ flow of fuel (criticality metrics)

7. *What are the origins and destinations of the products the organization works with in this mapped area?*
8. *How are normal operations defined?*
9. *How would a disruption and failure of operations of the organization be defined? Due to wildfire or flooding?*
10. *Assuming assets that could suffer damage from flooding and wildfire, how would this damage cause disruption of operations? How likely would the damage cause failure of operations?*
11. *In what way(s) would this disruption or failure affect other assets of the organization? Would this affect other organization’s assets?*
12. *If another organization’s asset is permanently damaged, how long would it take to affect the operations of this organization? (If dealing with transport infrastructure type use nearby fixed infrastructure damage scenario or vice versa)*

III. Topics related to **organizational structure** while facing wildfire/flooding

13. *Considering the damage scenario, what position(s) in the organization are responsible for responding to the incident and returning assets to normal operations? What actions would be taken?*
14. *Which external organizations would this organization need to contact or work with in order to recover normal operations? What position at that organization would be responsible and what actions would be taken by that organization?*
15. *Does the organization undertake near or long-term planning with any other interconnected (TFS or not) organizations with regards to wildfire and flooding scenarios? How so, and what organizations/industries does this include?*

IV. Topics related to **institutional framework**

16. *What are the organization's planning horizons?*
17. *What is the organization's level of interest in undertaking near or long-term planning for wildfire and flooding risk with relation its assets?*
18. *How is interaction with TFS industries/organizations enabled or restricted by procedures, licensing & regulation when dealing with wildfire and flooding risk?*

Concluding Topics

19. *What would be a worst-case scenario/ nightmare for the operations of the organization? (not necessarily wildfire or flooding)*
20. *How does the organization plan around this?*
21. *Does planning involve interaction with people within the organization but from other sectors/premises?*
22. *Does this involve interaction with people outside the organization? Which organizations and function? What actions are taken?*
23. *What other organizations in the TFS have dealt with wildfire or flooding events or that engage with strategic planning around these risks?*

APPENDIX F: Vulnerability of Alternative Transportation Fuels to Coastal Flooding and Wildfire in California: Hydrogen Fuel Case Study

F.1 Introduction

Alternatives to legacy petroleum-based liquid fuels such as electricity, compressed natural gas, ethanol, liquified natural gas, propane, biodiesel, and hydrogen only represent less than 6% of current transportation energy demand in California (Lawrence Livermore National Laboratory, 2014). Nevertheless, California is the leading State in the U.S. on investment and development of alternative transportation fuel stations, currently equipped with over 5,500 private and public fuel stations representing more than 10 times the national average (U.S. Department of Energy, 2018). Hydrogen fuel is available in less than 1% of these distribution stations in California, but at a national level, the State is the leading investor in and developer of this alternative fuel type with more than 70% of operational stations in the U.S. California has an eminent role in alternative transportation fuel development and specifically hydrogen fuel, which is reinforced by the high number of incentives and regulations that are specific to the implementation of hydrogen fuel infrastructure.

To take into account this distinct feature of California's TFS, this appendix will present an overview of hydrogen fuel infrastructure in the State, existing and planned hydrogen fueling stations' exposure to wildfire and coastal flooding, and finally the perspectives of hydrogen fuel stakeholders regarding their industry's vulnerability to near- and long-term wildfire and flooding hazards. This case study is also relevant in the context of growing incentives on climate change mitigation solutions, such as zero-emission vehicles (ZEVs). ZEVs have experienced notable market penetration, overwhelmingly representing plug-in electric vehicles (PEVs) rather than fuel cell electric vehicles (FCEVs). In 2014, the first FCEVs were released for wholesale and retail markets of California with cumulative sales of more than 4,600 vehicles. As hydrogen fuel is a new and growing industry, it has a unique opportunity compared with the existing conventional fuel sector to consider current and projected exposure to extreme weather hazards in the industry's initial investment and incorporate it into the future investment cycles.

F.2 Overview of the Hydrogen fuel's regulations and infrastructure in California.

F.2.1 Hydrogen Fuel Infrastructure Regulation

For almost three decades, the investment in and development of alternative fuels has intended to reinforce the country's transportation energy efficiency and vehicle emissions reduction in the interest of mitigating climate change effects and improving air quality (ZEV Mandate, CARB 1990; Energy Policy Act of 1992, 1992). California has a leading role in incentives and regulations for the entry and increase of alternative fuels in the TFS, with more than one third directly related to hydrogen fuel (U.S. Department of Energy, 2018).

Considering the multiple advantages of ZEVs in achieving climate goals and air quality standards, California Executive Order B-16-2012 was issued as a milestone for alternative fuel incentives that set long-term targets for the number of ZEVs in the State's motor vehicle count and emissions reduction goals. The ZEVs Promotion Plan directed all State agencies, with

emphasis on the California Energy Commission (CEC), the California Public Utilities Commission (CPUC), and the California Air Resources Board (CARB) to facilitate and accelerate the entry of ZEVs into vehicle market, in conjunction with the private sector through the California Fuel Cell Partnership (CFCP). One of the major challenges for the expansion of ZEVs in California is the insufficient number of hydrogen fueling stations for FCEV drivers (Chiladakis, Crowfoot, & Winston, 2013). Therefore, improving the mobility of FCEVs through the proliferation of refueling stations remains critical to the expansion of ZEVs in California (Orenberg, 2018). On January 26th, 2018, the policy was updated to outline new goals for the hydrogen fuel sector in California to include 200 hydrogen fueling stations constructed by 2025 and five million ZEVs on California roads by 2030 (Office of Governor Edmund G. Brown, Jr., 2018)

California has 35 public operational hydrogen fueling stations and 26 public stations currently planned, commissioned, or under construction (U.S. Department of Energy, 2018) for a total of 61 public hydrogen refueling locations (**Figure F 1**). Following the tendency observed with the conventional TFS hubs in Northern and Southern California (Ch.2), most of the stations have been sited in the San Francisco Bay Area and Los Angeles. Other stations are being developed on the highways connecting the two major metropolitan areas in California, as well as the Sacramento Valley to Reno (NV) along the roadways belonging to the National Alternative Fuel Corridors (Turchetta, Purcell, & Nyhan, 2018)

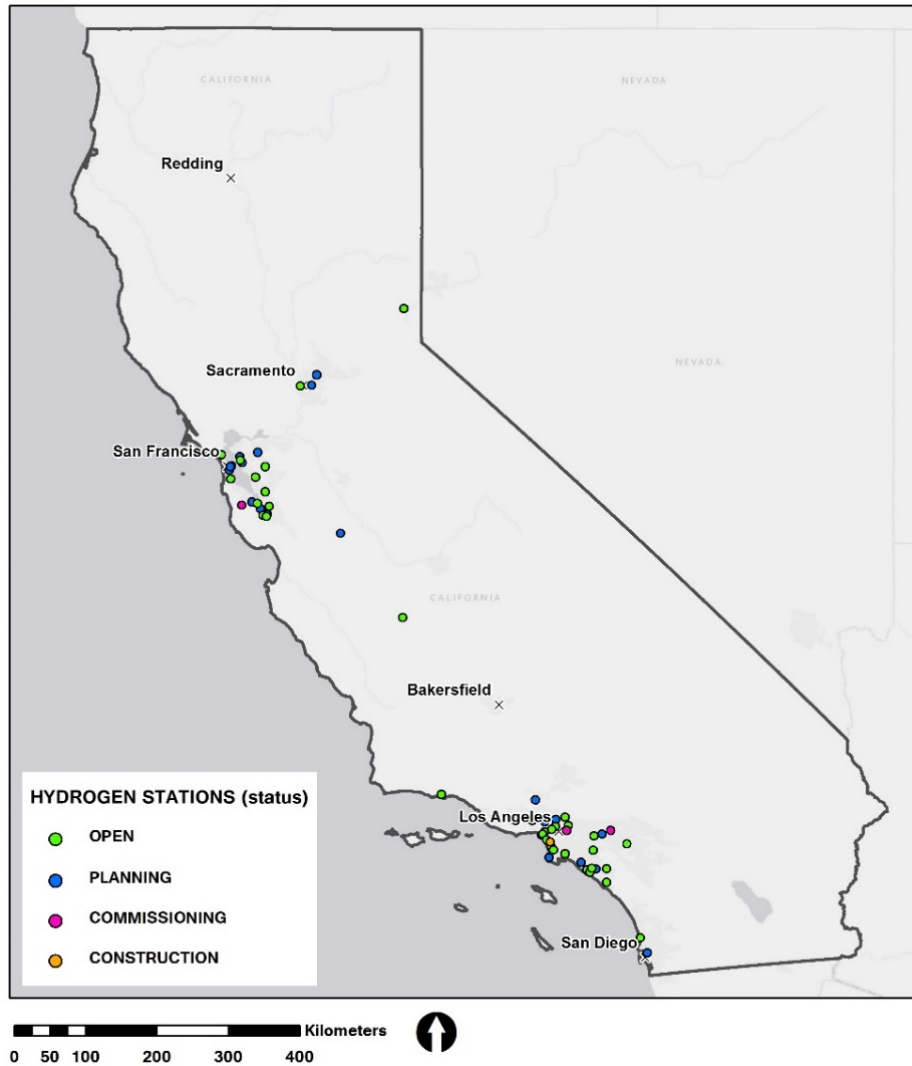

Figure F 1. Current and Planned Hydrogen Fueling Stations in California (Source: (California Fuel Cell Partnership, 2018))

F.2.2 California’s Hydrogen Fuel Supply-Chain

Compared to traditional motor vehicles, one of the advantages of FCEVs is found in the abundance of hydrogen fuel sources. Hydrogen is the most frequently occurring element known in the universe, therefore the main effort in its production as fuel depends upon the separation of hydrogen molecules from molecules where it naturally occurs. In the U.S. hydrogen fuel demand in transportation comes from not only private and government FCEVs, but also from industrial utilitarian fleets (forklifts) and space rockets (U.S. Energy Information Administration, 2018). Other major producers and users of hydrogen are petroleum refineries (CH.2.3) that possess on-site steam reforming of natural gas also known as steam methane reforming (SMR).

The hydrogen industry has a great variety in fuel production methods. Electrolysis is considered as a renewable pathway for hydrogen fuel production based on the splitting of hydrogen molecule from other molecules (most commonly water) with electricity or microbial biomass (Office of Energy Efficiency & Renewable Energy, 2018a). At present, SMR is still the most common method employed to produce bulk hydrogen fuel, and it is responsible for 95% of the US hydrogen fuel production (Office of Energy Efficiency & Renewable Energy, 2018b). According to the CEC's Advanced Vehicle Infrastructure Office Hydrogen Station sourced database (March 2018), this significant proportion is also the case in California with 92% of hydrogen fueling station sources coming from SMR and only 8% from electrolysis.

When compared with conventional fuels, hydrogen has a much simpler supply chain (**Figure F 2**) from production origins (SMR or electrolysis plants) to its final destination in one of the 35 hydrogen fueling stations currently operating in California. An innovative aspect of the hydrogen fuel supply chain is that there are several fully integrated hydrogen fueling stations in California designed to produce hydrogen on-site. Most of on-site production relies on electrolysis production method, but there is one station at the Los Angeles International Airport that has on-site SMR production. Although on-site production technology exists, the volume produced does not suffice the FCEVs' current demand. Therefore, 92% of hydrogen fuel consumed in stations comes from off-site production, including out-of-state sources (CEC-Advanced Vehicle Infrastructure Office data-base, 2018). The transportation from these off-site SMR facilities is primarily executed by truck, even though it is moved via pipeline in some rare cases.

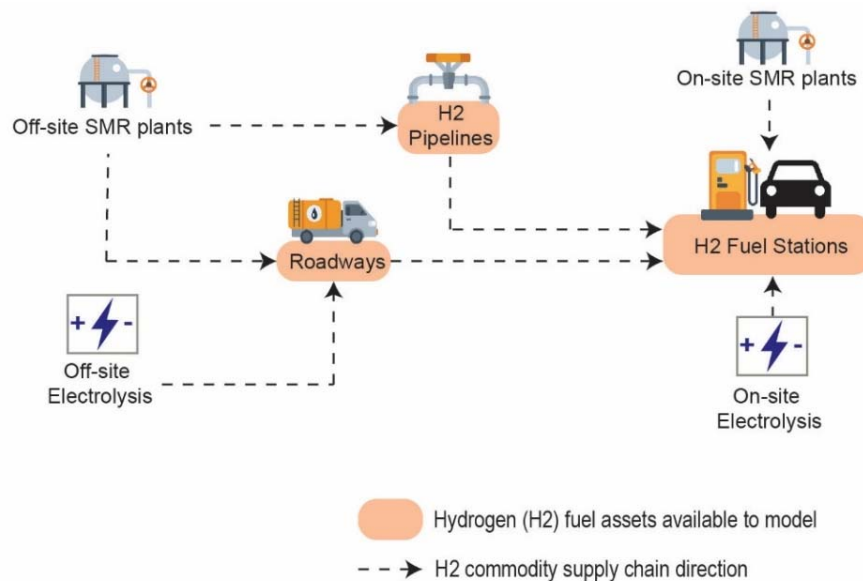

Figure F 2. Hydrogen Fuel Supply Chain

F.3 Statewide Exposure of Hydrogen Fueling Stations in California to Wildfire and Coastal Flooding

F.3.1 Coastal Flooding Statewide Exposure

The statewide exposure assessment of hydrogen fueling stations to coastal flooding is based on projected sea level rise and storm surge at 50 m (164 ft) spatial resolution using 3Di hydrodynamic model (for more information see main body Section 3.2.1. and Appendix C). As modeled for the conventional TFS, the following results represent the median flooding event among the combined RCP 4.5 and RCP 8.5 scenarios. From the 61 stations, only two currently open stations located in the San Francisco Bay Area are exposed to flooding (**Figure F 3**). The Mill Valley station is exposed to flooding starting in the 2000-2020 period, and the South San Francisco (SF) station is exposed starting at 2040-2060 period. **Figure F 4** shows details of the South SF hydrogen station's exposure to coastal flooding according to the high-resolution model (5 m or 16.4 ft) for the 2020-2040 and 2080-2100 periods.

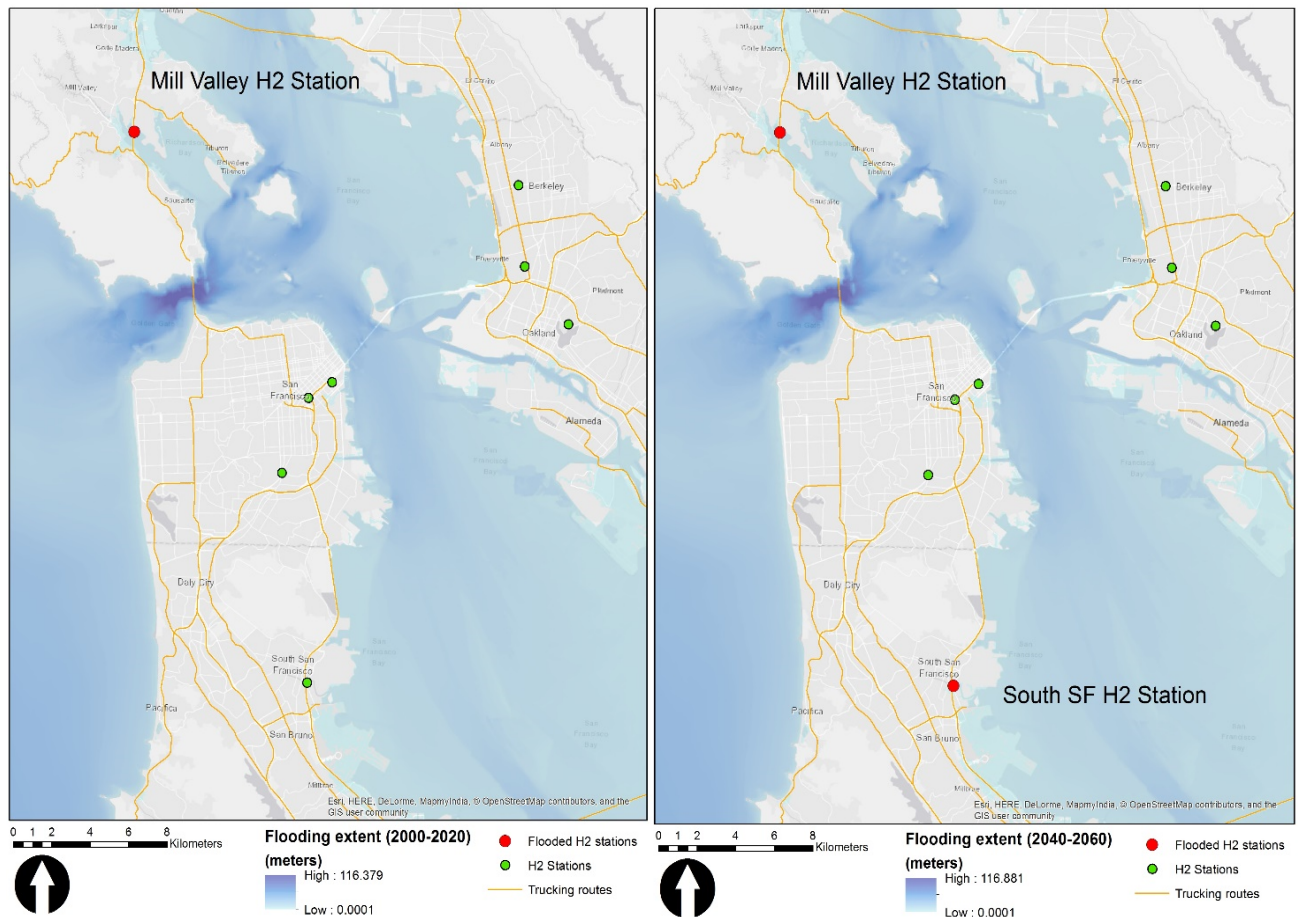

Figure F 3. Coastal flooding exposure of Hydrogen (H2) Fueling Stations in the San Francisco Bay Area (50m resolution)

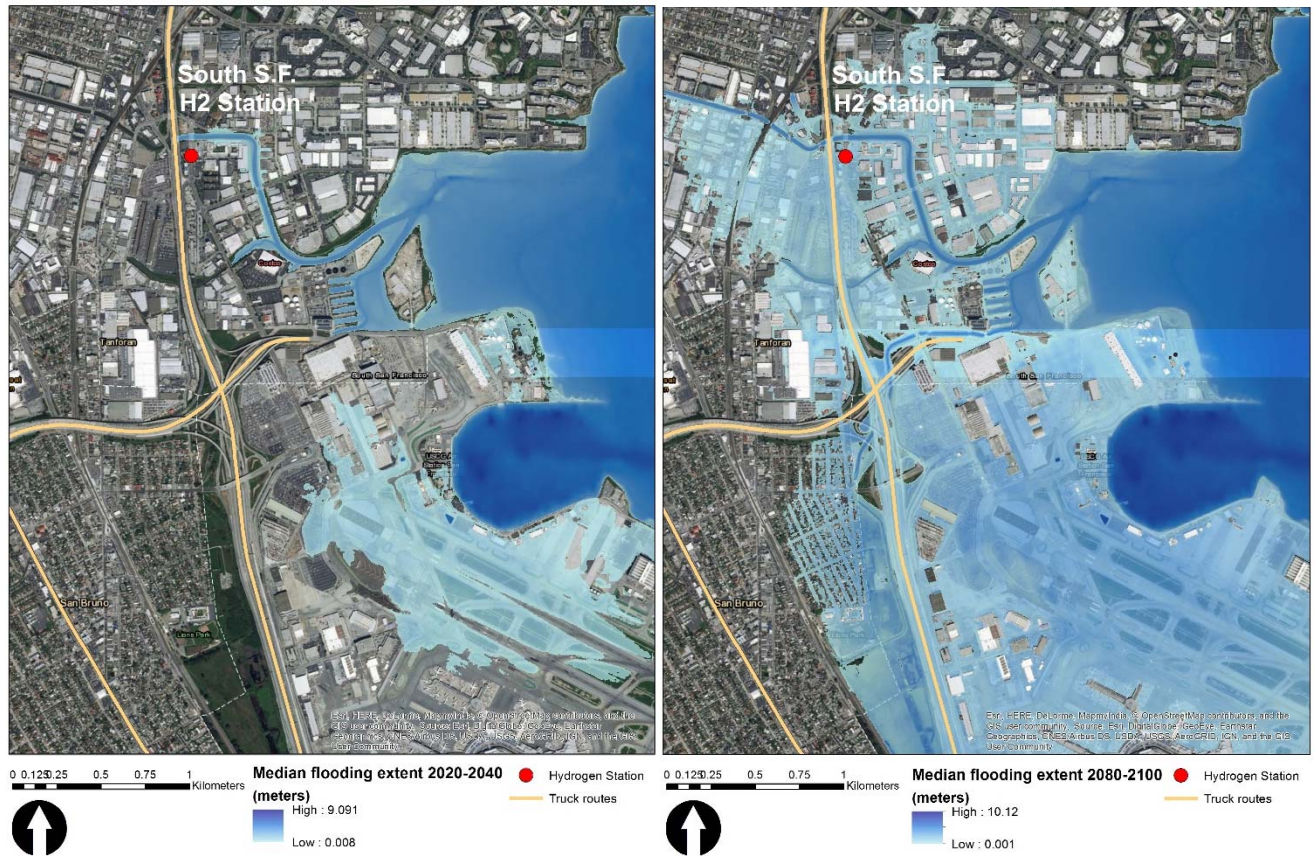

Figure F 4. South S.F. Hydrogen Fueling Station Exposure to Coastal Flooding at High-Resolution (5m) for 2020-2040 and 2080-2100.

F.3.2 Wildfire Statewide Exposure

The exposure of the 61 current and projected hydrogen fueling stations to large wildfires is presented in **Figure F 5** and **Figure F 6**. As modeled for the conventional TFS, this assessment uses the Modeled Wildfire Threat Rating (MWTR) system developed by Westerling (forthcoming). At 6.2 km wildfire forecasting cell resolution (3.8 mi), this method captures the outputs of probabilistic wildfire forecasting. In this section the MWTR system describes the relative threat of large wildfire occurrence throughout the State over five 20-year periods from 2000 to 2100 for the locations of 61 hydrogen stations currently sited. Although our results depict that the total proportion of California's territory with an "Extreme" MTRW classification increases between 2000-2020 and 2080-2100 (See Figure 17 Ch.3.2.2.1.), none of the currently open or planned hydrogen stations fall under this threat class. The majority of hydrogen stations assessed here fall in areas where the exposure to large wildfire is negligible, because they are located in dense urban areas or near large bodies of water. The total number of hydrogen fueling stations that are exposed slightly diminishes throughout the different time-horizons, and only one of the 35 currently open stations becomes exposed to "Very High" MWTR class from 2020 onwards. None of the planned stations that are exposed to wildfire fall under "High" or "Very High" threat rate.

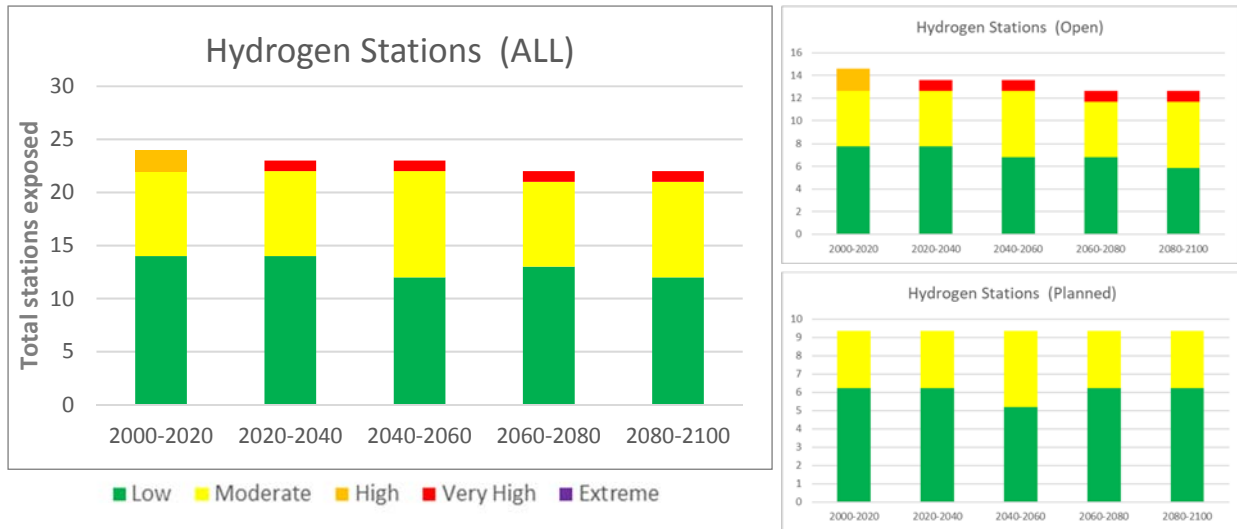

Figure F 5. Total number of Hydrogen Fueling Stations Exposed to Wildfire. Exposure based on Modeled Wildfire Threat Rating – MWTR (see Ch.3.2.2.1).

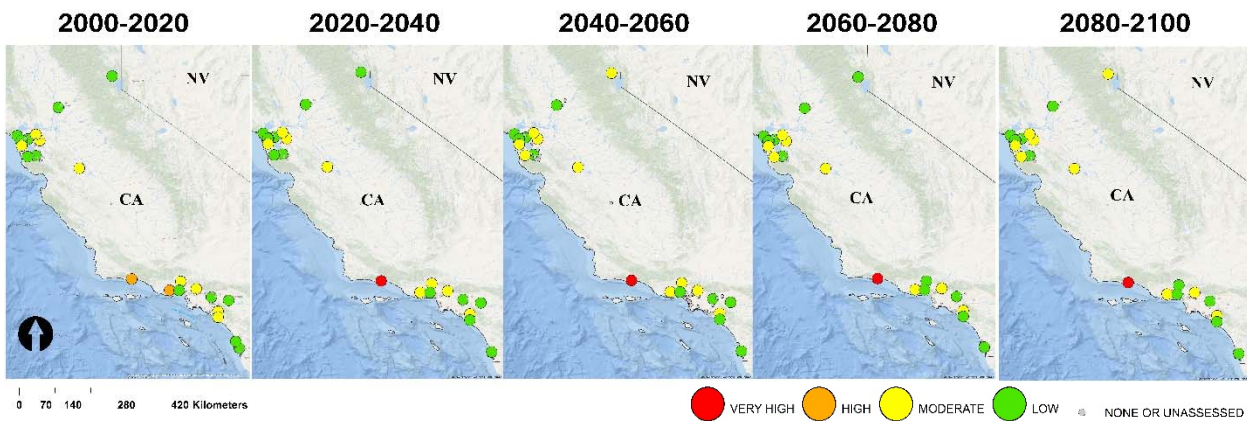

Figure F 6. Location of Hydrogen Fueling Stations Exposed to Wildfire. Exposure based on Modeled Wildfire Threat Rating – MWTR (see Ch.3.2.2.1).

F.4 Hydrogen Fuel Stakeholder Engagement

Discussions were held with hydrogen fuel stakeholder organizations to understand their perspective on wildfire and flooding threats to their industry. These stakeholders were sampled from the California Fuel Cell Partnership list of providers, developers, operators, designers, and State regulators working in the hydrogen fuel sector. From the initial sample of 31 stakeholders, we held discussions with seven private companies and one State regulatory organization. The discussions were framed by three major topics:

- 1) The organization's historical impacts from wildfire and flooding events;

- 2) The organization's asset vulnerability to future wildfire and flooding events;
- 3) The organizations' current or future actions and policies designed to address potential impact from wildfire or flooding.

For topics 1 and 2, the majority of discussions led to very few historical incidents of operational impact from wildfire or flooding. Most organizations stated that their market entry is too recent to have experienced any disruptions from these extreme weather events, or that they are not exposed to one or both hazards. In a few cases, there have been local disruptions with low consequences to the station operations related to the flooding of pumping stations and on-site pipelines. Most stakeholders did mention that disruptions have been reported from wildfires and flooding due to closed roadways that impacted the truck supply of hydrogen fuel to the stations. In discussions around future vulnerability for topic 2, stakeholders indicated very limited damage propensity for the hydrogen fueling stations to flooding and wildfire. Several organizations noted concern over future stations projected for suburban areas with varied topography that constitutes a higher wildfire risk. Throughout the discussions with stakeholders, there were frequent mentions of vulnerability from roadways threatened by wildfires that would potentially disrupt the supply and distribution of hydrogen fuel.

For topic 3, all of the private organizations mentioned that complying with local permitting regulations represents the most common pathway at their level for mitigating extreme weather-related hazards. Some organizations identified policies that require compliance with rainfall-return periods of 50 and 100 years for storm water drainage structures designed to address flooding hazards. The stakeholders reported that there are no regulations to address threats from wildfire.

As mentioned in the beginning of this section, there are many incentives designed to facilitate the development of hydrogen fuel infrastructure. One example described by stakeholders was the CEC's Alternative and Renewable Fuel and Vehicle Technology Program that targets gaps in the development and deployment of alternative fuels through grant programs that scale up to 20 million dollars each year. To help the ZEV industry in the identification of areas with the greatest need for infrastructure development, CARB developed the California Hydrogen Infrastructure Tool (CHIT). The CHIT functions as a GIS planning tool that evaluates the relative need for hydrogen Infrastructure based on gap analysis between projected ZEV demand and current alternative fuel infrastructure (Martinez, 2015). During our stakeholder discussions, the CHIT was referred to as a valuable resource for the hydrogen fuel sector to inform the siting of stations and represents an opportunity for incorporating extreme weather models to make better investment decisions for transportation fuel infrastructure.

F.5 Conclusions

The exposure of California's currently operating or planned hydrogen fueling stations to wildfire and coastal flooding remains low, and only a few stations are sited in prospective flooded areas or areas with high wildfire threat ratings. Nevertheless, it is important to realize that the current supply chain for hydrogen fuel is directly dependent on roadways and truck transportation. It is therefore critical to take into consideration the exposure of roadways to extreme weather hazards--an issue projected to increase throughout the end of this century (see **Figure 14(a)** and **Figure 18** in Ch. 3.2.1.). Concerns with transportation and supply of hydrogen

fuel by trucks was also noted by hydrogen fuel industry stakeholders during our engagement. Another critical part of the supply chain are the sources of hydrogen fuel. Measuring the exposure of SMR and electrolysis hydrogen producing plants that supply to hydrogen fueling stations would be a next step in the vulnerability analysis of the State's hydrogen fuel sector. Finally, current State policy directs the planning and construction of at least 139 additional hydrogen fueling stations in the next seven years, which can benefit from integrating the results of wildfire and coastal flooding exposure models into the industry's siting and decision-making tools such as the CHIT.

F.6 References

- California Fuel Cell Partnership. (2018). *Station Map*. Sacramento, California: Frontier Energy. Retrieved from <https://cafcp.org/stationmap>
- Chiladakis, L., Crowfoot, W., & Winston, R. (2013). California's ZEV Action Plan (pp. 1-6). IEEE. <https://doi.org/10.1109/EVS.2013.6914963>
- Energy Policy Act of 1992, Pub. L. No. H.R. 776, 42 USC 13201 (1992). Retrieved from <https://www.afdc.energy.gov/pdfs/2527.pdf>
- Martinez, A. (2015, October). *California Hydrogen Infrastructure Tool Technical Formulation Webinar: Main Technical Formulation Discussion*. Retrieved from https://www.arb.ca.gov/msprog/zevprog/hydrogen/webinars/chit_technical.pdf
- Office of Energy Efficiency & Renewable Energy. (2018a). Hydrogen Production. Retrieved from <https://www.energy.gov/eere/fuelcells/hydrogen-production>
- Office of Energy Efficiency & Renewable Energy. (2018b). Hydrogen Production: Natural Gas Reforming. Retrieved from web reference: <https://www.energy.gov/eere/fuelcells/hydrogen-production-natural-gas-reforming>
- Office of Governor Edmund G. Brown, Jr. (2018, January 26). Governor Brown Takes Action to Increase Zero-Emission Vehicles, Fund New Climate Investments. Retrieved from <https://www.gov.ca.gov/2018/01/26/governor-brown-takes-action-to-increase-zero-emission-vehicles-fund-new-climate-investments/>
- Orenberg, J. (2018). *2018-2019 Investment Plan Update for the Alternative and Renewable Fuel and Vehicle Technology Program* (No. CEC-600-2017-010-LCF) (p. 96). California Energy Commission, Fuels and Transportation Division.
- Turchetta, D., Purcell, C., & Nyhan, S. (2018). Refueling America. *Public Roads*, 81(4). Retrieved from <https://www.fhwa.dot.gov/publications/publicroads/18winter/02.cfm>
- U.S. Department of Energy. (2018). Alternative Fuels Data Center. Retrieved from <https://www.afdc.energy.gov/fuels/hydrogen.html>
- U.S. Energy Information Administration. (2018). Hydrogen Explained. Retrieved from https://www.eia.gov/energyexplained/index.php?page=hydrogen_production